

EFFICIENCY MASTER TILT TABLE - EM1-500-6050-4

APPROX WEIGHT: 859.35 lbs.
 DOES NOT INCLUDE WEIGHT OF POWER OR PACKAGING!!!

*** ANY ADDITIONS, DELETIONS, OR OMISSIONS MUST BE CORRECTED ON THIS DRAWING AS THIS DRAWING WILL BE CONSIDERED ALL INCLUSIVE ***

ALL GRAPHICS PROVIDED ARE FOR REFERENCE ONLY. IF CERTAIN DIMENSIONS ARE CRITICAL PLEASE VERIFY THOSE DIMENSIONS WITH YOUR SALESPERSON

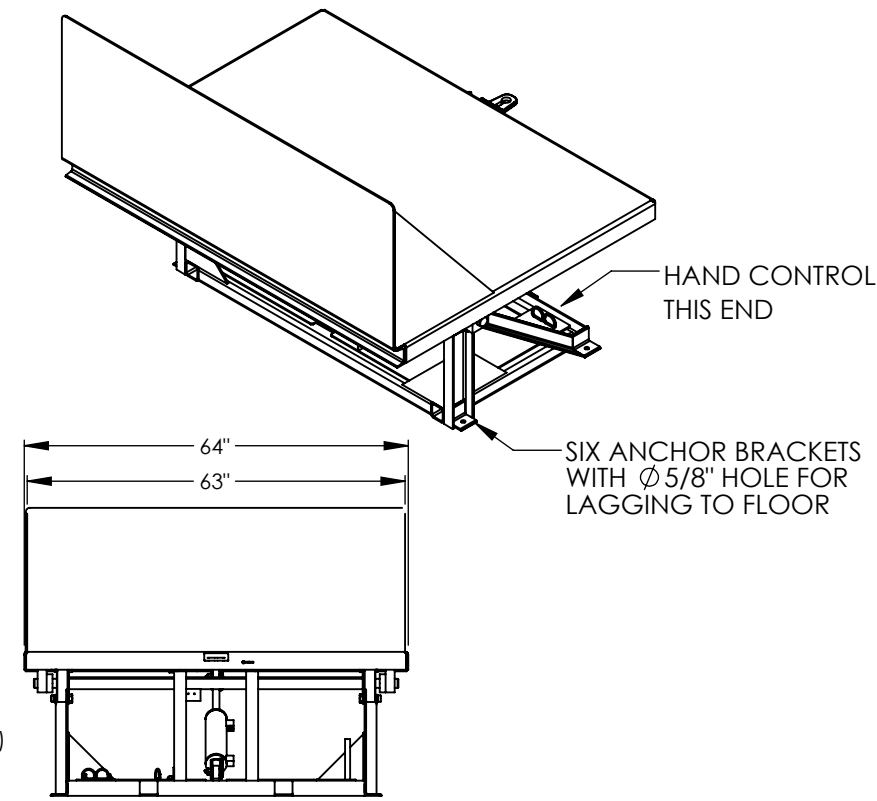
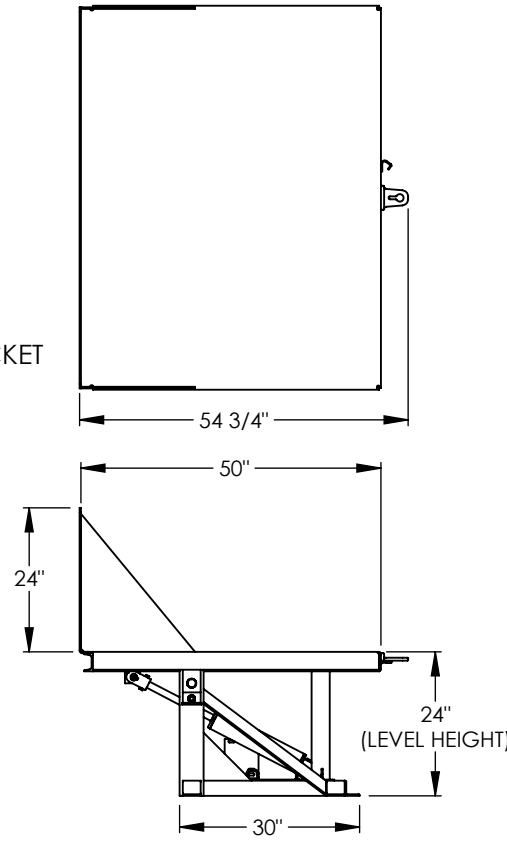
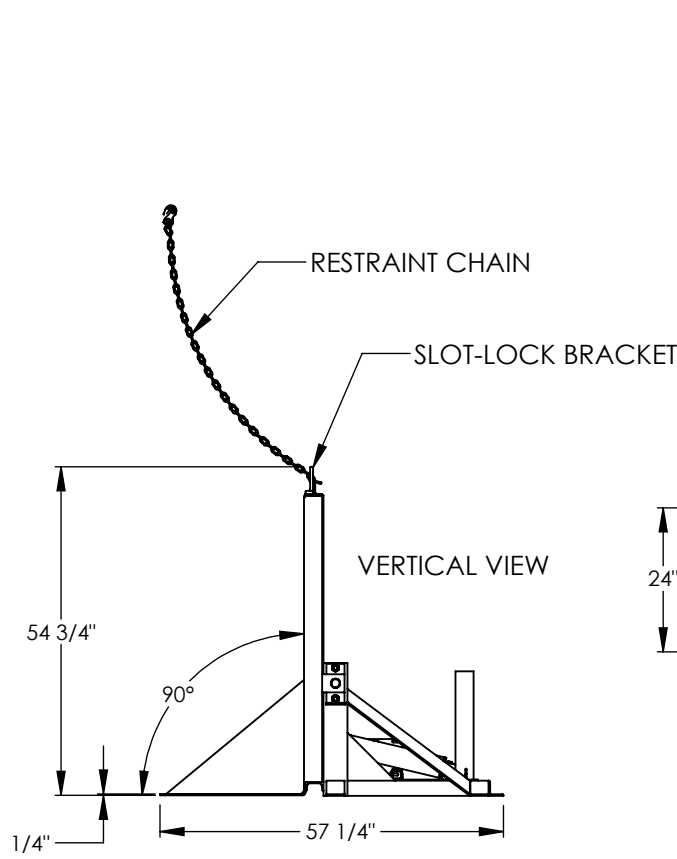

DIMENSION TOLERANCE $\pm 1/4$ "

STANDARD FEATURES

- MODEL NUMBER IS EM1-500-6050-4
- MAX CAPACITY IS 4,000 LBS (EVENLY DISTRIBUTED LOAD)
- USABLE DECK SIZE IS 60" WIDE x 50" LONG
- DECK LEVEL HEIGHT IS 24"
- OVERALL WIDTH IS 64"
- OVERALL LENGTH IS 57 1/4"
- OVERALL HEIGHT IS 54 3/4"
- MAX TILT ANGLE IS 90°
- SAFETY SLOT-LOCK RESTRAINT CHAIN BRACKET
- ALL STEEL CONSTRUCTION
- DURABLE LIQUID PAINT BLUE FINISH
- INTERNAL POWER UNIT
- HANDHELD PUSH BUTTON CONTROL W/8ft EXTENDED COIL CORD
- WARNING: CHECK STATE AND LOCAL CODES

460V 3 PHASE AC POWER

CONTACT FACTORY FOR OTHER POWER OPTIONS

SPECIAL FEATURES

NONE

APPROVAL

I, THE UNDERSIGNED, AGREE THAT THE PRODUCT AS REPRESENTED SATISFIES DESIGN AND DIMENSION REQUIREMENTS. I ALSO ACKNOWLEDGE MY DUTY TO CONFIRM PRODUCT AND INSTALLATION COMPLIANCE WITH ALL APPLICABLE FEDERAL, STATE AND LOCAL REGULATIONS AND STANDARDS.

UNITS REQUIRING APPROVAL DRAWINGS OR MODIFIED ARE NON-RETURNABLE

As drawn As marked

Signed: _____ Date: _____

Printed Name: _____

LEAD TIME WILL START UPON RECEIPT OF SIGNED APPROVAL DRAWING

DISTRIBUTOR'S NAME:		P.O.#
VESTIL MANUFACTURING		X
DRAWN BY: MTS		W.O.#
DATE: 11/17/2015		X
REFERENCE: X	SCALE: 1:32	SALES: X
QUOTED LEAD TIME: X	QUOTE # X	FILE NAME:
		03-007-080