

ELECTRIC ORDER PICKER - EOP-440

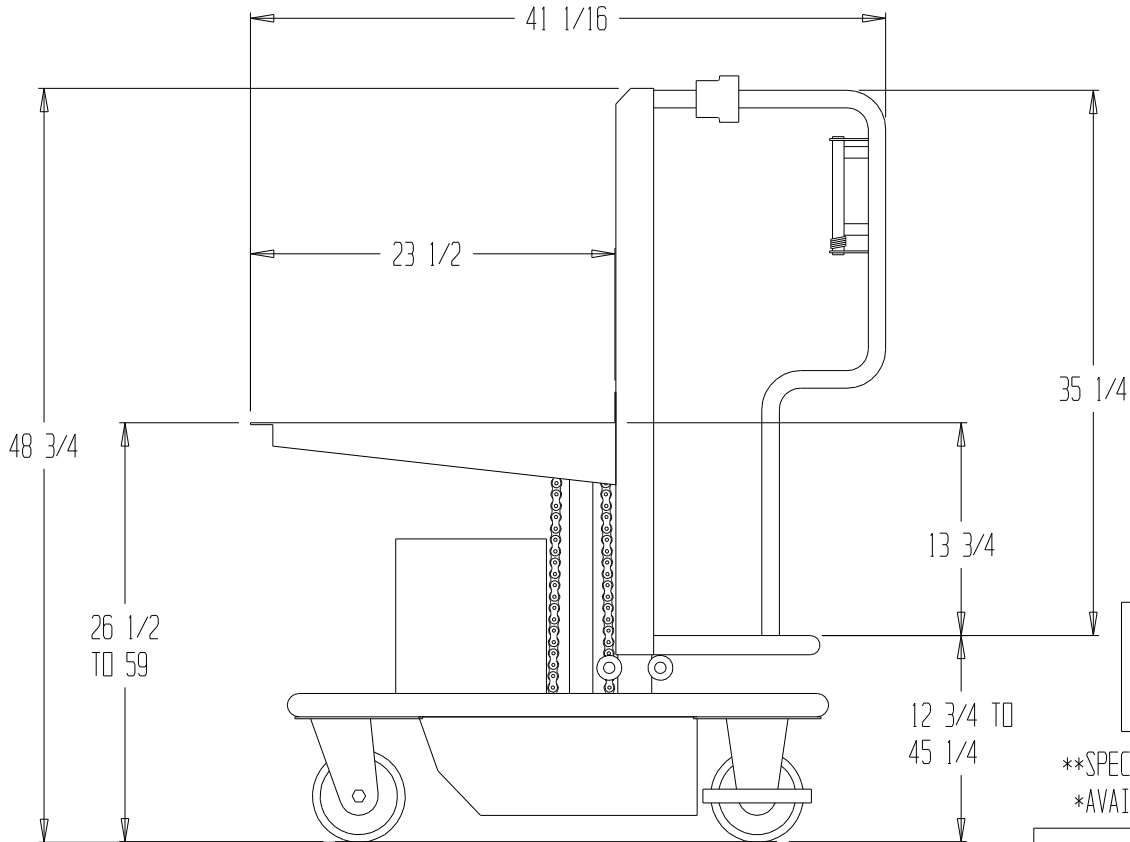
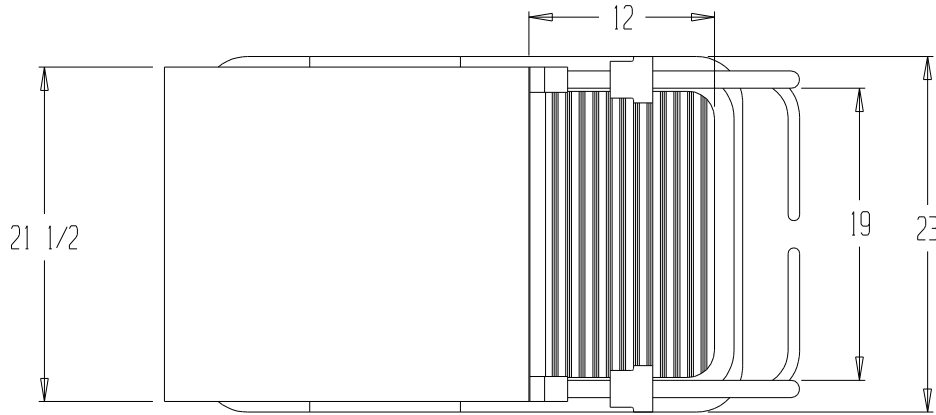

DIMENSION TOLERANCE $\pm 1/2"$

PRODUCTION WILL START UPON RECEIPT OF SIGNED APPROVAL DRAWING

**SPECIAL UNITS ARE NON-RETURNABLE
*AVAILABLE AT ADDITIONAL COSTS

All graphics provided are for reference only.
If certain dimensions are critical please verify those dimensions with your salesperson

STANDARD FEATURES

- MODEL NUMBER: EOP-440
- CAPACITY: 440 LBS
- OVERALL WIDTH: 23"
- OVERALL LENGTH: 41 1/16"
- OVERALL HEIGHT: 48 3/4"
- PRODUCT PLATFORM HEIGHT: 26 1/2" TO 59"
- OPERATOR PLATFORM HEIGHT: 12 3/4" TO 45 1/4"
- PRODUCT PLATFORM SIZE: 21 1/2" x 23 1/2"
- OPERATOR PLATFORM SIZE: 19" X 12"
- (2) - 6" x 1 1/2" SWIVEL CASTERS IN FRONT
- (2) - 6" x 1 1/2" RIGID CASTERS IN BACK
- DURABLE BAKED IN POWDER COATED YELLOW FINISH

SPECIAL FEATURES

NONE

APPROVAL	I, THE UNDERSIGNED, AGREE THAT THE PRODUCT AS REPRESENTED SATISFIES DESIGN & DIMENSION REQUIREMENTS. I ALSO ACKNOWLEDGE MY DUTY TO CONFIRM PRODUCT & INSTALLATION COMPLIANCE WITH ALL APPLICABLE FEDERAL, STATE AND LOCAL REGULATIONS & STANDARDS.	
	UNITS REQUIRING APPROVAL DRAWINGS OR MODIFIED ARE NON-RETURNABLE	
	() As drawn () As marked	
	Signed: _____	Date: _____
Printed Name: _____		
LEAD TIME WILL START UPON RECEIPT OF SIGNED APPROVAL DRAWING		

DISTRIBUTOR'S NAME: VESTIL MANUFACTURING		P.O. #: -
DRAWN BY: SR		DATE: 9-4-09
REFERENCE: -	SCALE: 1:12	SALES: -
QUOTED LEADTIME: -	QUOTE #: -	DRWG./FILE NAME: EOP-440