

FULLY POWERED ELECTRIC PALLET TRUCK, EPT-2047-30

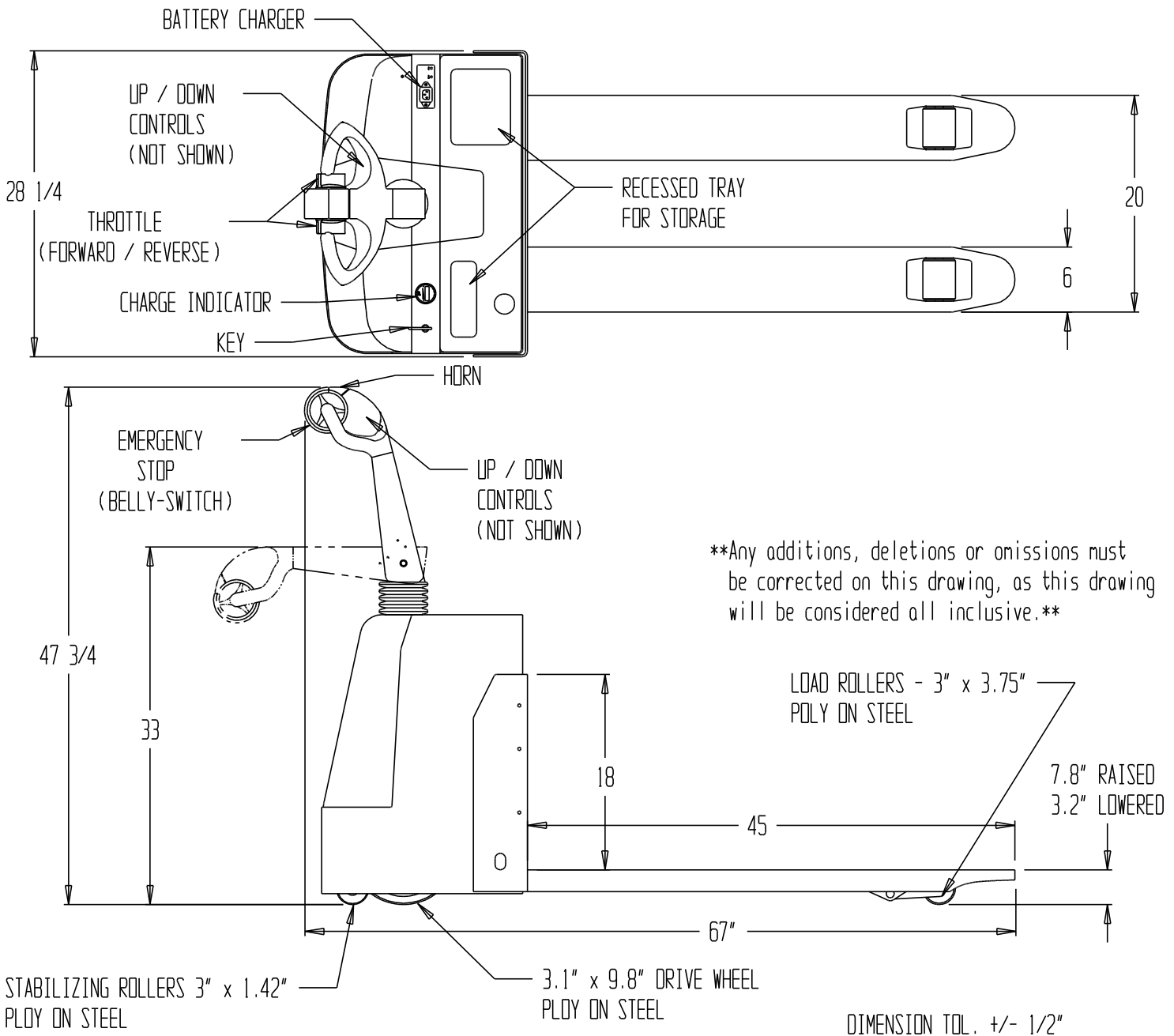

Any additions, deletions or omissions must be corrected on this drawing, as this drawing will be considered all inclusive.

DIMENSION TOL. +/- 1/2"

STANDARD FEATURES

- MODEL NUMBER: EPT-2047-30
- CAPACITY: 3,300 LBS.
- OVERALL FORK WIDTH: 20"
- USABLE FORK LENGTH: 45"
- FORK RAISED HEIGHT: 7.8"
- FORK LOWERED HEIGHT: 3.2"
- OVERALL WIDTH: 28 1/4"
- OVERALL LENGTH: 67"
- OVERALL HEIGHT: 47 3/4"
- 24V DC POWERED

SPECIAL FEATURES

NONE

PRODUCTION WILL START UPON RECEIPT OF SIGNED APPROVAL DRAWING

All graphics provided are for reference only. If certain dimensions are critical please verify those dimensions with your salesperson

FOR INTERNAL USE ONLY	A P P R O V A L I, THE UNDERSIGNED, AGREE THAT THE PRODUCT AS REPRESENTED SATISFIES DESIGN & DIMENSION REQUIREMENTS. I ALSO ACKNOWLEDGE MY DUTY TO CONFIRM PRODUCT & INSTALLATION COMPLIANCE WITH ALL APPLICABLE FEDERAL, STATE AND LOCAL REGULATIONS & STANDARDS. ANY MODIFIED UNITS ARE NON-RETURNABLE () As drawn () As marked Signed: _____ Date: _____ Printed Name: _____ LEAD TIME WILL START UPON RECEIPT OF SIGNED APPROVAL DRAWING
PROJECT SIGN OFF	
SALES	
ENG	
FAB.	
POWER	P.O.#: - W.O.#: - SALES: - SCALE: 1:14 DRWG.#/FILE NAME: EPT-2047-30

DISTRIBUTOR'S NAME: VESTIL MANUFACTURING		P.O.#: -
DRAWN BY: SR	DATE: 2-22-07	SALES: -
REFERENCE: -	SCALE: 1:14	DRWG.#/FILE NAME: EPT-2047-30
QUOTED LEADTIME: -	QUOTE #: -	

**SPECIAL UNITS ARE NON-RETURNABLE
*AVAILABLE AT ADDITIONAL COSTS