

ELECTRIC PALLET TRUCK WITH SCALE- EPT-2748-45-SCL

APPROX. WEIGHT: 1056 LBS.

*** ANY ADDITIONS, DELETIONS, OR OMISSIONS MUST BE CORRECTED ON THIS DRAWING AS THIS DRAWING WILL BE CONSIDERED ALL INCLUSIVE ***
 ALL GRAPHICS PROVIDED ARE FOR REFERENCE ONLY. IF CERTAIN DIMENSIONS ARE CRITICAL PLEASE VERIFY THOSE DIMENSIONS WITH YOUR SALESPERSON

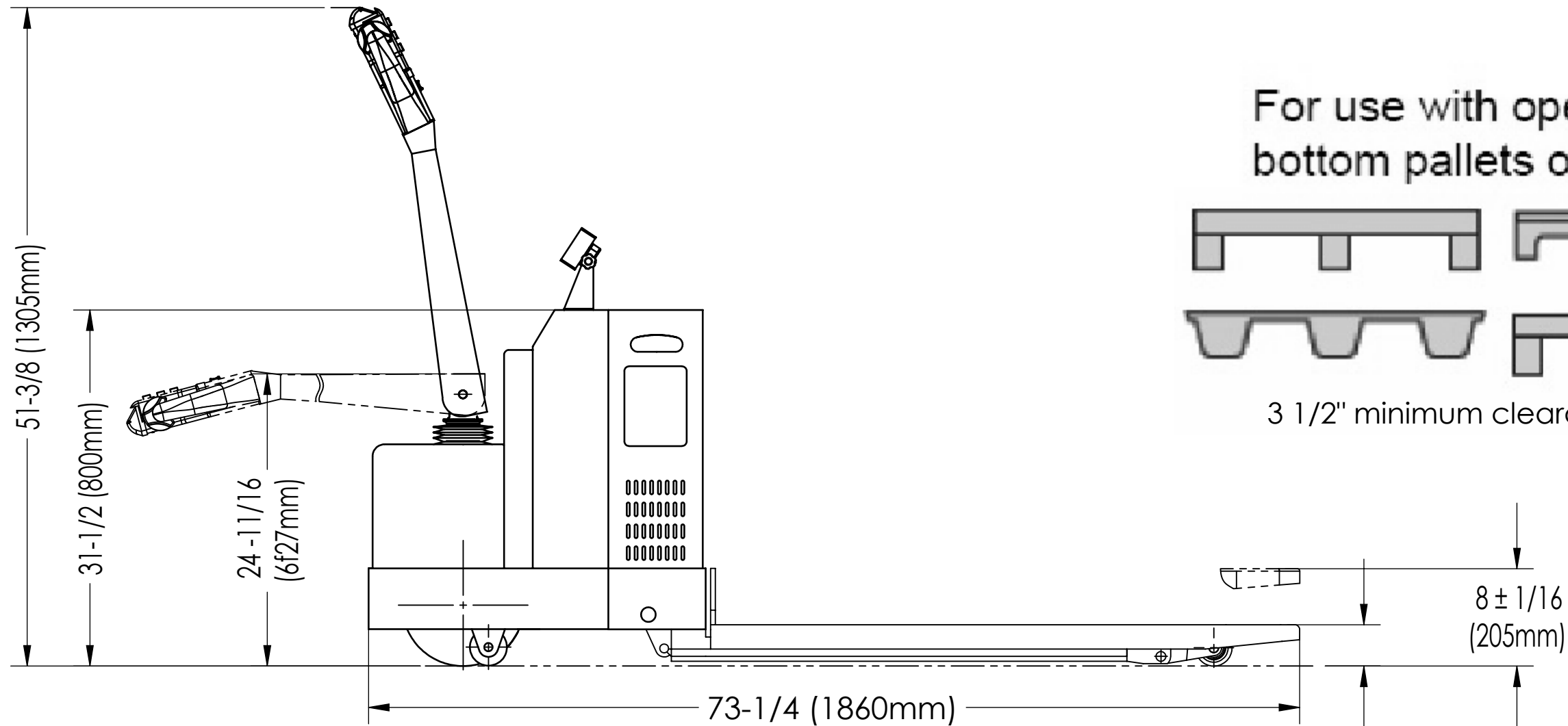

For use with open bottom pallets only

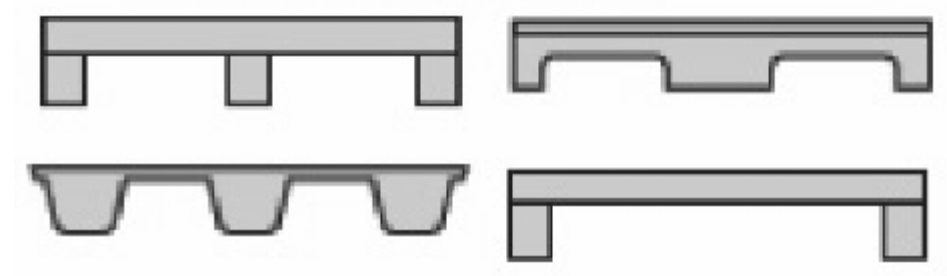

3 1/2" minimum clearance required

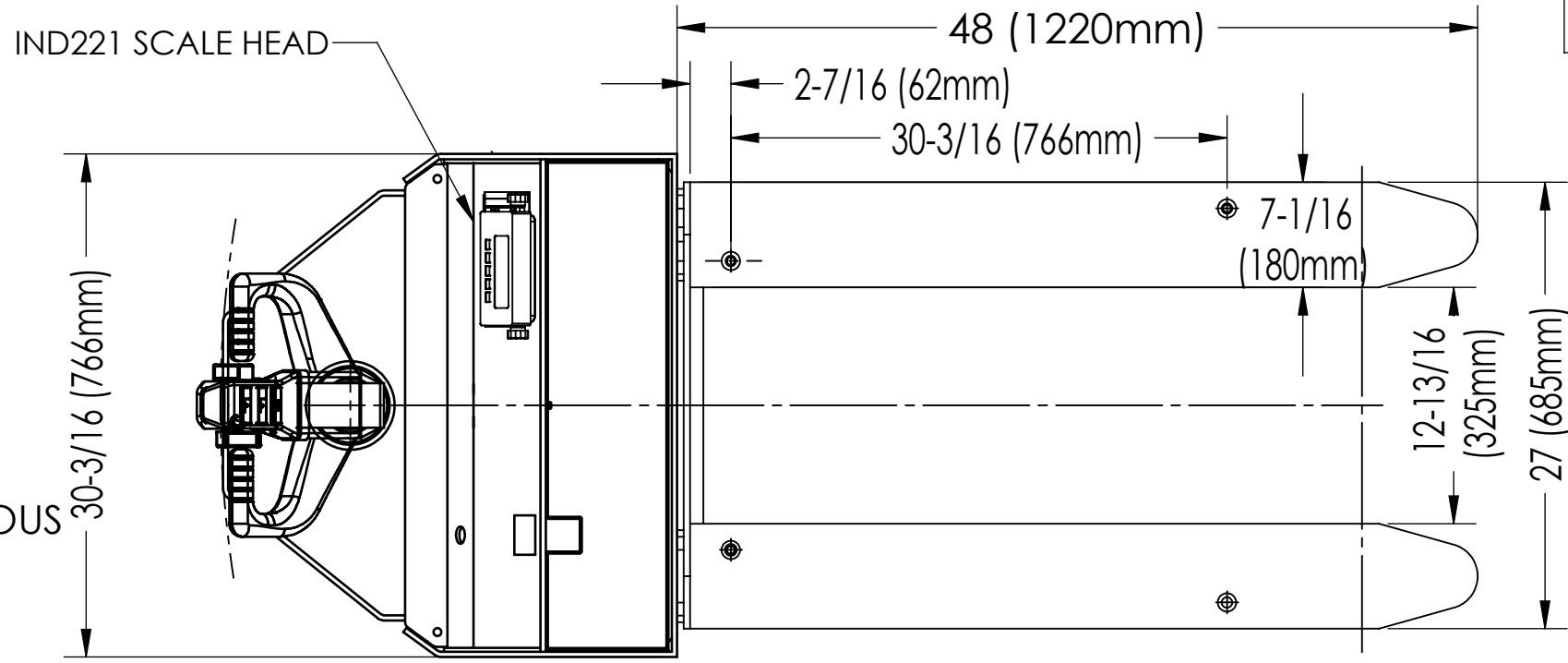

STANDARD FEATURES
 MODEL # EPT-2748-45-SCL
 CAPACITY: 4,500 LBS. CONTINUOUS
 LIFT HEIGHT: 8 ± 1/16"
 LOWERED HEIGHT: 3 3/8 ± 1/16"
 DRIVE WHEEL: Ø10 X 3 1/8"
 LOAD ROLLER: Ø2 3/4 X 2.9"
 TOUGH BAKED IN POWDER COATED
 BLACK & YELLOW FINISH

APPROVAL

I, THE UNDERSIGNED, AGREE THAT THE PRODUCT AS REPRESENTED SATISFIES DESIGN AND DIMENSION REQUIREMENTS. I ALSO ACKNOWLEDGE MY DUTY TO CONFIRM PRODUCT AND INSTALLATION COMPLIANCE WITH ALL APPLICABLE FEDERAL, STATE AND LOCAL REGULATIONS AND STANDARDS.
UNITS REQUIRING APPROVAL DRAWINGS OR MODIFIED ARE NON-RETURNABLE
 As drawn As marked

Signed: _____ Date: _____
 Printed Name: _____
 LEAD TIME WILL START UPON RECEIPT OF SIGNED APPROVAL DRAWING

DISTRIBUTOR'S NAME:		P.O.#
VESTIL MANUFACTURING		X
DRAWN BY: RLH		W.O.#
DATE: 1/3/2019		X
REFERENCE: X	SCALE: NTS	SALES: X
QUOTED LEAD TIME: X	QUOTE # X	FILE NAME: EPT-2748-45-SCL