

PALLET TRUCK WITH AGM BATTERIES, SCALE & RIDER PLATFORM - EPT-2748-45-SCLRPA GM

*** ANY ADDITIONS, DELETIONS, OR OMISSIONS MUST BE CORRECTED ON THIS DRAWING AS THIS DRAWING WILL BE CONSIDERED ALL INCLUSIVE ***

ALL GRAPHICS PROVIDED ARE FOR REFERENCE ONLY. IF CERTAIN DIMENSIONS ARE CRITICAL PLEASE VERIFY THOSE DIMENSIONS WITH YOUR SALESPERSON

APPROX WEIGHT: 1082 lbs.

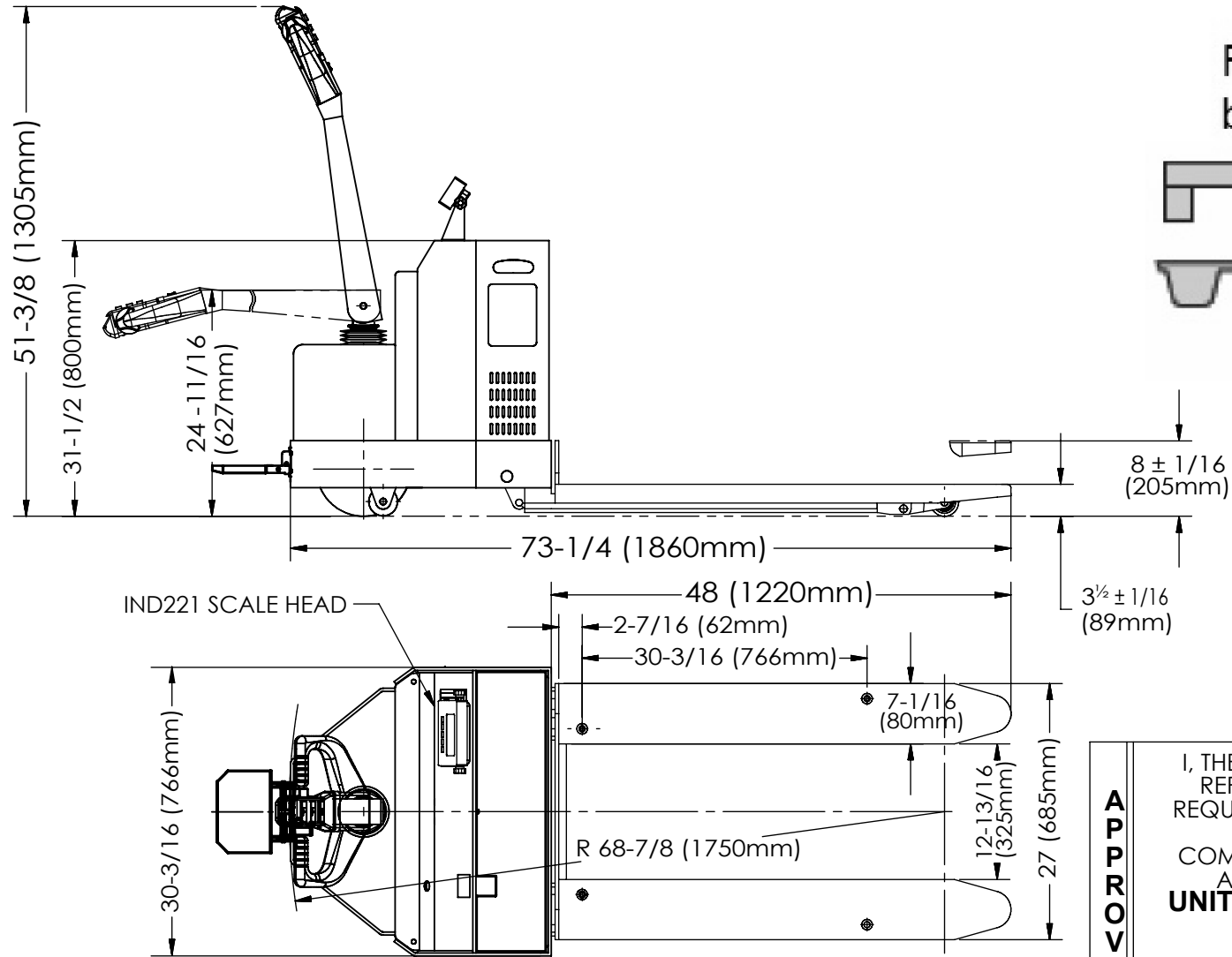

For use with open bottom pallets only

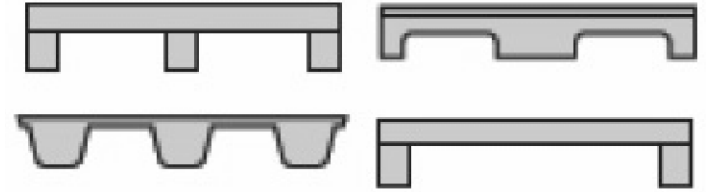

3 5/8" MINIMUM CLEARANCE REQUIRED

DIMENSION TOLERANCE ± 1/2"

STANDARD FEATURES

- MODEL NUMBER: EPT-2748-45-SCLRPA GM
- CAPACITY: 4500 LBS CONTINUOUS
- LIFT HEIGHT: 8 ± 1/16"
- LOWERED HEIGHT: 3 1/2" ± 1/16"
- DRIVE WHEEL: Ø10 X 3 1/8"
- LOAD ROLLER: Ø2 3/4 X 2.9"
- BATTERY: 4 x 6V / 210 Ah-AGM
- TOUGH BAKED IN POWDER COATED BLACK AND YELLOW FINISH

SPECIAL FEATURES

NONE

APPROVAL

I, THE UNDERSIGNED, AGREE THAT THE PRODUCT AS REPRESENTED SATISFIES DESIGN AND DIMENSION REQUIREMENTS. I ALSO ACKNOWLEDGE MY DUTY TO CONFIRM PRODUCT AND INSTALLATION COMPLIANCE WITH ALL APPLICABLE FEDERAL, STATE AND LOCAL REGULATIONS AND STANDARDS.

UNITS REQUIRING APPROVAL DRAWINGS OR MODIFIED ARE NON-RETURNABLE

[] As drawn [] As marked

Signed: _____ Date: _____

Printed Name: _____

LEAD TIME WILL START UPON RECEIPT OF SIGNED APPROVAL DRAWING

DISTRIBUTOR'S NAME:		P.O.#
VESTIL MANUFACTURING		X
DRAWN BY: TM		DATE: 5/31/2022
REFERENCE: X		SCALE: NTS
QUOTED LEAD TIME: X		QUOTE # X
		SALES: X
		FILE NAME: EPT-2748-45-SCLRPA GM