

Instruction Manual

EPT-S-2748-33 Semi-electric pallet truck



Operators should read and understand this manual and all warning labels on the Semi-electric pallet truck before using it.

Keep the manual for future reference.

Release: July. 2010

EG-Konformitätserklärung
EC Declaration of Conformity

Hiermit erklären wir,

NOBLELIFT EQUIPMENT

Jingyi Road, Changxing, Zhejiang, China

We herewith declare

Daß die nachfolgend bezeichnete Maschine aufgrund ihrer Konzipierung und Bauart sowie in der von uns in Verkehr gebrachten Ausführung den einschlägigen grundlegenden Sicherheits- und Gesundheitsanforderungen der EG-Richtlinien entspricht.

that the following machine complies with the appropriate basic safety and health requirements of the EC Directive based on its design and type, as brought into circulation by us.

Bei einer nicht mit uns abgestimmten Änderung der Maschine verliert diese Erklärung ihre Gültigkeit.

In case of alteration of the machine, not agreed upon by us, this declaration will lose its validity.

Bezeichnung der Maschine:

Elektrohubwagen

Machine Description:

Semi-electric pallet truck

Maschinentyp:

Machine Type:

SPT15

Einschlägige EG-Richtlinien: EG-Maschinenrichtlinie: 2006/42/EC

Applicable EC Directives: EC Machinery Directive: 2006/42/EC

Angewandte harmonisierte

Normen insbesondere:

Applicable Harmonized

Standards:

EN 1726:1998 EN1175-1:1998

Herstellerunterschrift/Datum:

Authorized Signature/Date:

Dec. 29, 2009

Angaben zum Unterzeichner:

Title of Signatory:

President

Preface

Welcome to use this series of Semi-electric pallet trucks SPT15. In order to ensure your safety and to correctly operate the shop crane, please thoroughly read and understand all instructions in the Instruction Manual as well as all label instructions before operating it for the first time. Please keep the Instruction Manual handy for reference whenever necessary.

This manual will tell about safety operation, main specifications and maintenance of this pallet truck.

To highlight some instructions, the following icons are used in this manual.



1.  ----refers to a potential danger; if not avoided, it may cause serious human injury, vehicle damage or fire.



2.  ----refers to a potential danger; if not avoided, it may cause minor human injury, or local damage to the vehicle.



3.  ---- Refers to general notes and instructions before use.



 Most parts of the product are made from recyclable steel. The recycling and disposal of cast-offs resulted during use, maintenance, cleaning and disassembling the product has to comply with local regulations without pollution to the environment. The recycling and disposal of the cast-offs should only be operated by specialised personnel in the designated area. The cast-offs such as hydraulic oil, batteries and electronic units, if improperly disposed, may be hazardous to the environment and human health.



 Due to continuous product improvement, Noblelift reserves the right to make changes in product designs and specifications without prior notice. For the latest product parameters, please feel free to contact us. Note: All parameters provided herein are as of the publication date of the Instruction Manual.

1 Guidelines for Safe Operation

1.1 Requirements for the operator

The pallet truck should only be operated by trained personnel.

1.2 The right, duty and responsibility of the operator

Clear with his own right and duty, the operator should be trained in operating the pallet truck and also knows the contents in this operation manual very well. If the Semi-electric pallet truck in use is controlled on foot, the operator should wear safety boots during operation.

The operator is responsible for managing the pallet truck in use, and must prevent any unauthorized person from driving or operating the pallet truck.

1.3 Malfunction and Defects: In case malfunction or defects occur with the Semi-electric pallet truck, the driver should immediately inform the supervisor. If the Semi-electric pallet truck can not be operated safely, e.g. with worn wheels and brake malfunction, always stop using it until repaired completely.

1.4 Repair

Do not disassemble and repair the truck on your own. Repairs performed by non-qualified personnel will degrade the safety factors of the truck. Attaching device or equipment that may interfere with or complement the pallet truck's functions can only be installed with the written approval of the manufacturer. If necessary, please call our technician.



All original spare parts from the factory are verified by Quality Assurance Department. Only use spare parts from the manufacturer for the guarantee of the safety and reliability of Semi-electric pallet truck operation. The replaced material such as oil or fuel should be disposed of according to environment protection regulations.

1.5 Dangerous area

Dangerous area generally refers to these locations, in which Semi-electric pallet truck or its lifting mechanism (e.g. fork or accessories) is moving, lifting or lowering, thus being dangerous to persons in this area, or in which the truck is handling loads. Generally the scope of this area extends to locations to which the loads or accessories on the truck is lowered.



Unauthorized persons must be ordered to leave dangerous areas. The driver should always give warning if there is any risk of human injury. If the warned persons still stay in dangerous area, the driver should stop the Semi-electric pallet truck immediately.

1.6 High-risk environment

Trucks that will be operated in high-risk environment must be equipped with special safety devices. If operated in fuel depots, the truck must be equipped with antistatic devices.

The truck is not designed for use in high-risk environment

1.7 Driving in public places: The truck is prohibited to drive in public places except for special areas.

1.8 Space between vehicles

Remember to keep a proper distance from the vehicle ahead, since it may stop suddenly at any moment.

1.9 Operation in a lift or loading platform

If the load capacity of the lift or platform is sufficient and the space is enough for Semi-electric pallet truck operation, they can be used for transportation with the permission from the Semi-electric pallet truck user. The Semi-electric pallet truck must be confirmed by its driver himself before entering the lift or loading platform. When entering the lift, the loads must enter ahead. And locate the Semi-electric pallet truck in a suitable position to prevent from contacting walls around. If passengers take the lift together with the Semi-electric pallet truck, they have to enter after the Semi-electric pallet truck enters and stops firmly, and leave before the Semi-electric pallet truck.



STOP The total weight is the weight of the load plus the weight of the truck itself.

1.10 Operation Management

Driving speeds must be suitable to local conditions. Always drive in lower speed when passing curved passageways, narrow passageways, rotary doors or any obstructed places. The driver should be able to measure by sight and keep enough stopping space from vehicles ahead all the time. It is prohibited to make an abrupt stop (unless in emergency), rapid U-turn and chase with each other in obstructed places.

1.11 Visibility

The driver must keep his eyes on moving direction and have a clear view of the road ahead. In case the loads carried block sight of the driver, the truck has to be driven reversely. If this is not practical, another person should walk in front of the truck, giving corresponding guidance and warning to the driver.

1.12 Passing a ramp

Only known ramps are permitted to pass. The ramps must also be clean, anti-skid and meet specification requirements of the truck. Loads on the fork must face the downward slope. Never turn around, drive obliquely or stop on a slope. Slow down when passing a ramp.

1.13 Safe Parking

Pay attention to safety when parking the truck. Never park the truck on a slope or on a ramp. The fork must be lowered down to the lowest position after parking. Turn off the electric lock and remove the key to prevent unauthorized operation.

1.14 Signalling

Warning signals can be sent by the horn on the truck.

1.15 Protection shoes

According to EU standard EN-345:1-S1, standard protective shoes must be worn when operating on the Semi-electric pallet truck.

2. Technical manual

The SPT15 Pallet Truck is specially designed for conveying goods on flat roads.

The maximum loading capacity is 1500kg, and the product's most important feature is that it is power-driven, avoiding labor force generally needed by operation of hand pallet truck and thus improving the working efficiency; the LPE20 Semi-electric pallet truck is particularly suitable for use in factories, plants, wharfs and small warehouses. It can also be used for handling goods on freight wagons.

2.1 Technical features

2.1.1 Structure drawing

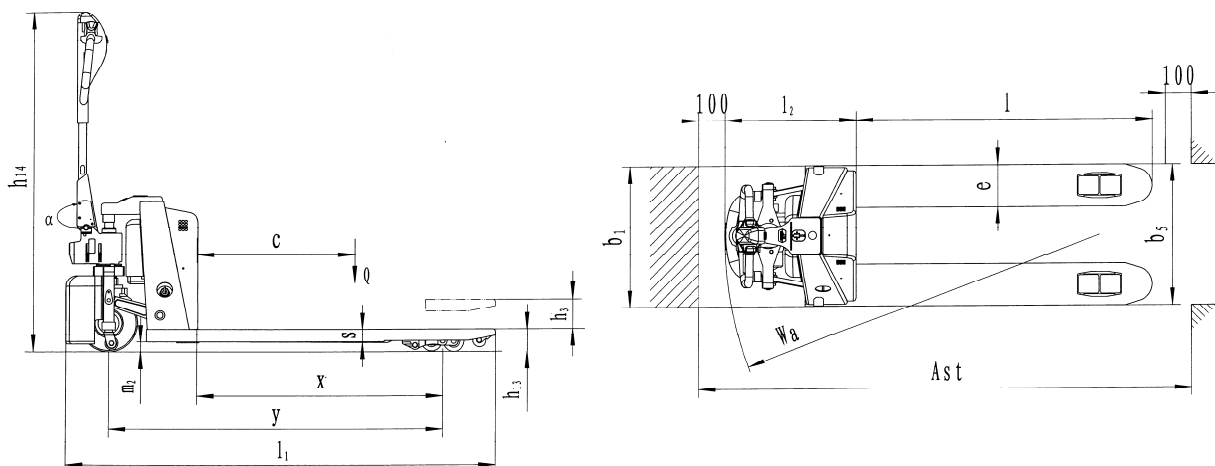

2.1.2 SPT15 Outline drawing and technical parameters

Features	1.2	Model		EPT-S-2748-33
	1.5	Rated loading capacity	Q lbs	3,000
	1.6	Load centre distance	C inch	23-5/8
	1.8	Front overhang distance	X inch	39-11/16
	1.9	Track	y inch	53
Weight	2.1	Weight (with accumulator)	lbs	73
Wheels	3.1	Wheels (rubber, high-performance elastomer, pneumatic tyre, polyurethane)		Polyurethane
	3.2	Dimension of driving wheel	inch	Ø8-11/16x2¼
	3.3	Dimension of front wheel	inch	Ø3-1/8x2¼ (PU)
	3.4	Dimension of castor	inch	Ø2x1-1/8 (Nylon)
	3.5	Wheel number (x = driving wheel) castor/front wheel		1x-2 / 4
Dimensions	4.4	Highest Fork Height	h ₃ inch	4½
	4.9	Handle Height	h ₁₄ inch	51.60
	4.15	Lowest Fork Height	h ₁₃ inch	3-3/8
	4.19	Overall length	l ₁ inch	67½
	4.20	Length (except the fork)	l ₂ inch	19-11/16
	4.21	Width of truck body	b ₁ inch	27
	4.22	Fork Dimension	s / e / l inch	1-7/8 / 6¼ / 48
	4.25	Lateral distance of fork	b ₅ inch	27
	4.32	Distance from wheel base centre to ground	m ₂ inch	1½
	4.34	Right angle stacking aisle width (800x1200)	Ast inch	84.40
	4.35	Turning radius	Wa inch	59.00
Performance	5.1	Driving speed full load/ no load	m/h	1.86/ 2.05
	5.8	Climbing capacity full load/no load	%	3 / 8
	5.10	Parking brake		Solenoid
Motor	6.1	Drive motor power	W	400
	6.4	Voltage/capacity of accumulator	V/Ah	2x12 / 40
	6.5	Accumulator weight (+/-5%)	lbs	9
		Box dimension of accumulator (L/W/H)	inch	7¼ / 6½ / 6-7/8

2.2 Technical Standards

Continuous noise level should be less than 70dB (A) according to ISO4871 standard.

Continuous noise level is an average value of noise measured at 1 meter distance from sides of the truck and 1 meter above the ground during travelling and lifting.

Electromagnetic Compatibility (EMC)

The manufacturer confirms that the truck complies with EN12895 and other relevant standards on limits of electromagnet radiation and interference, and has been tested on static discharge.

Never modify any part of electrical system without written permission from the manufacturer.

2.3 Operation Conditions

Ambient temperature: 5°C~40°C



Special devices have to be used under a temperature below 5°C or in very humid environment.

Operation area: below an elevation of 2000 meters.

3 Transport and Trial Run

3.1 Loading and Unloading



This truck acquires wooden block packaging; so it can be loaded or unloaded with a forklift and a crane.

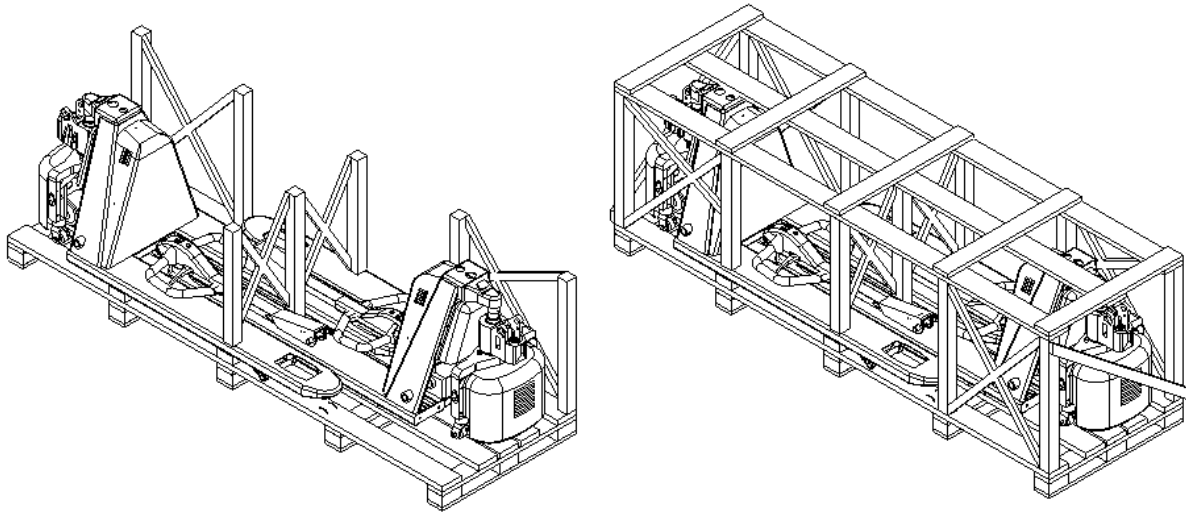

3.2. Installation of Handle

You may need some tools for installation, such as a hammer and a pair of pliers, etc.; you also need some accessories: a perforated shaft, two spring pins (note: one has been installed on the shaft). The accessories are placed in a plastic bag taped around the handle.

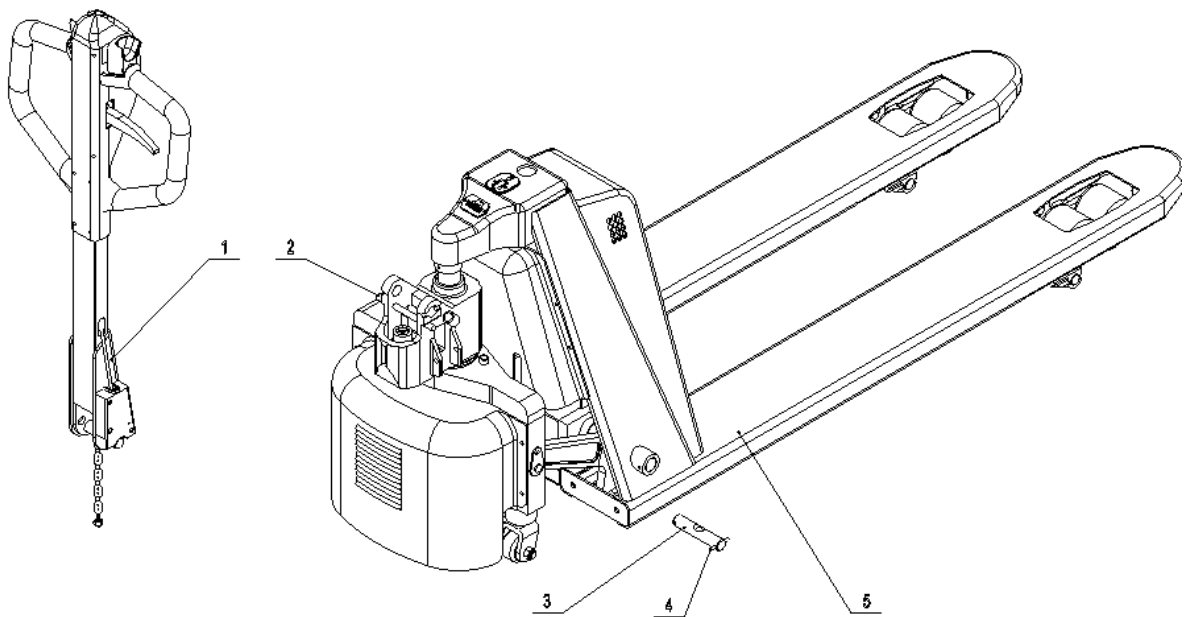

1. Handle 2. Pin roll 3. Perforated pin 4. Spring pin 5. Main frame

Squat behind the truck when installing the handle and follow the steps below:

3.2.1 Place the handle on the small piston, and then use a hammer to knock the perforated pin into the hydraulic pump and handle from right to left.

3.2.2 Shift the finger lever to the "**Lowering**" position and insert the adjustment nut , adjusting bolt and chain through the center hole of pin.

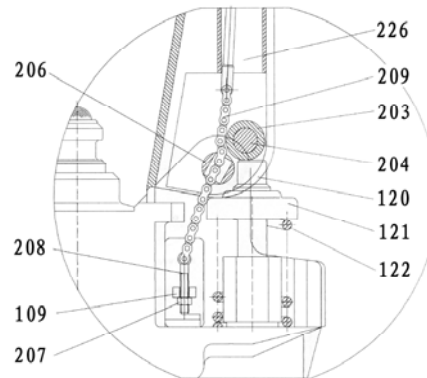
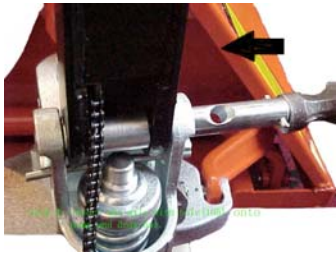

3.2.3 Press the handle bar and remove the pin.

3.2.4 Place the control handle to "**Lifting**" position, then tilt up the swing rod, insert the adjusting bolt into the slot in front of the rod, and make adjusting nut affixed to the bottom of the swing rod;

3.2.5 Use a hammer to knock the elastic pin into perforated pin.

The handle installation is completed.

3.3 Three-Position (Lifting, Neutral and Lowering) Finger Lever Adjustment

The finger lever has three positions and their functions are as follows:

Lifting The finger lever is at the low position. With an up/down motion of the handle, the fork can be raised.

Neutral The finger lever is at the middle position. With an up/down motion of the handle, the fork will not be lowered or raised. It is use for truck moving.

Lowering The finger lever is at the high position, and the fork will be lowered. Release the lever, it will automatically return to the neutral position.

The three positions of the finger lever have been adjusted before leaving the factory. If the positions change due to accident, adjust according to the following steps:

3.3.1 If the fork rises when the finger lever is pressed at the middle position, turn the adjusting screw or the adjusting nut on the adjustment bolt clockwise until the fork neither rises nor lowers when the

finger lever is being pressed.

3.3.2 If the fork lowers when depressing the finger lever at the middle, turn the adjusting screw or the adjusting nut counter clockwise until the fork does not lower when the finger lever is being pressed.

3.3.3 If the fork does not lower when pressing the finger lever to the “lower” position, turn the adjusting screw or the adjusting nut clockwise until the fork lowers when the finger lever is being placed at the position. Then check the middle position according to 3.1 and 3.2 to ensure normal function of Neutral position.

3.3.4 If the fork fails to lift when pressing the finger lever to the lifting position, turn the adjusting screw or the adjusting nut counter clockwise until the forks lifts. Then check the lowering and neutral position according to 3.1, 3.2 and 3.3 to ensure normal function.

3.4 Installation of lever wire

- ① First, use tools (screwdriver) remove the protection cover from the lever.
- ② Find the female connector of the wire under the top cap.
- ③ Firmly connect the female connector and the male connector of the lever wire.
- ④ Finally, use screwdriver to secure the protection cover with screws.

The installation of the handle wire is completed.

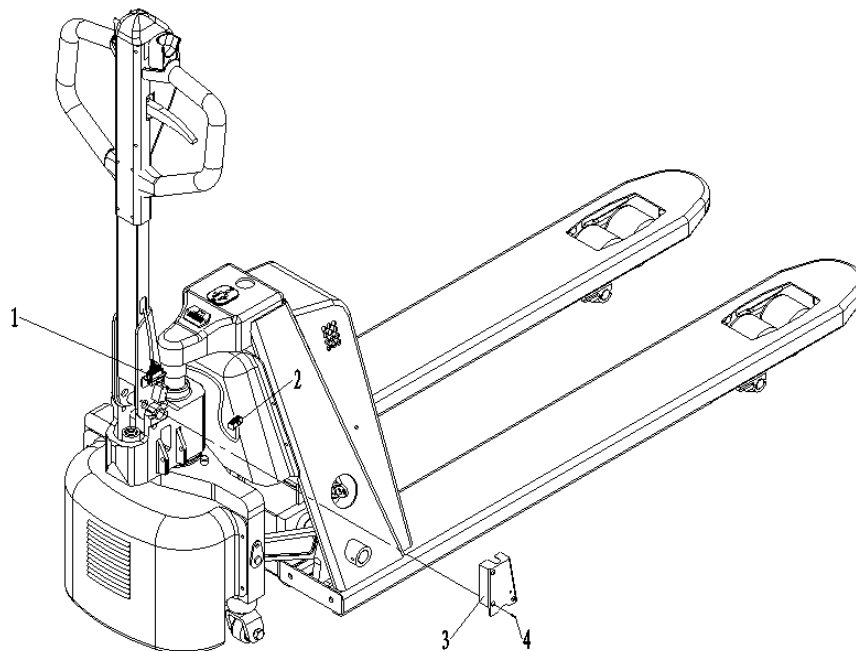

1. Male connector 2. Female connector 3. Protection cover 4. Screws

4 Operational Manual

4.1 Lever Operation

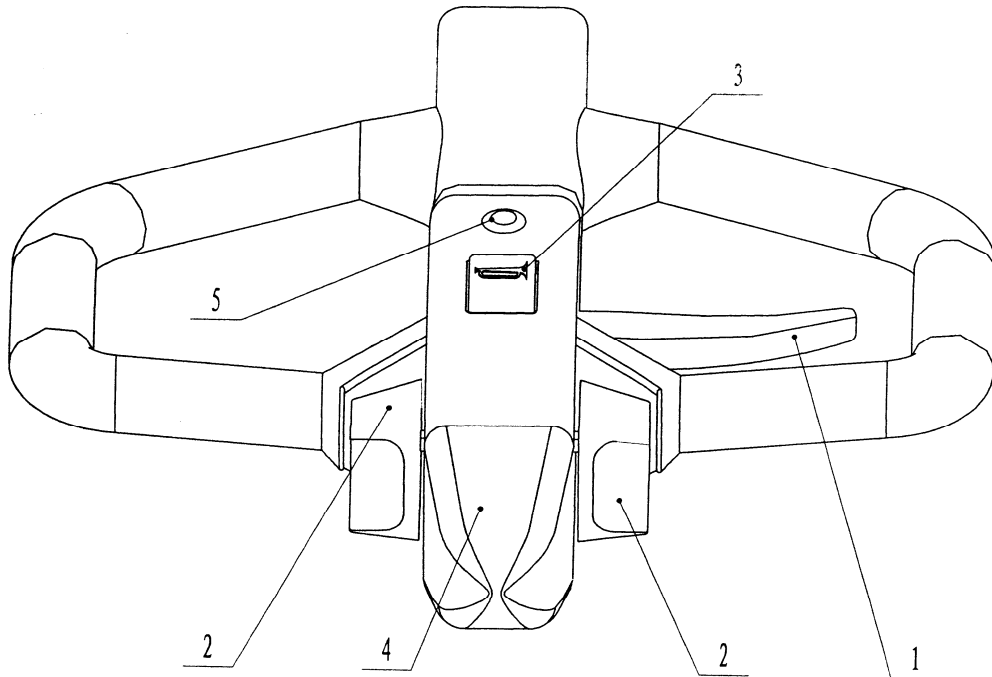

4.1.1 Finger Lever: Three Positions “Lifting, Neutral and Lowering” (see section 3.3) can be used to raise and lower the fork.

4.1.2 Drive switch: controls the speed and direction (forward and backward) of vehicle traveling.

4.1.3 Horn button:

4.1.4 Approach switch: Press the approach switch, the truck will stop immediately and drive a little towards the opposite direction.

4.1.5 Button switch: Press down the button switch, the control circuit is disconnected from power and all operation of the truck stops.

4.2 Starting-up the truck



Before start up the truck or lift the fork, please ensure no one stays within the dangerous area of the truck.

Check before daily start-up

- Check if there are any external defects (especially wheels and fork);
- Check the connection of accumulator and other wiring.

Start-up of the truck:

- Turn on key switch;
- Press button switch;
- Coulombmeter displays the residual capacity;

- Check the horn;
- Check the brake function of the lever.

Now, prepare work before start-up is completed.

4.3 Operation

4.3.1 Start-up, Drive, Stop



Before starting-up and driving the truck, you should warn other people, especially when they are in contact with the truck. The operator must note that it is prohibited to transport or lift personnel with the truck.

Emergency Stop

In case of emergency, press the button switch at once, the truck will stop immediately.

Forced Brake

Release the lever and the lever becomes vertical (or press the lever until it becomes horizontal), the truck will stop automatically.

Start-up

Driving speed is controlled by the finger lever:

- Press the finger lever to a proper position;
- Adjust the lever towards desired direction.

Driving

After start-up, use your thumb to rotate two drive switches: if the switch is turned forwards, the truck moves forwards; if the switch is turned backwards, the truck moves backwards.

The speed of forward and backward will be controlled by the rotating angle of drive switch. When start-up or the ambient space is small, the turning angle should be smaller.

Passing a ramp



The loads must face downwards when transporting them on a slope; the operator must note the safety capacity when transporting downwards on a slope. With the drive switch in position "0", pull the lever backward at once and control the speed and direction of the truck to drive downward a slope; if necessary, use emergency stop or forced brake.

Braking



The operator must note that braking entirely depends on the road conditions. Three braking

methods are available:

- Electromagnetic brake (finger lever)
- Reverse current brake (from the controller)
- **Inertia brake (Release the brake)**

Electromagnetic brake



In case of emergency, the truck can be only stopped with electromagnetic brake (press button switch, or leave the finger lever as vertical or press it as horizontal).

- Press button switch at once



Disconnect the control circuit from power through button switch and thus electromagnetic brake cause the truck to skid.

- Leave the finger lever as vertical or press it as horizontal



Disconnect the control circuit from the power through the proximity switch of the lever and the electromagnetic brake will therefore cause the truck to brake.

Reverse current brake



If the control system or driving power fails, braking with reverse current is possible.

- Rotate the drive switch towards the opposite direction until the truck stops.
- Then release the drive switch.

Inertia brake

- Release the drive switch, it will reset automatically. The driving inertia of the truck causes it to stop slowly and steadily. The forward and backward speed will be controlled by the rotating angle of the drive switch.



If the controller position is set to '0' and the inertia braking unit is removed by a service technician, you have to use the electromagnetic brake or reverse current brake to brake the truck.

4.3.2 Lift and lower the fork



Before transport, the operator must make sure the goods are properly loaded on the fork and the weight is within the capacity of the truck. Do not transport in full load status for a long time.

- The fork should be totally extended underneath the load.
- To lift or lower the loads, operate the finger lever (217) to the position "**Lifting**" or "**Lowering**".

Lifting of the fork

- The finger lever (217) is at the “**Lifting**” position. With an up/down motion of the handle, the fork can be raised.
- The finger lever (217) is at the “**Lowering**” position, the fork can be lowered.

5 Maintenance, Recharging and Replacement of the Accumulator

5.1 Safety procedures for accumulator operation

The truck must be parked in a safe location before any operation on the accumulator.

5.1.1 Maintenance Technician

Only a qualified technician can perform operations on the accumulator such as recharging, maintenance and replacing. Before operation, carefully read instruction manuals including operation manual, replenishment preparation and recharging requirements.

5.1.2 Fire Prevention Measures

Never smoke or use open fire when performing operations on the accumulator. The accumulator should be at least two meters away from flammable material when storing or recharging. The area for accumulator operation should be well ventilated and equipped with fire fighting devices.

5.1.3 Maintenance of the Accumulator

- 1) Keep the nuts of the accumulator clean and dry. Exposed cable ends and terminal posts should be covered with a skid-proof insulating cover.
- 2) The wires should be well-connected. Check the screw bolts on each pole, if loose, tighten the nuts.
- 3) Over recharging and over discharging should be avoided, and fast charging and insufficient recharging are also not allowed. Otherwise the life span of the accumulator may be affected.
- 4) Do not put conductive objects (including metal tools) on the accumulator, or short circuit or even explosion may be caused.
- 5) Recharge the discharged accumulator in time. Delayed recharging may damage the accumulator. Do not delay recharging more than 24 hours. Recharging of the accumulator may not work outdoors in cold weather. In this case, move it indoors to perform recharging.
- 6) If the accumulator will not be in use for a long time, it should be recharged and discharged once every month and it should be fully recharged every time.
- 7) The site for recharging should be well ventilated. It is prohibited to smoke or use open fire, avoiding the risk of explosion.
- 8) The electrolytic solution of the accumulator is poisonous and corrosive, so it is prohibited to put the accumulator upside down under any circumstances.

5.1.4 Disposal of worn-out accumulators

Worn-out accumulators should be recycled according to local regulations, and stored in specified zone or cast-off treatment zone. This work should be carried out by qualified specialized companies.

5.2 Specification of the accumulator

Weight and dimensions can be found on the label of the accumulator.

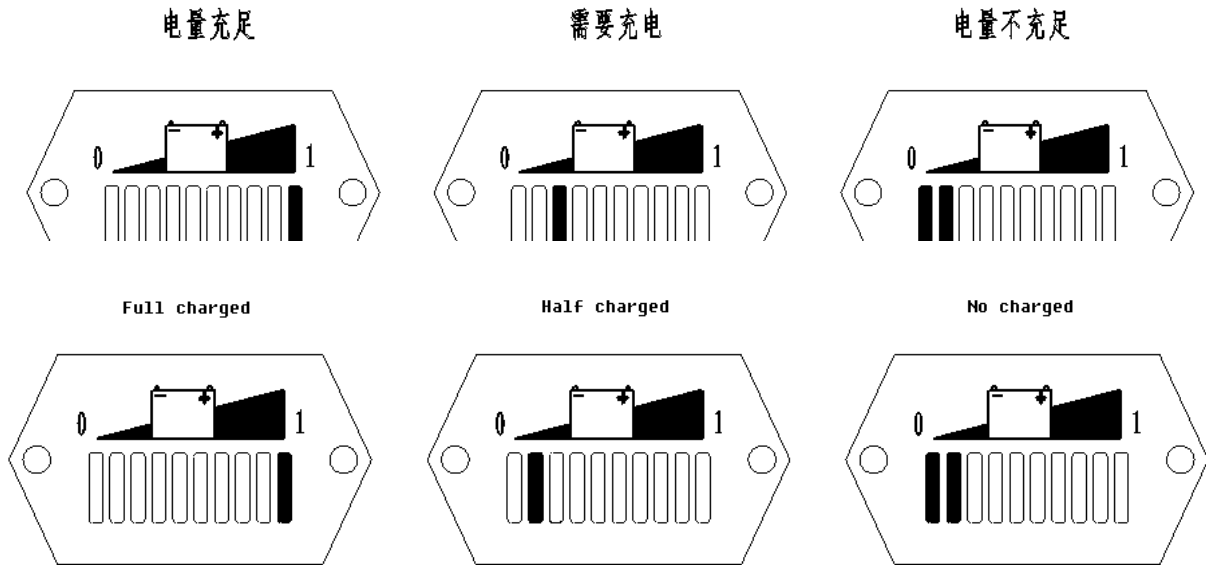

Before charging, the truck should be parked in a closed, well-ventilated room



The charging of the accumulator should be done according to corresponding instruction manual of accumulator and charger. Accumulators that did not get used for a long time should be charged before use.

You should charge the accumulator when the remaining capacity is 30%:

Fully-automatic charging: this truck is equipped with a built-in, fully-automatic and intelligent charger. Just connect the input of the charger with the power outlet; the charger will automatically adjust the charging current according to the residual capacity, ensuring an optimal charging status. After charging, the charging will automatically stop and power off. The accumulator needs about 8-10 hours to be fully charged.

5.5 Replacement of accumulator



Please replace the accumulator immediately when it has been damaged.

6 Maintenance and Service Manual

The Semi-electric pallet truck needs frequent daily inspection and maintenance.

6.1 Daily Inspection & Maintenance

① **Hydraulic oil:** Check the hydraulic oil every 6 months. The capacity is 0.3 Liter. Please select the suitable hydraulic oil according to the table below.

Temperature	Hydraulic Oil
+5°C~+40°C	L-HV46 hydraulic oil

② **Exhaust air:** Air might enter into the hydraulic oil during transportation operation or when the pallet truck is placed upside down. In such case, when pumping the handle with the control lever at the **lifting** position, the fork will not raise. Remove the air by using the following method: pull the finger lever (217) to the lowering position, and then pump the handle bar (211) up and down several times.

③ **Lubrication:** All the bearings and shaft levers have been applied with a long-lasting lubricant at the factory. All you need to do is apply the lubricant to wherever lubrication is needed at monthly intervals or each time after a thorough cleaning.

④ **Maintenance:** Proper daily inspection and maintenance can extend the service life of the Semi-electric pallet truck. Particular attention must be paid to check the wheels and wheel axels for cotton threads, cloth and other foreign objects, which will get twisted around the wheels. Always remove the load from the fork and lower the fork to the lowest position when the job is completed.

The operator should perform maintenance of the pallet truck everyday. Take the following steps:

1	Check the oil pump for any oil leakage
2	Check button switch
3	Check proximity switch
4	Check the horn
5	Check the drive switch of control lever
6	Check wheels and fork
7	Check the charger

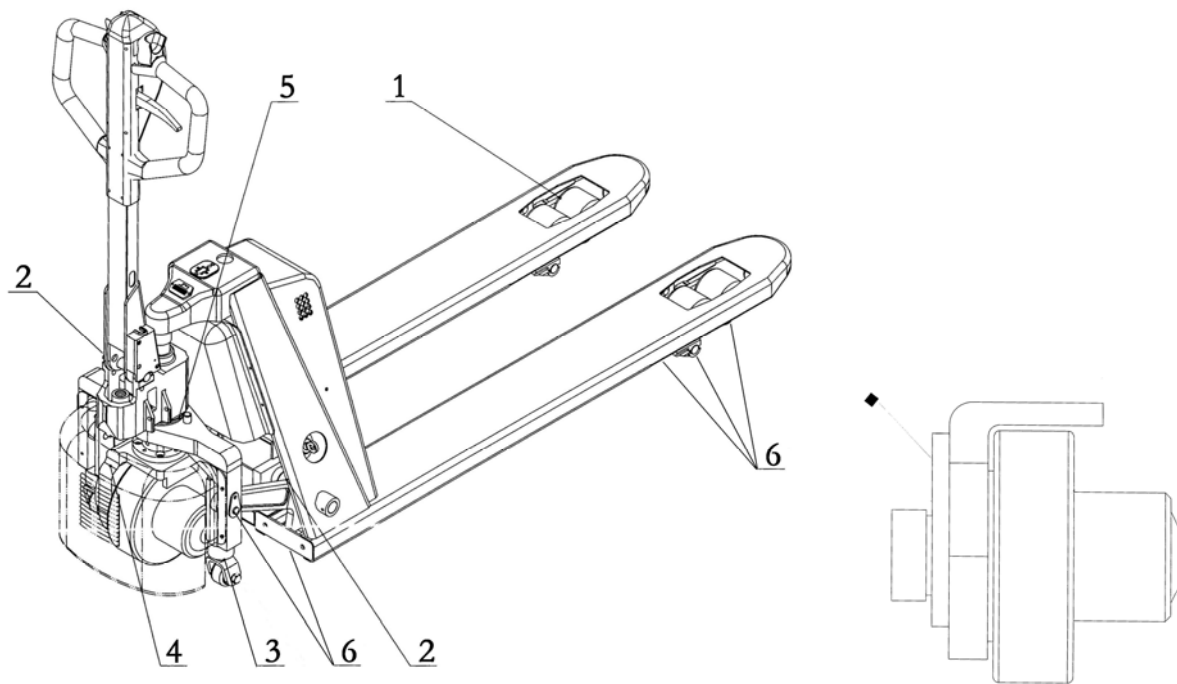

Lubrication Cycle Table

◆ = Refill opening

No.	Refill point	Lubrication Cycle			
		500 h	1000 h	2000h	
1	Bearings in loading wheels	L			A
2	Shaft sleeve	L			B
3	Bearings in supporting wheels	L			C
4	Gear box	C		L	D
5	Steering bearing	L			E
6	Joints	L			F

L=Lubricating C=Checking

Description tables of oil and lubricant

Lubricant type		Lubricant Name		Lubricated area
		>-15°C	<-15°C	
A	Lubricant grease	2# Jinzhi grease	2# Jinzhi grease	Bearing
B	Lubricant grease	2# Jinzhi grease	2# Jinzhi grease	Shaft sleeve
C	Lubricant grease	2# Jinzhi grease	2# Jinzhi grease	Bearing
D	Hydraulic Oil	W85-90 Gear oil	W85-90 Gear oil	Gear box
E	Lubricant grease	2# Jinzhi grease	2# Jinzhi grease	Bearing
F	Lubricant grease	2# Jinzhi grease	2# Jinzhi grease	Joints

6.2. Troubleshooting

This chapter provides a guide to users on finding out and solving simple faults of the pallet truck.

The following table introduces faults determination and solving methods.

No.	Faults	Cause	Countermeasures
1	The fork frame can't reach the maximum height	- Low hydraulic oil level	- Add hydraulic oil
2	The fork frame can't be raised	- No hydraulic oil - Hydraulic oil is impure - The adjustment nut (207) is adjusted too high or the adjustment screw (111) is adjusted too close, making the relief valve open - There is air in the hydraulic oil	- Add hydraulic oil - Replace the hydraulic oil - Readjust the adjustment nut (207) or adjustment screw (111) (see section 3.4) - Pump air out (see section 4.2)
3	The fork frame can't be lowered	- Main piston (118) or pump (112) is damaged due to side-loading or overloading - The fork frame is rusted and hard to move due to long-term exposure to the air when the fork frame stays in the raised position for an extended period of time - The adjustment nut (207) or adjustment screw (111) is not adjusted properly	- Replace the piston (118) or oil pump body (112) - Please lower the fork to the lowest position when you do not use the crane, and make sure to lubricate the piston rod in time - Readjust the adjustment nut (207) or adjustment screw (111) (see section 3.3)
4	Oil leakage	- The sealing parts are aged or damaged - Some parts are broken	- Replace the parts - Replace the parts
5	Fork lowers itself	- The relief valve is unable to be shut tightly due to impure hydraulic oil - Some parts of the hydraulic system are broken or damaged - Air is mixed in the hydraulic oil - The sealing parts are aged or damaged - The adjustment nut (207) or adjustment screw (111) is not adjusted properly	- Replace the hydraulic oil - Check and replace the parts if necessary - Pump air out (see section 4.2) - Replace the parts - Readjust the adjustment nut (207) or adjustment screw (111) (see section 3.2)
6	Can't move forward or backward	- Accelerator is aged - The wires are aged or damaged - The controller gives a warning. - The controller is damaged. - Main contactor is damaged	- Replace the accelerator - replace the wires - Look for fault code and solve the problems - Replace the controller - Repair or replace the main contactor
7	Horn don't sounds	- The horn button is damaged - The wires are aged or damaged - The connector gets loose or falls off	- Replace the horn button - replace the wires - Check the connectors and secure them

8	Emergency changeover fails	<ul style="list-style-type: none"> - The proximity switch is damaged - The wires are aged or damaged - The connector gets loose or falls off 	<ul style="list-style-type: none"> - Replace the proximity switch - replace the wires - Check the connectors and secure them
9	Emergency stop switch is out-of-service	<ul style="list-style-type: none"> - The Emergency stop switch is damaged - The wires are aged or damaged - The connector gets loose or falls off 	<ul style="list-style-type: none"> - Replace the emergency stop switch - replace the wires - Check the connectors and secure them
10	Coulombmeter don't displays	<ul style="list-style-type: none"> - The coulombmeter is damaged - The connector gets loose or falls off - The wires are aged or damaged 	<ul style="list-style-type: none"> - replace the coulombmeter - Check the connectors and secure them - replace the wires
11	The indicator do not lights when press the lever indicator button	<ul style="list-style-type: none"> - The indicator button is damaged - The connector gets loose or falls off - The wires are aged or damaged - The relay of charging controller is damaged and whole vehicle is inoperative 	<ul style="list-style-type: none"> - Replace the indicator button - Check the connectors and secure them - replace the wires - Replace the relay of charging controller or replace the charger



If above steps still can not solve the problems, please contact the after-sales service department of the manufacturer and have the problems solved by specially trained technicians.

9. WIRING/ CIRCUIT DIAGRAM

a. Electrical circuit diagram

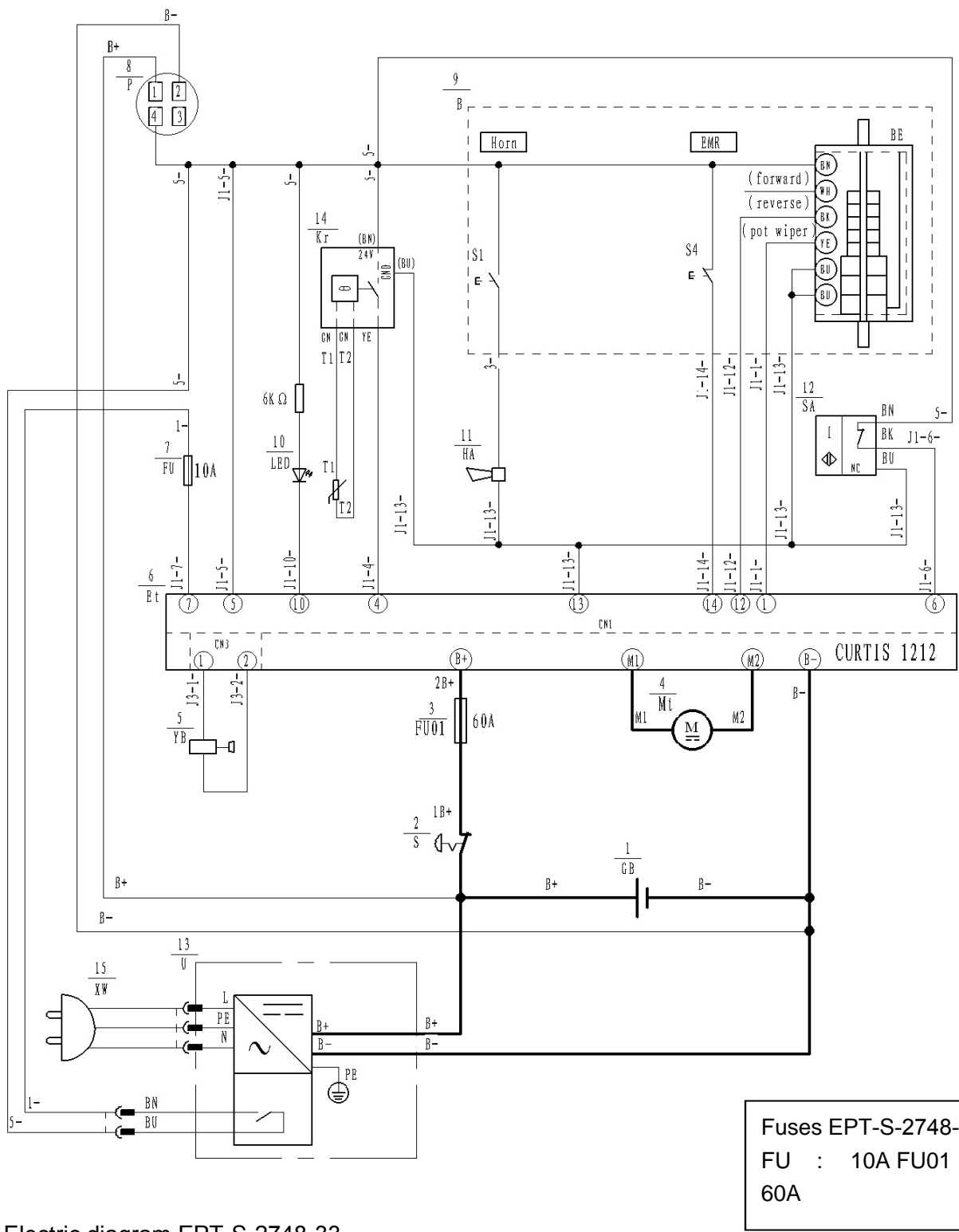
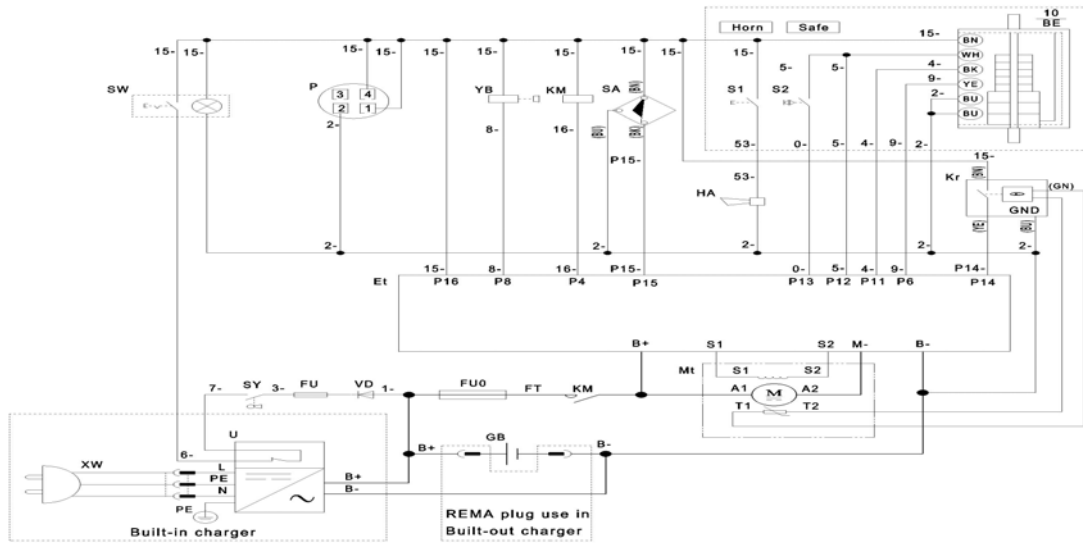

Fig. 22: Electric diagram EPT-S-2748-33

7 Schematic Diagram

7.1 Circuit diagram



The following are names of electric components:

No.	Code	Name	9	SA	Proximity switch
1	GB	Accumulator	10	S1、S2	Micro-switch
2	FU0、FU	Fuse	11	SY	Key switch
3	KM	Main contactor	12	BE	Accelerator
4	U	Charger	13	Kr	Temperature protective module
5	SW	Button switch	14	YB	Electromagnetic brake
6	Et	Controller	15	P	Coulombmeter
7	Mt	Traction motor	16	VD	Diode
8	HA	Horn	17	XW	Spring

LIMITED WARRANTY

Vestil Manufacturing Corporation (“Vestil”) warrants this product to be free of defects in material and workmanship during the warranty period. *Our warranty obligation is to provide a replacement for a defective original part if the part is covered by the warranty, after we receive a proper request from the warrantee (you) for warranty service.*

Who may request service?

Only a warrantee may request service. *You are a warrantee if you purchased the product from Vestil or from an authorized distributor AND Vestil has been fully paid.*

What is an “original part”?

An original part is a part used to make the product as shipped to the warrantee.

What is a “proper request”?

A request for warranty service is proper if Vestil receives: 1) a photocopy of the Customer Invoice that displays the shipping date; AND 2) a written request for warranty service including your name and phone number. Send requests by any of the following methods:

Mail
Vestil Manufacturing Corporation
2999 North Wayne Street, PO Box 507
Angola, IN 46703

Fax
(260) 665-1339
Phone
(260) 665-7586

Email
sales@vestil.com

In the written request, list the parts believed to be defective and include the address where replacements should be delivered.

What is covered under the warranty?

After Vestil receives your request for warranty service, an authorized representative will contact you to determine whether your claim is covered by the warranty. Before providing warranty service, Vestil may require you to send the entire product, or just the defective part or parts, to its facility in Angola, IN. The warranty covers defects in the following *original* dynamic components: motors, hydraulic pumps, electronic controllers, switches and cylinders. It also covers defects in *original* parts that wear under normal usage conditions (“wearing parts”): bearings, hoses, wheels, seals, brushes, batteries, and the battery charger.

How long is the warranty period?

The warranty period for original components is 1 year. The warranty period begins on the date when Vestil ships the product to the warrantee. If the product was purchased from an authorized distributor, the period begins when the distributor ships the product. Vestil may extend the warranty period for products shipped from authorized distributors by *up to 30 days* to account for shipping time.

If a defective part is covered by the warranty, what will Vestil do to correct the problem?

Vestil will provide an appropriate replacement for any *covered* part. An authorized representative of Vestil will contact you to discuss your claim.

What is not covered by the warranty?

1. Labor;
2. Freight;
3. Occurrence of any of the following, which automatically voids the warranty:
 - Product misuse;
 - Negligent operation or repair;
 - Corrosion or use in corrosive environments;
 - Inadequate or improper maintenance;
 - Damage sustained during shipping;
 - Collisions or other incidental contacts causing damage to the product;
 - Unauthorized modifications: DO NOT modify the product IN ANY WAY without first receiving written authorization from Vestil. Modification(s) might make the product unsafe to use or might cause excessive and/or abnormal wear.

Do any other warranties apply to the product?

Vestil Manufacturing Corp. makes no other express warranties. All implied warranties are disclaimed to the extent allowed by law. Any implied warranty not disclaimed is limited in scope to the terms of this Limited Warranty.

