

# ELECTRIC PALLET TRUCK W/ SINGLE FORK - EPT-SF-1232-26

APPROX WEIGHT: 290 lbs.  
 DOES NOT INCLUDE WEIGHT OF POWER OR PACKAGING!!!

\*\*\* ANY ADDITIONS, DELETIONS, OR OMISSIONS MUST BE CORRECTED ON THIS DRAWING AS THIS DRAWING WILL BE CONSIDERED ALL INCLUSIVE \*\*\*

ALL GRAPHICS PROVIDED ARE FOR REFERENCE ONLY. IF CERTAIN DIMENSIONS ARE CRITICAL PLEASE VERIFY THOSE DIMENSIONS WITH YOUR SALESPERSON

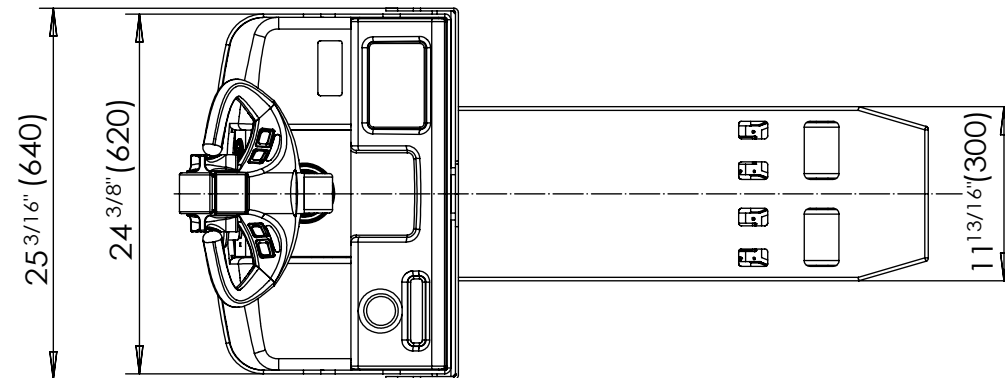
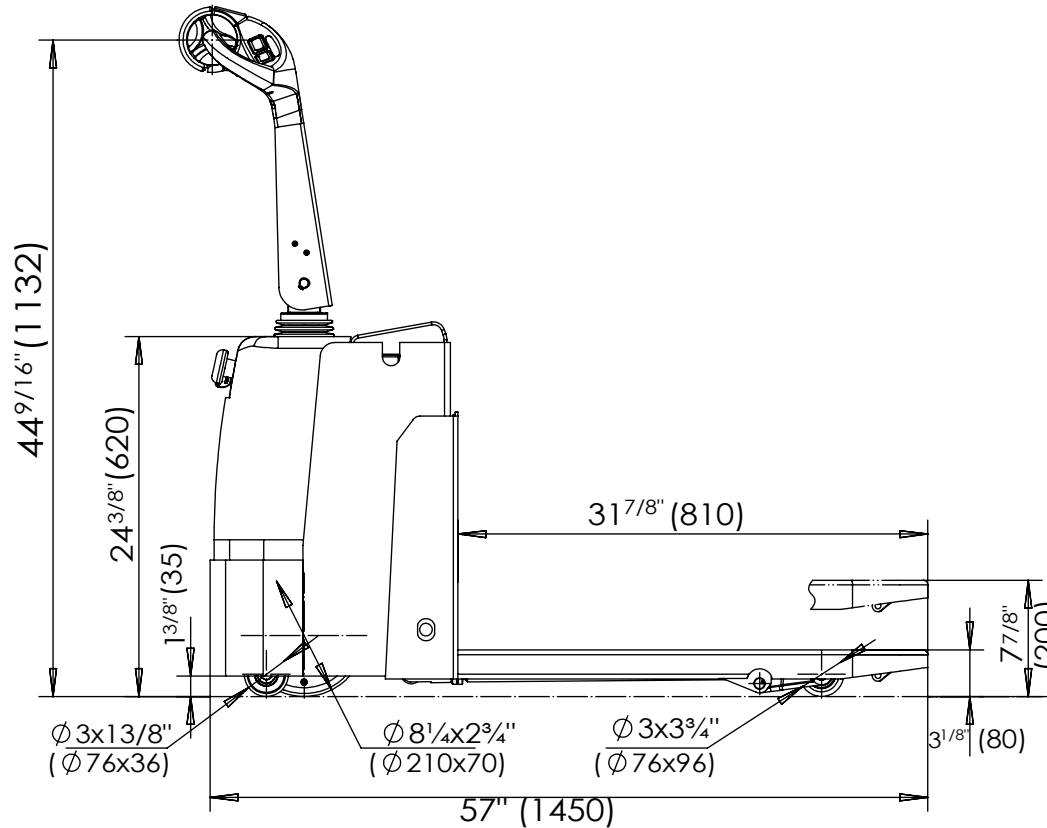

## SPECIFICATIONS

MODEL NUMBER: EPT-SF-1232-26  
 LOADING CAPACITY: 2,600 lbs (1,300 kgs)  
 DRIVE MOTOR: DC 24V / 0.5 KW  
 LIFT MOTOR: DC 24V / 0.7 KW  
 CONTROLLER: 1212-2501  
 HANDLE: CH-2  
 BATTERY: 2x 12V / 55Ah  
 BATTERY CHARGER: 24V / 10Amp  
 LIFTING SPEED W/O LOAD: 1.57" / sec  
 LIFTING SPEED W/ LOAD: 1.37" / sec  
 DOWN SPEED W/O LOAD: 1.18" / sec  
 DOWN SPEED W/ LOAD: 1.57" / sec  
 TRAVEL SPEED W/O LOAD: 2.7 M/H  
 TRAVEL SPEED W/ LOAD: 1.8 M/H  
 GRADEABILITY W/O LOAD: 6°  
 GRADEABILITY W/ LOAD: 5°  
 FORKS LOWERED HEIGHT: 3 1/8"  
 FORKS RAISED HEIGHT: 7 7/8"

DIMENSION TOLERANCE ± 1/2"

APPROVAL

I, THE UNDERSIGNED, AGREE THAT THE PRODUCT AS REPRESENTED SATISFIES DESIGN AND DIMENSION REQUIREMENTS. I ALSO ACKNOWLEDGE MY DUTY TO CONFIRM PRODUCT AND INSTALLATION COMPLIANCE WITH ALL APPLICABLE FEDERAL, STATE AND LOCAL REGULATIONS AND STANDARDS.

**UNITS REQUIRING APPROVAL DRAWINGS OR MODIFIED ARE NON-RETURNABLE**

[ ] As drawn [ ] As marked

Signed: \_\_\_\_\_ Date: \_\_\_\_\_

Printed Name: \_\_\_\_\_

LEAD TIME WILL START UPON RECEIPT OF SIGNED APPROVAL DRAWING

DISTRIBUTOR'S NAME:		P.O.#
VESTIL MANUFACTURING		X
DRAWN BY: TM		W.O.#
DATE: 09/07/2021		X
REFERENCE: X	SCALE: NTS	SALES: X
QUOTED LEAD TIME: X	QUOTE #	FILE NAME:
	X	EPT-SF-1232-26