

(SELF-ELEVATING SPRING TABLE) - ETS-230

APPROX WEIGHT: 149.74 lbs.
DOES NOT INCLUDE WEIGHT OF POWER OR PACKAGING!!!

ANY ADDITIONS, DELETIONS, OR OMISSIONS MUST BE CORRECTED ON THIS DRAWING AS THIS DRAWING WILL BE CONSIDERED ALL INCLUSIVE

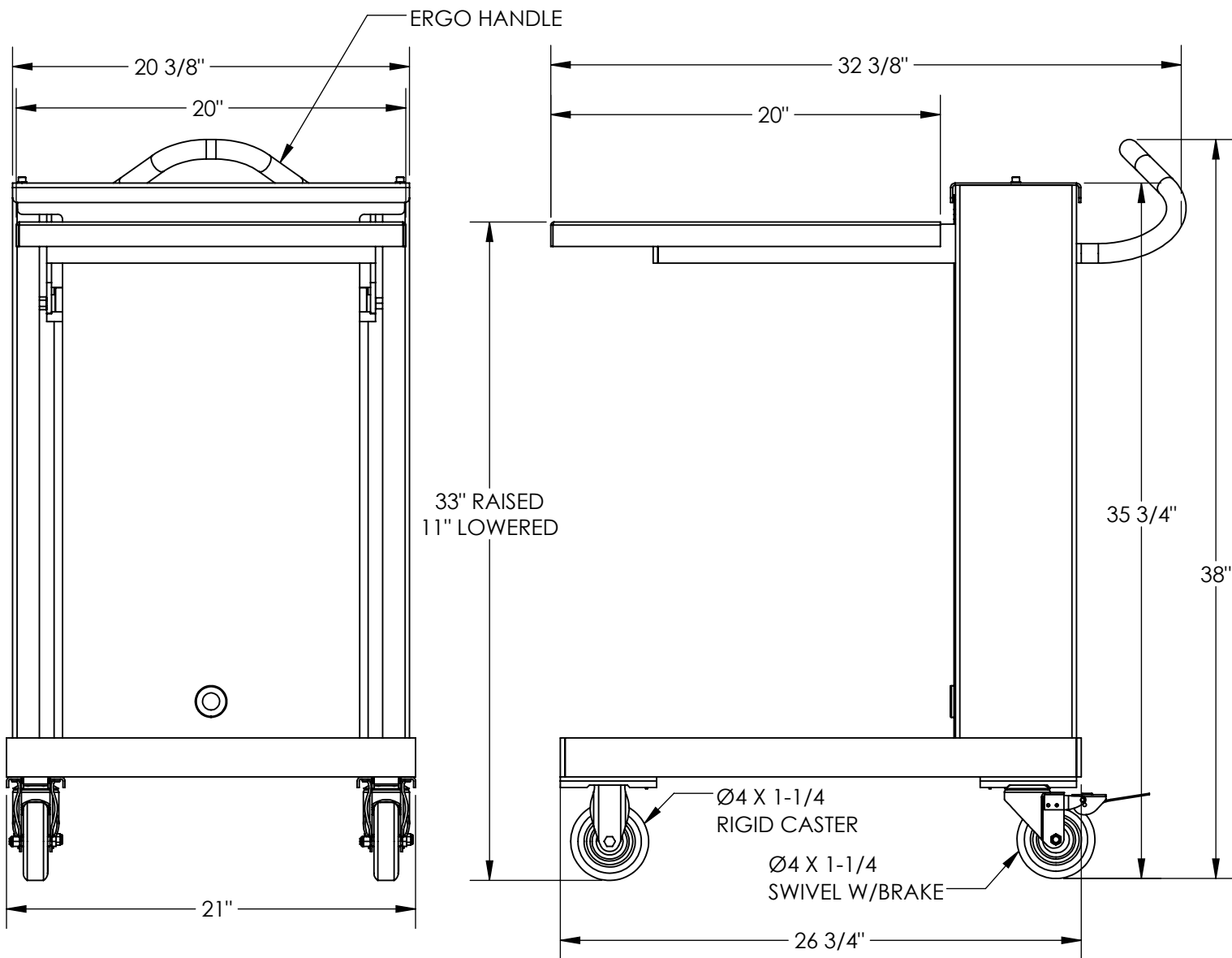

ALL GRAPHICS PROVIDED ARE FOR REFERENCE ONLY. IF CERTAIN DIMENSIONS ARE CRITICAL PLEASE VERIFY THOSE DIMENSIONS WITH YOUR SALESPERSON

STANDARD FEATURES

DIMENSION TOLERANCE ± 1/4"

- MODEL NUMBER IS ETS-230
- CAPACITY IS 230 LBS
- OVERALL WIDTH IS 21"
- USABLE PLATFORM WIDTH IS 20"
- OVERALL LENGTH IS 32 3/8"
- OVERALL HEIGHT IS 38"
- PLATFORM RAISED HEIGHT: 33"
- PLATFORM LOWERED HEIGHT: 11"
- NUMBER OF SPRINGS: 8 (NOT SHOWN)
- SPRING RATE IS 12 LBS PER INCH TOTAL FOR ALL 8 SPRINGS
- CASTER: (2) Ø4 X 1 1/4 POLY-ON-POLY RIGID
- (2) Ø4 X 1 1/4 POLY-ON-POLY SWIVEL W/BRAKE
- DURABLE LIQUID PAINT BLUE FINISH

SPECIAL FEATURES

NONE

A P P R O V A L	I, THE UNDERSIGNED, AGREE THAT THE PRODUCT AS REPRESENTED SATISFIES DESIGN AND DIMENSION REQUIREMENTS. I ALSO ACKNOWLEDGE MY DUTY TO CONFIRM PRODUCT AND INSTALLATION COMPLIANCE WITH ALL APPLICABLE FEDERAL, STATE AND LOCAL REGULATIONS AND STANDARDS.	
	UNITS REQUIRING APPROVAL DRAWINGS OR MODIFIED ARE NON-RETURNABLE	
	<input type="checkbox"/> As drawn	<input type="checkbox"/> As marked
	Signed: _____	Date: _____
	Printed Name: _____	
	LEAD TIME WILL START UPON RECEIPT OF SIGNED APPROVAL DRAWING	

DISTRIBUTOR'S NAME:		P.O.#
VESTIL MANUFACTURING		X
		W.O.#
DRAWN BY: RLH		X
DATE: 8/27/18		SALES:
REFERENCE: X		FILE NAME:
SCALE: 1:8		21-007-100
QUOTED LEAD TIME: X	QUOTE #	
	X	