

FIBERGLASS DOCKPLATE - FGDP-4824-1000

DOES NOT INCLUDE WEIGHT OF POWER OR PACKAGING!!!

*** ANY ADDITIONS, DELETIONS, OR OMISSIONS MUST BE CORRECTED ON THIS DRAWING AS THIS DRAWING WILL BE CONSIDERED ALL INCLUSIVE ***

ALL GRAPHICS PROVIDED ARE FOR REFERENCE ONLY. IF CERTAIN DIMENSIONS ARE CRITICAL PLEASE VERIFY THOSE DIMENSIONS WITH YOUR SALESPERSON

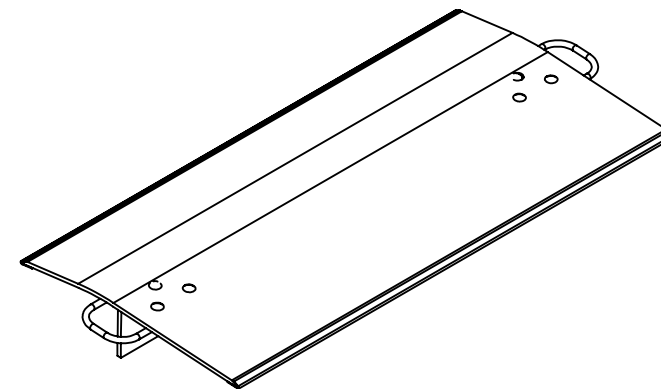
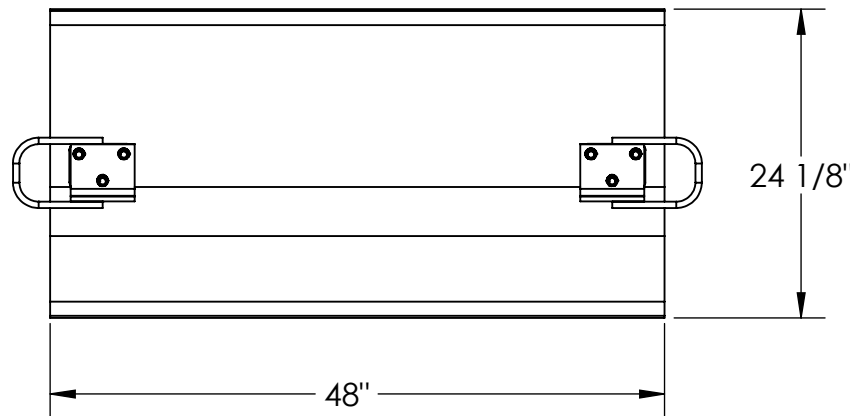
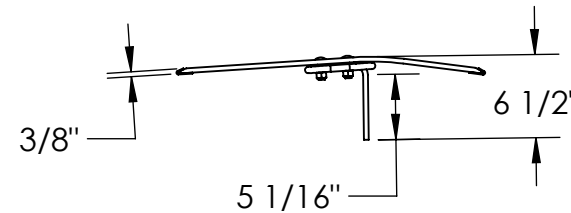
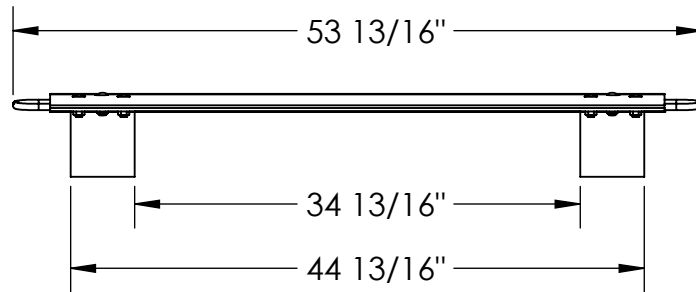

DIMENSION TOLERANCE $\pm 1/4$ "

STANDARD FEATURES

- MODEL NUMBER IS FGDP-4824-1000
- CAPACITY IS 1000 LBS
- OVERALL WIDTH IS 53 13/16"
- DECK WIDTH IS 48"
- OVERALL LENGTH IS 24 1/8"
- OVERALL HEIGHT IS 6 1/2"
- THICKNESS IS 3/8"
- HEIGHT DIFFERENTIAL IS 3"
- YELLOW ANTI-SKID FIBERGLASS PLATE
- APPROX. WEIGHT IS 39 LBS.

SPECIAL FEATURES

NONE

APPROVAL

I, THE UNDERSIGNED, AGREE THAT THE PRODUCT AS REPRESENTED SATISFIES DESIGN AND DIMENSION REQUIREMENTS. I ALSO ACKNOWLEDGE MY DUTY TO CONFIRM PRODUCT AND INSTALLATION COMPLIANCE WITH ALL APPLICABLE FEDERAL, STATE AND LOCAL REGULATIONS AND STANDARDS.

UNITS REQUIRING APPROVAL DRAWINGS OR MODIFIED ARE NON-RETURNABLE

As drawn As marked

Signed: _____ Date: _____

Printed Name: _____

LEAD TIME WILL START UPON RECEIPT OF SIGNED APPROVAL DRAWING

DISTRIBUTOR'S NAME:		P.O.#
VESTIL MANUFACTURING		X
DRAWN BY: C.CLEMENS		W.O.#
DATE: 5/24/19		X
REFERENCE: X	SCALE: 1:50	SALES: X
QUOTED LEAD TIME: X	QUOTE #	FILE NAME:
	X	12-007-117