

SAFETY CURB - FSC-38-96-YL

APPROX WEIGHT: 76.87 lbs.
 DOES NOT INCLUDE WEIGHT OF POWER OR PACKAGING!!!

*** ANY ADDITIONS, DELETIONS, OR OMISSIONS MUST BE CORRECTED ON THIS DRAWING AS THIS DRAWING WILL BE CONSIDERED ALL INCLUSIVE ***

ALL GRAPHICS PROVIDED ARE FOR REFERENCE ONLY. IF CERTAIN DIMENSIONS ARE CRITICAL PLEASE VERIFY THOSE DIMENSIONS WITH YOUR SALESPERSON

Ø 9/16" HOLES - 6-PLACES
 FOR LAG SCREWS
 (SCREWS NOT INCLUDED)

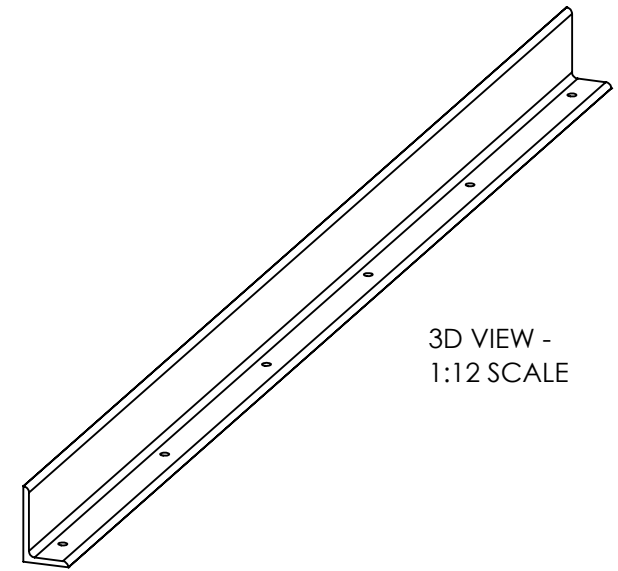
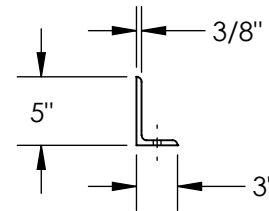
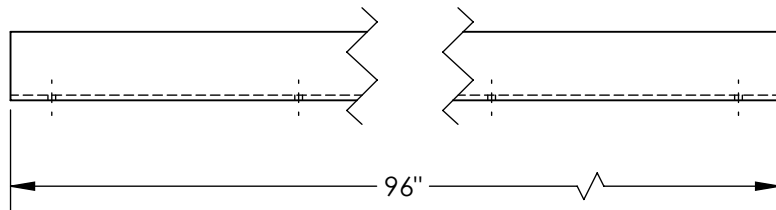
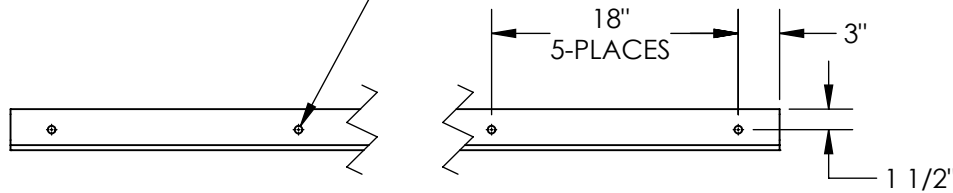

3D VIEW -
 1:12 SCALE

DIMENSION TOLERANCE ± 1/4"

STANDARD FEATURES

- MODEL NUMBER IS FSC-38-96-YL
- OVERALL WIDTH IS 3"
- OVERALL LENGTH IS 96"
- OVERALL HEIGHT IS 5"
- ANGLE LEG THICKNESS IS 3/8"
- ALL STEEL CONSTRUCTION FOR STRENGTH
- TOUGH BAKED IN POWDER COATED YELLOW FINISH

SPECIAL FEATURES

NONE

APPROVAL

I, THE UNDERSIGNED, AGREE THAT THE PRODUCT AS REPRESENTED SATISFIES DESIGN AND DIMENSION REQUIREMENTS. I ALSO ACKNOWLEDGE MY DUTY TO CONFIRM PRODUCT AND INSTALLATION COMPLIANCE WITH ALL APPLICABLE FEDERAL, STATE AND LOCAL REGULATIONS AND STANDARDS.

UNITS REQUIRING APPROVAL DRAWINGS OR MODIFIED ARE NON-RETURNABLE

As drawn As marked

Signed: _____ Date: _____

Printed Name: _____

LEAD TIME WILL START UPON RECEIPT OF SIGNED APPROVAL DRAWING

DISTRIBUTOR'S NAME:		P.O.#
VESTIL MANUFACTURING		X
DRAWN BY: M.SHOAFF		DATE: 7/11/2023
REFERENCE: X		SCALE: 1:14
QUOTED LEAD TIME: X	QUOTE #	FILE NAME:
	X	29-007-355