

HYDRAULIC BOX DUMPERS - HBD-2-36

APPROX WEIGHT: 1621.91 lbs.
 DOES NOT INCLUDE WEIGHT OF POWER OR PACKAGING!!!

*** ANY ADDITIONS, DELETIONS, OR OMISSIONS MUST BE CORRECTED ON THIS DRAWING AS THIS DRAWING WILL BE CONSIDERED ALL INCLUSIVE ***

ALL GRAPHICS PROVIDED ARE FOR REFERENCE ONLY. IF CERTAIN DIMENSIONS ARE CRITICAL PLEASE VERIFY THOSE DIMENSIONS WITH YOUR SALESPERSON

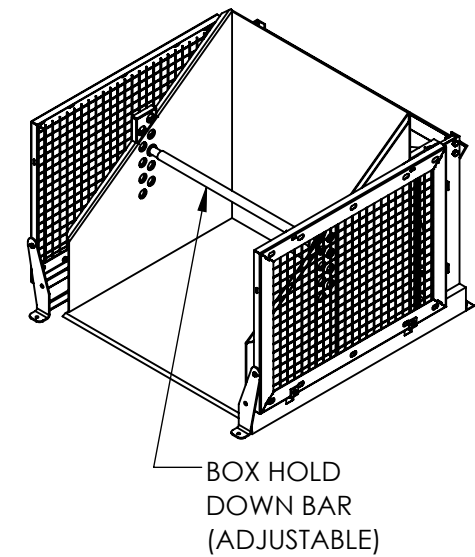
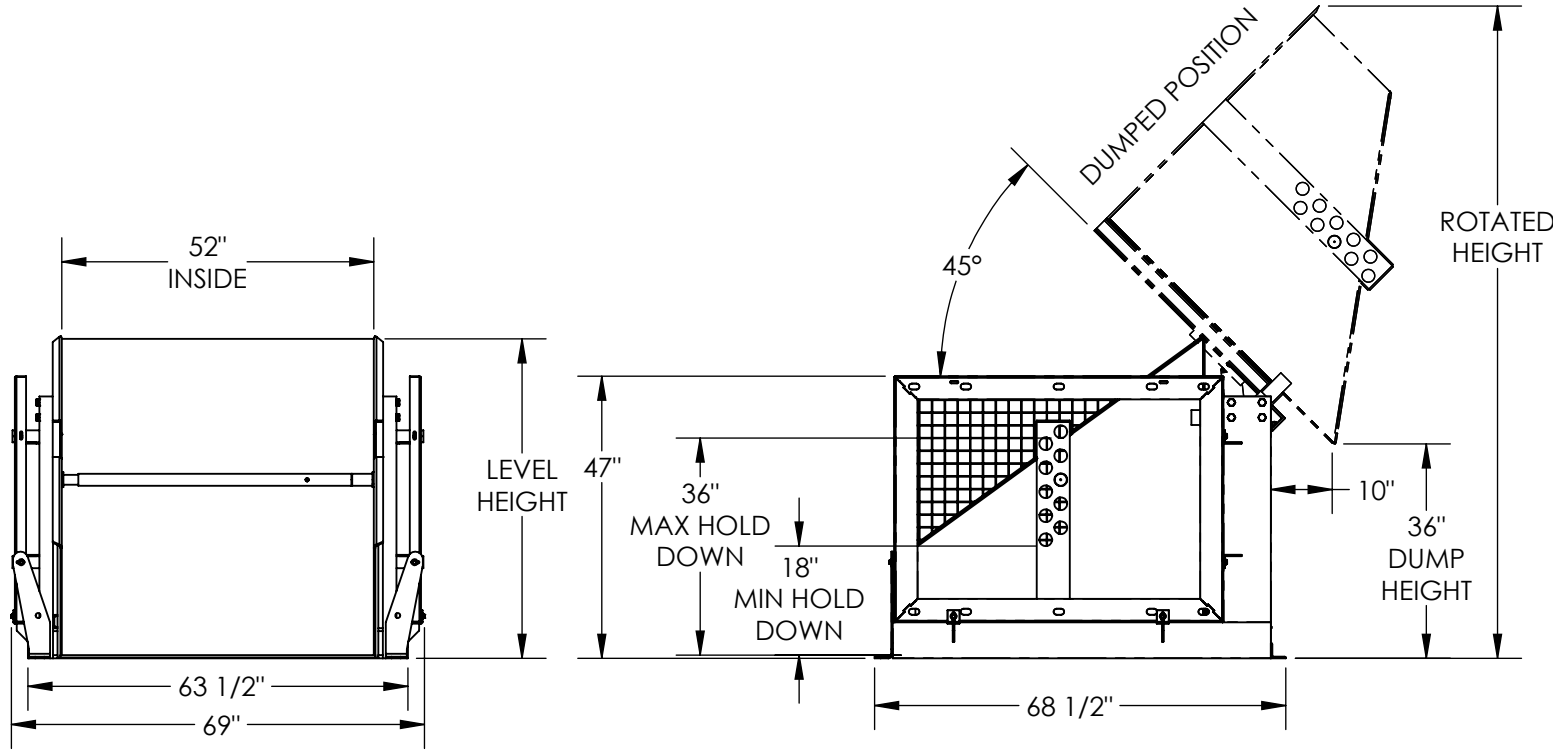

**460V 3 PHASE
 AC POWER**

CONTACT FACTORY FOR
 OTHER POWER OPTIONS

NOTE: SINGLE PH. PLUG-IN UNITS WILL HAVE
 APPROX 120 SEC DUMP / 33 SEC LOWER

STANDARD FEATURES

- HYDRAULIC BOX DUMPER MODEL IS HBD-2-36
- CHUTE IS 52" W X 50"L (USABLE)
- DUMPER CAPACITY IS 2000 LBS.
- DUMP HEIGHT IS 36"
- HOLD DOWN WILL ACCEPT BOXES 18" TO 36" HIGH W/ HOLES EVERY 2"
- FRAME WIDTH IS 69"
- FRAME LENGTH IS 68 1/2"
- LEVEL HEIGHT IS 53 1/2"
- ROTATED HEIGHT IS 111"
- DUMP ANGLE IS 45°
- CHROME PLATED CYLINDER WITH EMERGENCY STOP VELOCITY FUSE
- WARNING: CHECK STATE AND LOCAL CODES!!
- HANDHELD PUSH BUTTON CONTROL W/ 8ft EXTENDED COIL CORD
- FRAME & CHUTE DURABLE LIQUID PAINT BLUE FINISH
- GUARDS & HOLD DOWN BAR DURABLE BAKED IN POWDER COAT YELLOW FINISH

SPECIAL FEATURES

NONE

A P P R O V A L

I, THE UNDERSIGNED, AGREE THAT THE PRODUCT AS REPRESENTED SATISFIES DESIGN AND DIMENSION REQUIREMENTS. I ALSO ACKNOWLEDGE MY DUTY TO CONFIRM PRODUCT AND INSTALLATION COMPLIANCE WITH ALL APPLICABLE FEDERAL, STATE AND LOCAL REGULATIONS AND STANDARDS.
UNITS REQUIRING APPROVAL DRAWINGS OR MODIFIED ARE NON-RETURNABLE
 As drawn As marked

Signed: _____ Date: _____
 Printed Name: _____

LEAD TIME WILL START UPON RECEIPT OF SIGNED APPROVAL DRAWING

DISTRIBUTOR'S NAME:		P.O.#
VESTIL MANUFACTURING		X
DRAWN BY: CA		W.O.#
DATE: 09/22/2011		X
REFERENCE: X	SCALE: 1:32	SALES: X
QUOTED LEAD TIME: X	QUOTE #	FILE NAME:
	X	34-007-004

DIMENSION TOLERANCE ± 1/4"