

# HYDRAULIC BOX DUMPER - HBD-6-60

APPROX WEIGHT: 2101.81 lbs.  
 DOES NOT INCLUDE WEIGHT OF POWER OR PACKAGING!!!

\*\*\* ANY ADDITIONS, DELETIONS, OR OMISSIONS MUST BE CORRECTED ON THIS DRAWING AS THIS DRAWING WILL BE CONSIDERED ALL INCLUSIVE \*\*\*

ALL GRAPHICS PROVIDED ARE FOR REFERENCE ONLY. IF CERTAIN DIMENSIONS ARE CRITICAL PLEASE VERIFY THOSE DIMENSIONS WITH YOUR SALESPERSON

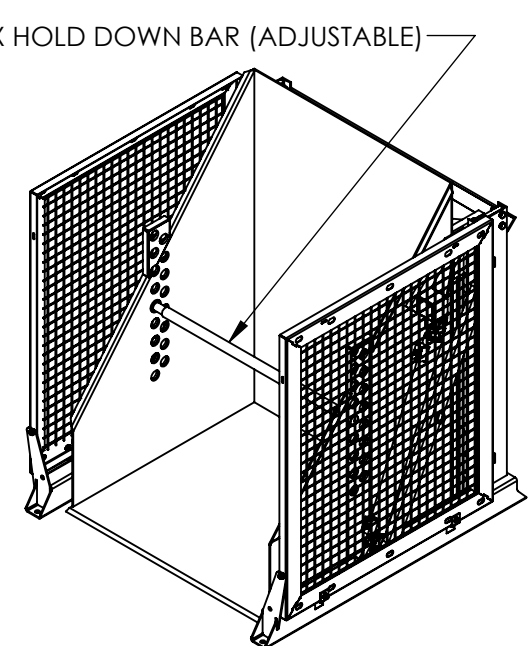
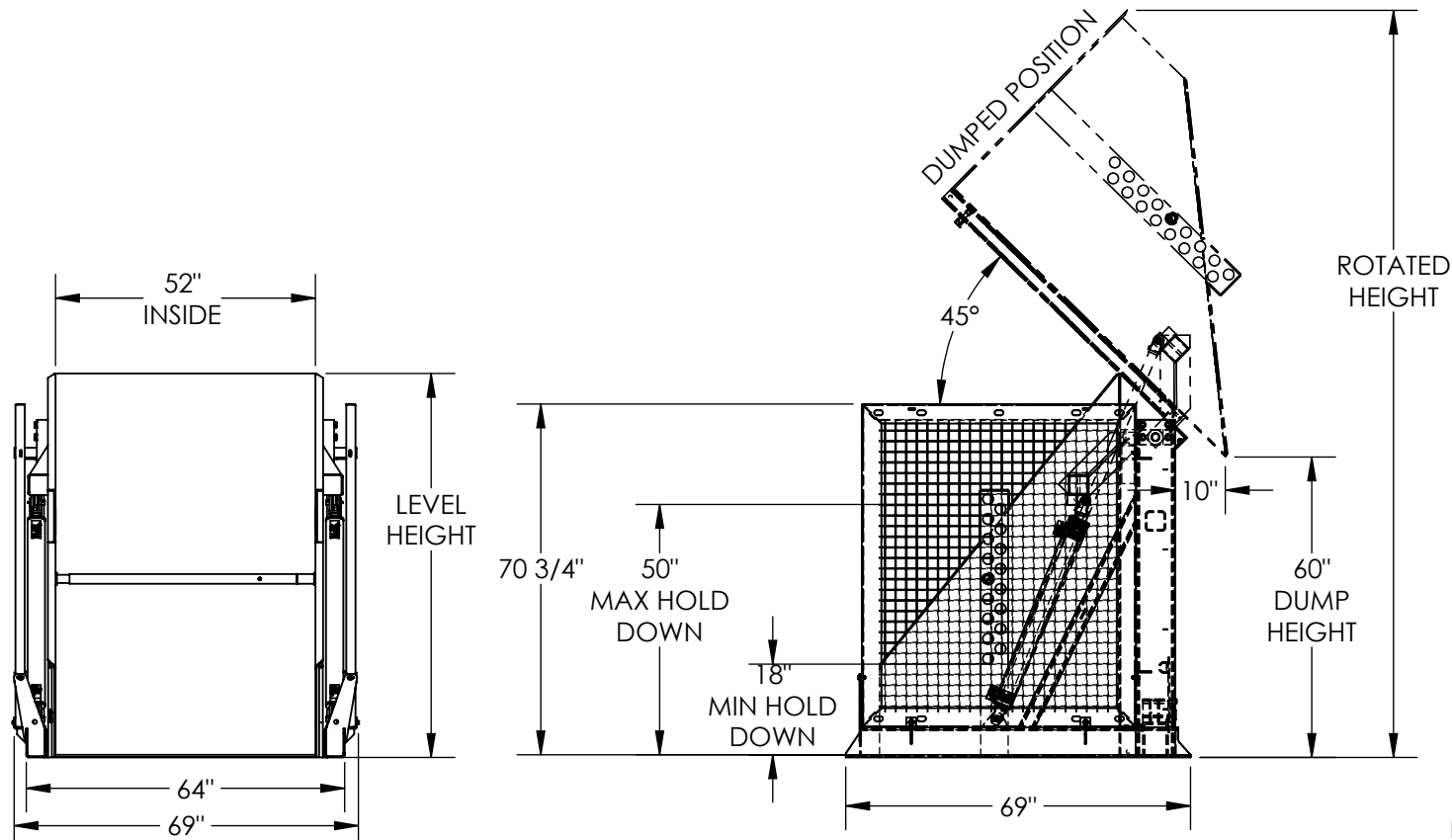

**460V 3 PHASE  
 AC POWER**

CONTACT FACTORY FOR  
 OTHER POWER OPTIONS

**NOTE:**  
 SINGLE PHASE EXCEEDS 5 MIN.  
 CYCLE TIME, 460 VOLT 3 PHASE RECOMMENDED,  
 CONTACT FACTORY FOR SINGLE PH APPLICATIONS

## STANDARD FEATURES

- HYDRAULIC BOX DUMPER MODEL IS HBD-6-60
- CHUTE IS 52" W X 50" L (USABLE)
- DUMPER CAPACITY IS 6000 LBS.
- DUMP HEIGHT IS 60"
- HOLD DOWN WILL ACCEPT BOXES 18" TO 50" HIGH W/ HOLES EVERY 2"
- FRAME WIDTH IS 69"
- FRAME LENGTH IS 69"
- LEVEL HEIGHT IS 77"
- ROTATED HEIGHT IS 149 1/2"
- DUMP ANGLE IS 45°
- CHROME PLATED CYLINDER WITH EMERGENCY STOP VELOCITY FUSE
- WARNING: CHECK STATE AND LOCAL CODES!!
- HANDHELD PUSH BUTTON CONTROL W/ 8ft EXTENDED COIL CORD
- FRAME & CHUTE ARE DURABLE LIQUID PAINT BLUE FINISH
- GUARDS & HOLD DOWN BAR ARE DURABLE BAKED IN POWDER COATED YELLOW FINISH

## SPECIAL FEATURES

NONE

**APPROVAL**

I, THE UNDERSIGNED, AGREE THAT THE PRODUCT AS REPRESENTED SATISFIES DESIGN AND DIMENSION REQUIREMENTS. I ALSO ACKNOWLEDGE MY DUTY TO CONFIRM PRODUCT AND INSTALLATION COMPLIANCE WITH ALL APPLICABLE FEDERAL, STATE AND LOCAL REGULATIONS, AND STANDARDS.

**UNITS REQUIRING APPROVAL DRAWINGS OR MODIFIED ARE NON-RETURNABLE**

As drawn       As marked

Signed: \_\_\_\_\_ Date: \_\_\_\_\_

Printed Name: \_\_\_\_\_

*LEAD TIME WILL START UPON RECEIPT OF SIGNED APPROVAL DRAWING*

DIMENSION TOLERANCE ± 1/4"

DISTRIBUTOR'S NAME:		P.O.#
VESTIL MANUFACTURING		X
DRAWN BY: CA		W.O.#
DATE: 10/26/2011		X
REFERENCE: X	SCALE: 1:38	SALES: X
QUOTED LEAD TIME: X	QUOTE #	FILE NAME:
	X	34-007-012