

HIGH PROFILE MACHINERY GUARD- HPRO-48-42-2

APPROX WEIGHT: 27.40 lbs.
DOES NOT INCLUDE WEIGHT OF POWER OR PACKAGING!!!

*** ANY ADDITIONS, DELETIONS, OR OMISSIONS MUST BE CORRECTED ON THIS DRAWING AS THIS DRAWING WILL BE CONSIDERED ALL INCLUSIVE ***

ALL GRAPHICS PROVIDED ARE FOR REFERENCE ONLY. IF CERTAIN DIMENSIONS ARE CRITICAL PLEASE VERIFY THOSE DIMENSIONS WITH YOUR SALESPERSON

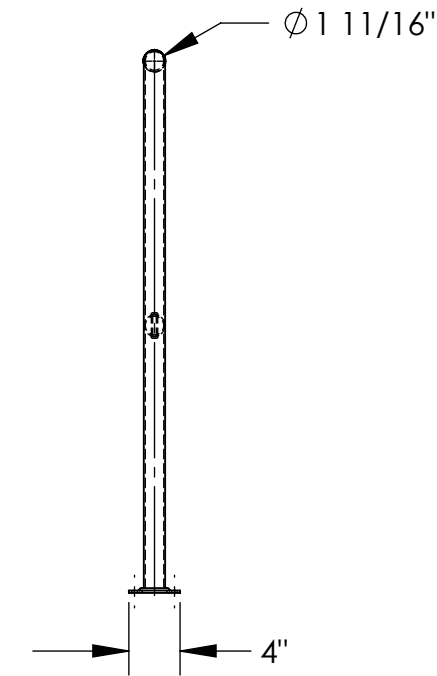
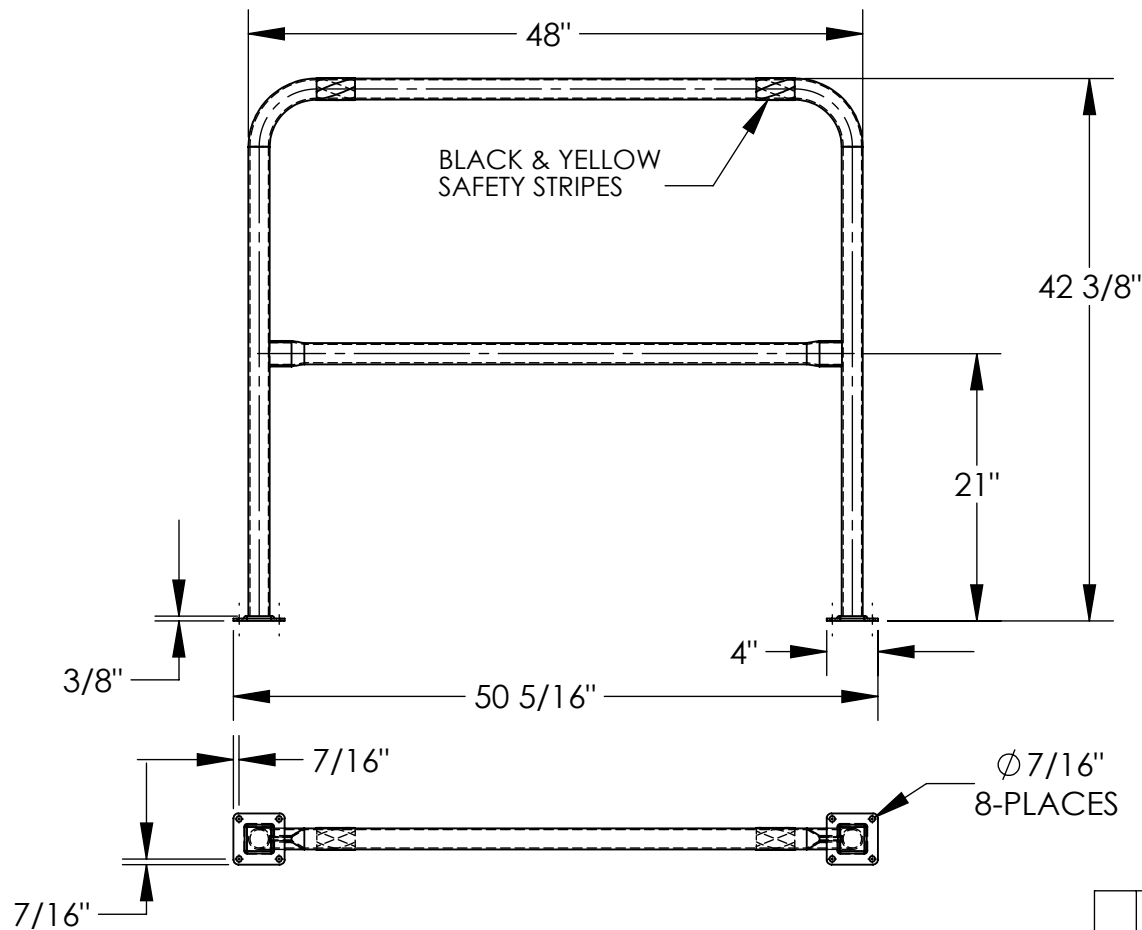

DIMENSION TOLERANCE ± 1/4"

I, THE UNDERSIGNED, AGREE THAT THE PRODUCT AS REPRESENTED SATISFIES DESIGN AND DIMENSION REQUIREMENTS. I ALSO ACKNOWLEDGE MY DUTY TO CONFIRM PRODUCT AND INSTALLATION COMPLIANCE WITH ALL APPLICABLE FEDERAL, STATE AND LOCAL REGULATIONS AND STANDARDS.

ANY MODIFIED UNITS ARE NON-RETURNABLE

As drawn As marked

Signed: _____ Date: _____

Printed Name: _____

LEAD TIME WILL START UPON RECEIPT OF SIGNED APPROVAL DRAWING

**A
P
P
R
O
V
A
L**

DISTRIBUTOR'S NAME: _____ P.O.# _____

VESTIL MANUFACTURING

W.O.# _____

DRAWN BY: ND

DATE: 11/15/07

SALES: X

REFERENCE: X

SCALE: 1:15

FILE NAME:

QUOTED LEAD TIME: X

QUOTE # X

23-007-199

SPECIAL FEATURES

NONE

STANDARD FEATURES

- MODEL NUMBER IS HPRO-48-42-2
- MACHINE GUARD HEIGHT: 42 3/8"
- MACHINE GUARD LENGTH: 48"
- MACHINE GUARD DIAMETER: 1 11/16"
- MIDRAIL HEIGHT: 21"
- OVERALL LENGTH: 50 5/16"
- INCLUDES 2 MOUNTING BRACKETS
- TOUGH BAKED IN POWDER COATED YELLOW FINISH
- BLACK AND YELLOW SAFETY STRIPES
- ALL STEEL CONSTRUCTION (ASTM A-36 MIN.) WITH WELDING TO MEET AWS
- WARNING: CHECK APPLICABLE STATE AND LOCAL LAWS FOR YOUR AREA

FOR INTERNAL USE ONLY
PROJECT SIGN OFF

SALES	
ENG.	
FAB.	
POWER	