

HIGH PROFILE MACHINERY GUARD - HPRO-48-42-4

APPROX WEIGHT: 80.22 lbs.
DOES NOT INCLUDE WEIGHT OF POWER OR PACKAGING!!!

*** ANY ADDITIONS, DELETIONS, OR OMISSIONS MUST BE CORRECTED ON THIS DRAWING AS THIS DRAWING WILL BE CONSIDERED ALL INCLUSIVE ***
ALL GRAPHICS PROVIDED ARE FOR REFERENCE ONLY. IF CERTAIN DIMENSIONS ARE CRITICAL PLEASE VERIFY THOSE DIMENSIONS WITH YOUR SALESPERSON

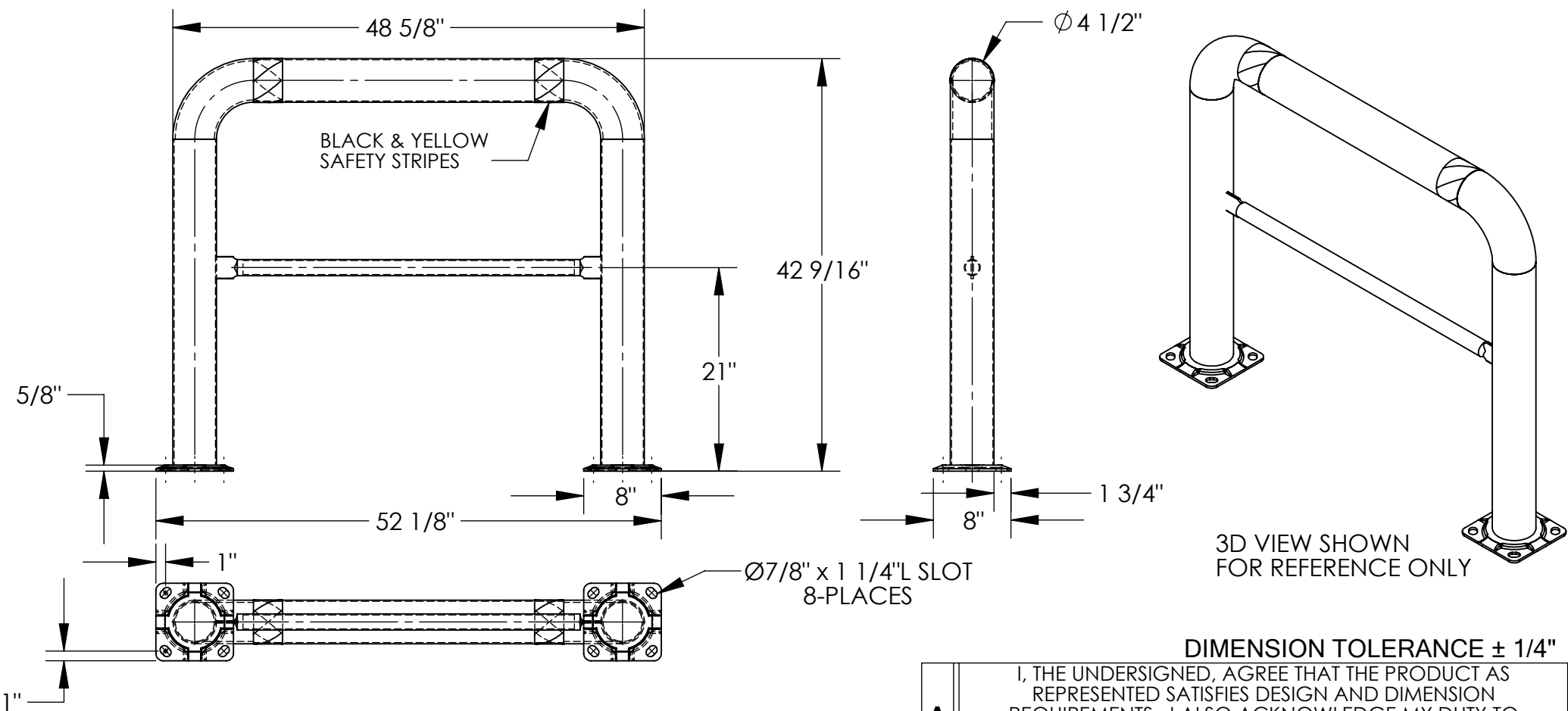

DIMENSION TOLERANCE $\pm 1/4$ "

STANDARD FEATURES

- MODEL NUMBER: HPRO-48-42-4
- MACHINE GUARD HEIGHT: 42 9/16"
- MACHINE GUARD LENGTH: 48 5/8"
- MACHINE GUARD MIDRAIL HEIGHT: 21"
- MACHINE GUARD DIAMETER: $\phi 4 \frac{1}{2}$ "
- OVERALL LENGTH: 52 1/8"
- INCLUDES 2 MOUNTING BRACKETS
- TOUGH BAKED IN POWDER COATED YELLOW FINISH
- BLACK AND YELLOW SAFETY STRIPES
- ALL STEEL CONSTRUCTION (ASTM A-36 MIN.) WITH WELDING TO MEET AWS
- WARNING: CHECK APPLICABLE STATE & LOCAL LAWS FOR YOUR AREA

SPECIAL FEATURES

NONE

APPROVAL

I, THE UNDERSIGNED, AGREE THAT THE PRODUCT AS REPRESENTED SATISFIES DESIGN AND DIMENSION REQUIREMENTS. I ALSO ACKNOWLEDGE MY DUTY TO CONFIRM PRODUCT AND INSTALLATION COMPLIANCE WITH ALL APPLICABLE FEDERAL, STATE AND LOCAL REGULATIONS AND STANDARDS.

ANY MODIFIED UNITS ARE NON-RETURNABLE

[] As drawn [] As marked

Signed: _____ Date: _____

Printed Name: _____

LEAD TIME WILL START UPON RECEIPT OF SIGNED APPROVAL DRAWING

FOR INTERNAL USE ONLY PROJECT SIGN OFF	
SALES	
ENG.	
FAB.	
POWER	

DISTRIBUTOR'S NAME:		P.O.#
VESTIL MANUFACTURING		X
W.O.#		X
DRAWN BY: ND	DATE: 6/7/2005	SALES: X
REFERENCE: X	SCALE: 1:15	FILE NAME:
QUOTED LEAD TIME: X	QUOTE # X	23-007-117