

HYDRAULIC POST TABLE - HT-02-24R

APPROX WEIGHT: 126 lbs.
 DOES NOT INCLUDE WEIGHT OF POWER OR PACKAGING!!!

*** ANY ADDITIONS, DELETIONS, OR OMISSIONS MUST BE CORRECTED ON THIS DRAWING AS THIS DRAWING WILL BE CONSIDERED ALL INCLUSIVE ***

ALL GRAPHICS PROVIDED ARE FOR REFERENCE ONLY. IF CERTAIN DIMENSIONS ARE CRITICAL PLEASE VERIFY THOSE DIMENSIONS WITH YOUR SALESPERSON

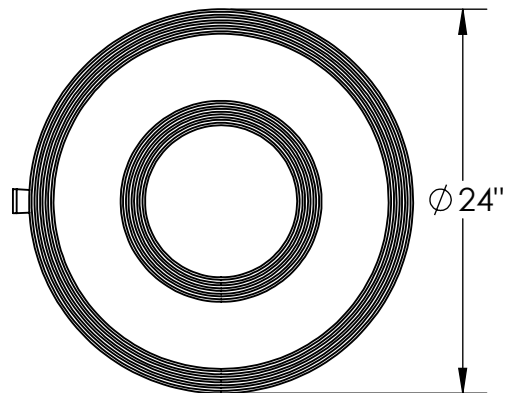

Ø 24"

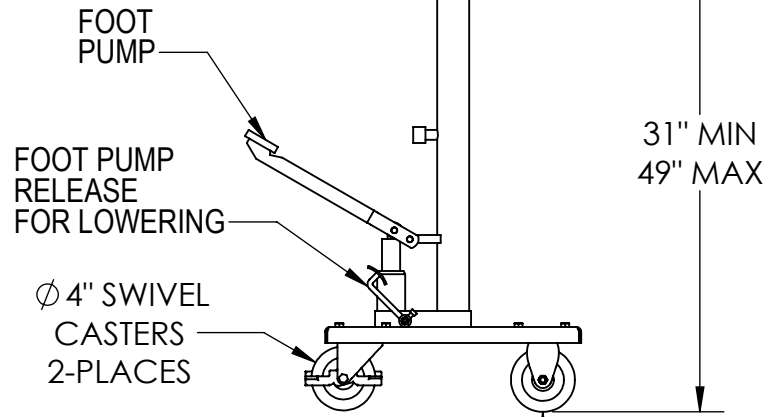

FOOT PUMP

FOOT PUMP RELEASE FOR LOWERING

Ø 4" SWIVEL CASTERS 2-PLACES

31" MIN
49" MAX

Ø 4" RIGID CASTERS 2-PLACES

STANDARD FEATURES

- MODEL NUMBER IS HT-02-24R
- MAX CAPACITY IS 200 LBS
- PLATFORM DIA. IS 24"
- SERVICE RANGE IS 31" MIN TO 49" MAX
- MANUAL FOOT PUMP OPERATION
- CASTERS
 - 2 RIGID - 4" DIA. X 1 1/4" WIDE
 - 2 SWIVEL W/BRAKE - 4" DIA. X 1 1/4" WIDE
- DURABLE LIQUID PAINT BLUE FINISH FRAME
- REMOVABLE RUBBER COVER ON STEEL PLATFORM

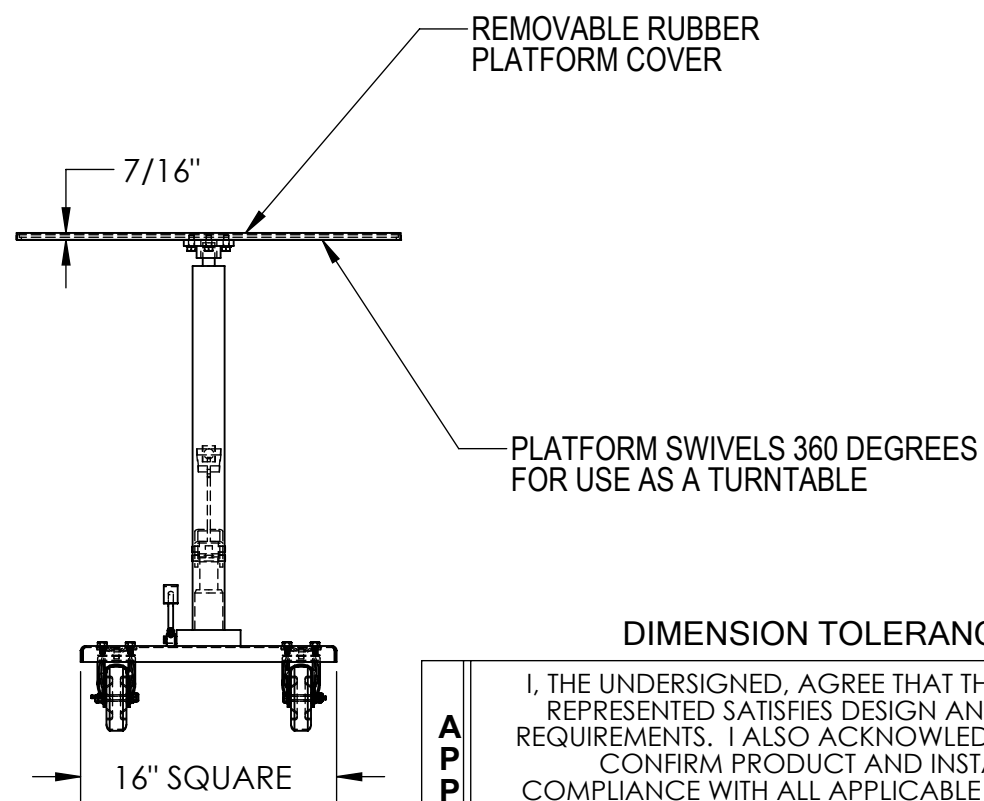

REMOVABLE RUBBER PLATFORM COVER

7/16"

PLATFORM SWIVELS 360 DEGREES FOR USE AS A TURNTABLE

16" SQUARE

SPECIAL FEATURES

NONE

DIMENSION TOLERANCE ± 1/4"

APPROVAL

I, THE UNDERSIGNED, AGREE THAT THE PRODUCT AS REPRESENTED SATISFIES DESIGN AND DIMENSION REQUIREMENTS. I ALSO ACKNOWLEDGE MY DUTY TO CONFIRM PRODUCT AND INSTALLATION COMPLIANCE WITH ALL APPLICABLE FEDERAL, STATE AND LOCAL REGULATIONS AND STANDARDS.

UNITS REQUIRING APPROVAL DRAWINGS OR MODIFIED ARE NON-RETURNABLE

As drawn As marked

Signed: _____ Date: _____

Printed Name: _____

LEAD TIME WILL START UPON RECEIPT OF SIGNED APPROVAL DRAWING

DISTRIBUTOR'S NAME:		P.O.#
VESTIL MANUFACTURING		X
DRAWN BY: MTS		DATE: 03/13/2024
REFERENCE: X		SALES: X
QUOTED LEAD TIME: X		SCALE: 1:12
QUOTE # X		FILE NAME: 21-007-201