

# HYDRAULIC POST TABLE - HT-20-4848

APPROX WEIGHT: 502.36 lbs.  
DOES NOT INCLUDE WEIGHT OF POWER OR PACKAGING!!!

\*\*\* ANY ADDITIONS, DELETIONS, OR OMISSIONS MUST BE CORRECTED ON THIS DRAWING AS THIS DRAWING WILL BE CONSIDERED ALL INCLUSIVE \*\*\*

ALL GRAPHICS PROVIDED ARE FOR REFERENCE ONLY. IF CERTAIN DIMENSIONS ARE CRITICAL PLEASE VERIFY THOSE DIMENSIONS WITH YOUR SALESPERSON

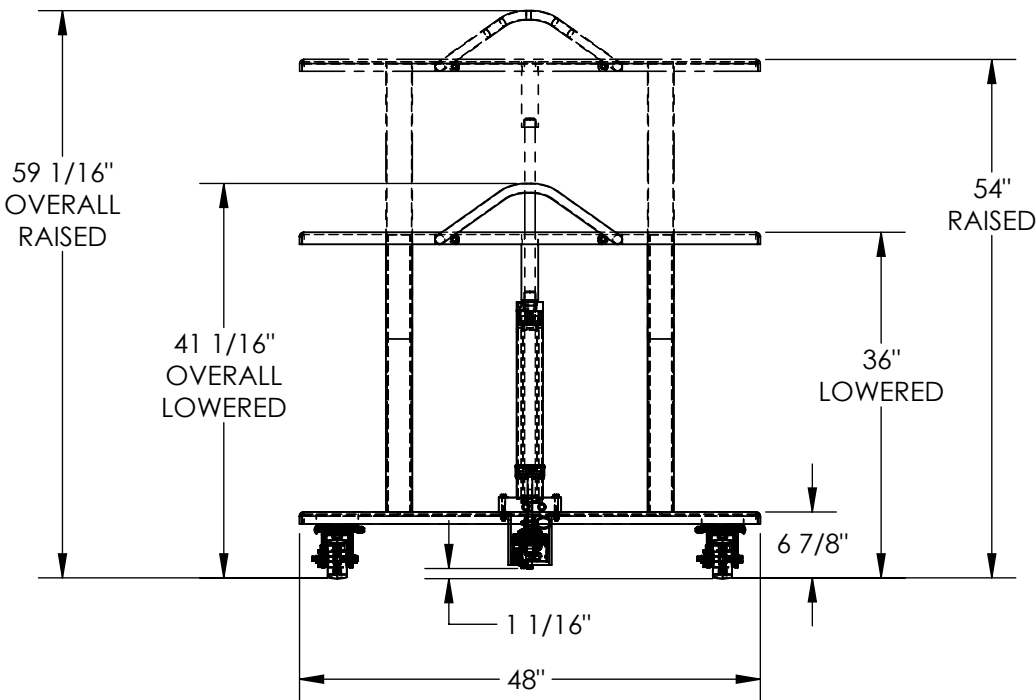
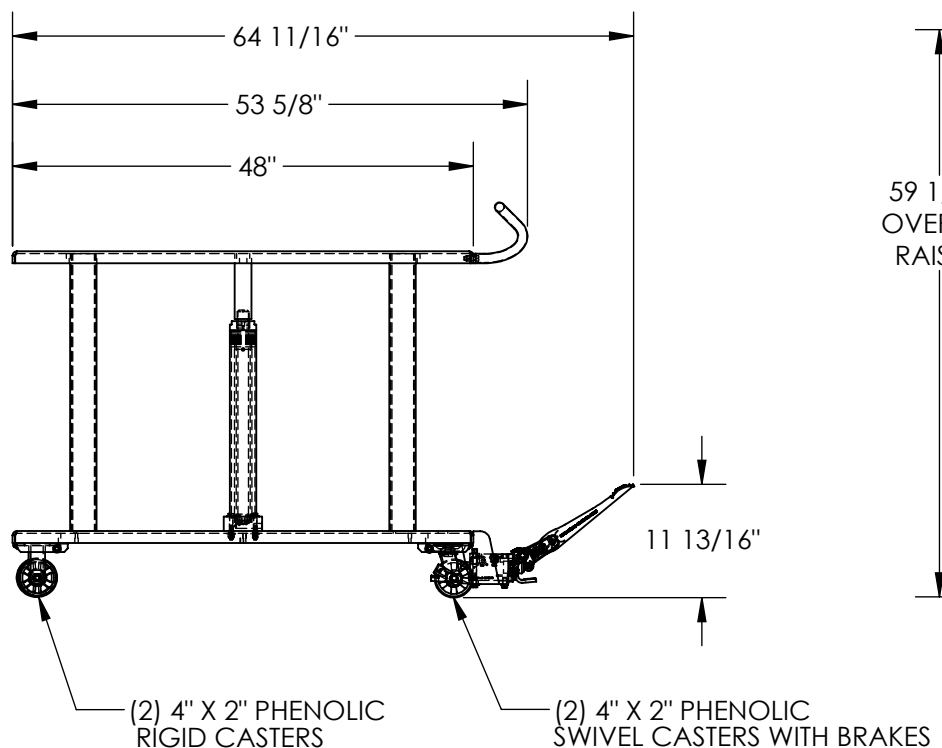

HYDRAULIC HOSES NOT SHOWN

## STANDARD FEATURES

- MODEL NUMBER IS HT-20-4848
- MAX CAPACITY IS 2,000 LBS.
- OVERALL WIDTH IS 48"
- USABLE WIDTH IS 48"
- OVERALL LENGTH IS 64 11/16"
- USABLE LENGTH IS 48"
- RAISED HEIGHT IS 54"
- LOWERED HEIGHT IS 36"
- OVERALL RAISED HEIGHT IS 59 1/16"
- OVERALL LOWERED HEIGHT IS 41 1/16"
- (2) PHENOLIC RIGID CASTERS
- (2) PHENOLIC SWIVEL CASTERS WITH BRAKES
- TOUGH BAKED IN POWDER COATED BLUE FINISH

## SPECIAL FEATURES

NONE

DIMENSION TOLERANCE  $\pm 1/4"$

I, THE UNDERSIGNED, AGREE THAT THE PRODUCT AS REPRESENTED SATISFIES DESIGN AND DIMENSION REQUIREMENTS. I ALSO ACKNOWLEDGE MY DUTY TO CONFIRM PRODUCT AND INSTALLATION COMPLIANCE WITH ALL APPLICABLE FEDERAL, STATE AND LOCAL REGULATIONS AND STANDARDS.

**UNITS REQUIRING APPROVAL DRAWINGS OR MODIFIED ARE NON-RETURNABLE**

[ ] As drawn [ ] As marked

Signed: \_\_\_\_\_ Date: \_\_\_\_\_

Printed Name: \_\_\_\_\_

LEAD TIME WILL START UPON RECEIPT OF SIGNED APPROVAL DRAWING

APPROVAL

DISTRIBUTOR'S NAME:		P.O.#
VESTIL MANUFACTURING		X
DRAWN BY: TAW		W.O.#
DATE: 5/25/2016		X
REFERENCE: X	SCALE: 1:20	SALES: X
QUOTED LEAD TIME: X	QUOTE #	FILE NAME:
	X	21-007-112