

HYDRAULIC POST TABLE - HT-40-2436-DC

APPROX WEIGHT: 469.56 lbs.
 DOES NOT INCLUDE WEIGHT OF POWER OR PACKAGING!!!

*** ANY ADDITIONS, DELETIONS, OR OMISSIONS MUST BE CORRECTED ON THIS DRAWING AS THIS DRAWING WILL BE CONSIDERED ALL INCLUSIVE ***

ALL GRAPHICS PROVIDED ARE FOR REFERENCE ONLY. IF CERTAIN DIMENSIONS ARE CRITICAL PLEASE VERIFY THOSE DIMENSIONS WITH YOUR SALESPERSON

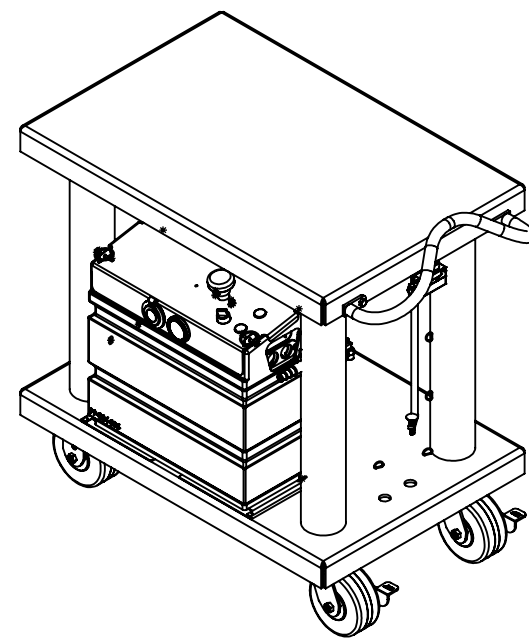
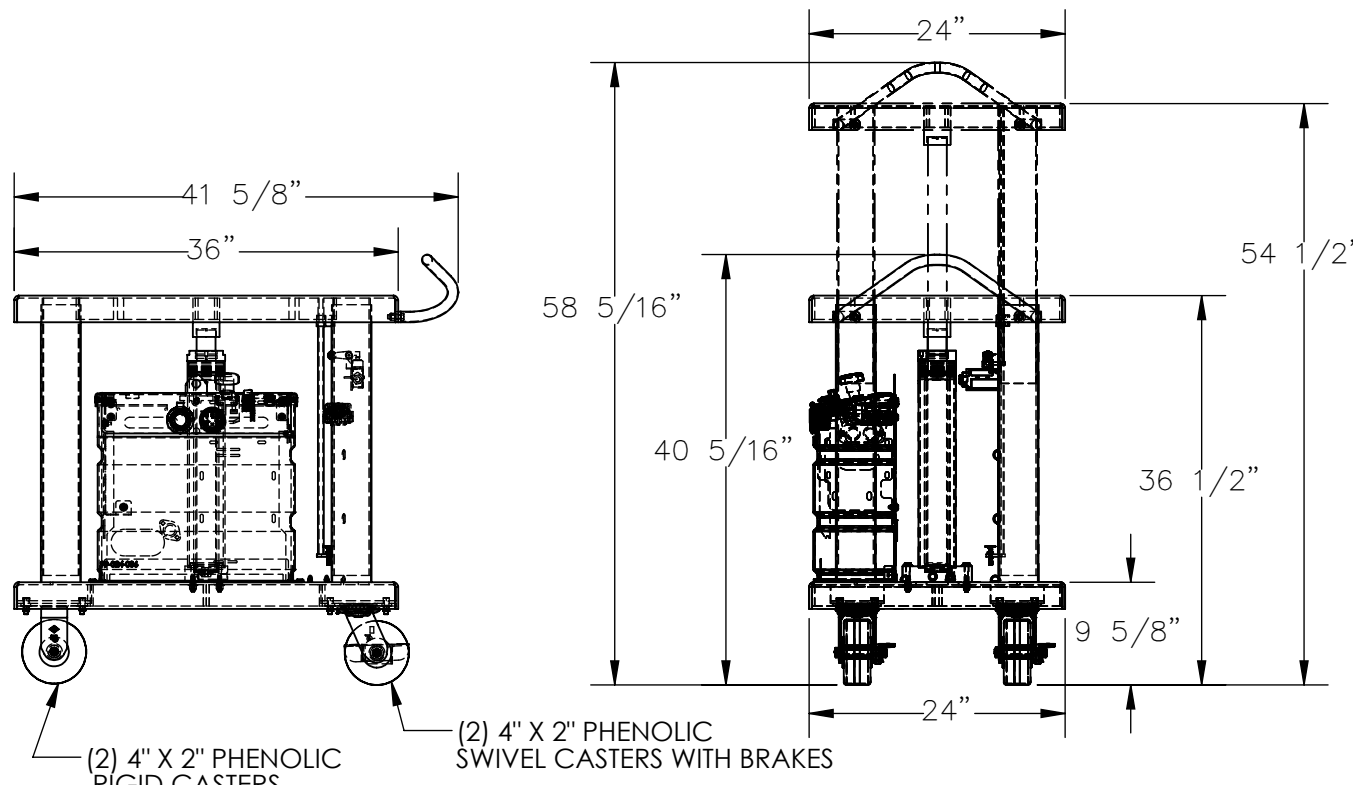

DIMENSION TOLERANCE ± 1/4"

STANDARD FEATURES

MODEL NUMBER IS HT-40-2436-DC
 MAX CAPACITY IS 4,000 LBS.
 OVERALL WIDTH: 24"
 USABLE WIDTH: 24"
 OVERALL LENGTH: 41 5/8"
 USABLE LENGTH: 36"
 RAISED HEIGHT: 54 1/2"
 LOWERED HEIGHT: 36 1/2"
 OVERALL RAISED HEIGHT: 58 5/16"
 OVERALL LOWERED HEIGHT: 40 5/16"
 (2) PHENOLIC RIGID CASTERS
 (2) PHENOLIC SWIVEL CASTERS WITH BRAKES
 HYDRAULIC HOSES NOT SHOWN
 TOUGH BAKED IN POWDER COATED BLUE FINISH

PLEASE CIRCLE SPECIFICATIONS:

POWER	<input type="checkbox"/> AC	<input checked="" type="checkbox"/> DC (12V)	<input type="checkbox"/> *AIR/OIL	
MOTOR VOLTAGE	<input type="checkbox"/> 115	<input type="checkbox"/> 208	<input type="checkbox"/> 230	<input type="checkbox"/> 460
DEDICATED CIRCUIT REQUIRED				
MOTOR PHASE	<input type="checkbox"/> SINGLE		<input type="checkbox"/> THREE	
CONTROL	<input checked="" type="checkbox"/> HAND	<input type="checkbox"/> * FOOT		
~ ALL BATTERY CHARGERS ARE 115V AC ~				
BATTERY CHRG.	<input type="checkbox"/> REMOTE	<input checked="" type="checkbox"/> ON-BOARD		
* CHRG. INDICATOR	<input type="checkbox"/> YES	<input type="checkbox"/> NO		

* AVAILABLE AT ADDITIONAL COST

SPECIAL FEATURES

NONE

A P P R O V A L

I, THE UNDERSIGNED, AGREE THAT THE PRODUCT AS REPRESENTED SATISFIES DESIGN AND DIMENSION REQUIREMENTS. I ALSO ACKNOWLEDGE MY DUTY TO CONFIRM PRODUCT AND INSTALLATION COMPLIANCE WITH ALL APPLICABLE FEDERAL, STATE AND LOCAL REGULATIONS AND STANDARDS.

UNITS REQUIRING APPROVAL DRAWINGS OR MODIFIED ARE NON-RETURNABLE

[] As drawn [] As marked

Signed: _____ Date: _____

Printed Name: _____

LEAD TIME WILL START UPON RECEIPT OF SIGNED APPROVAL DRAWING

DISTRIBUTOR'S NAME:		P.O.#
VESTIL MANUFACTURING		X
DRAWN BY: CRH	DATE: 3/11/2020	W.O.#
REFERENCE: X	SCALE: 1:18	X
QUOTED LEAD TIME: X	QUOTE #	SALES: X
	X	FILE NAME:
		21-007-148