

7-STEP ROLLING STEEL WAREHOUSE LADDER - LAD-7-14-P

APPROX WEIGHT: 190.6651 lbs.
 DOES NOT INCLUDE WEIGHT OF POWER OR PACKAGING!!!

*** ANY ADDITIONS, DELETIONS, OR OMISSIONS MUST BE CORRECTED ON THIS DRAWING AS THIS DRAWING WILL BE CONSIDERED ALL INCLUSIVE ***

ALL GRAPHICS PROVIDED ARE FOR REFERENCE ONLY. IF CERTAIN DIMENSIONS ARE CRITICAL PLEASE VERIFY THOSE DIMENSIONS WITH YOUR SALESPERSON

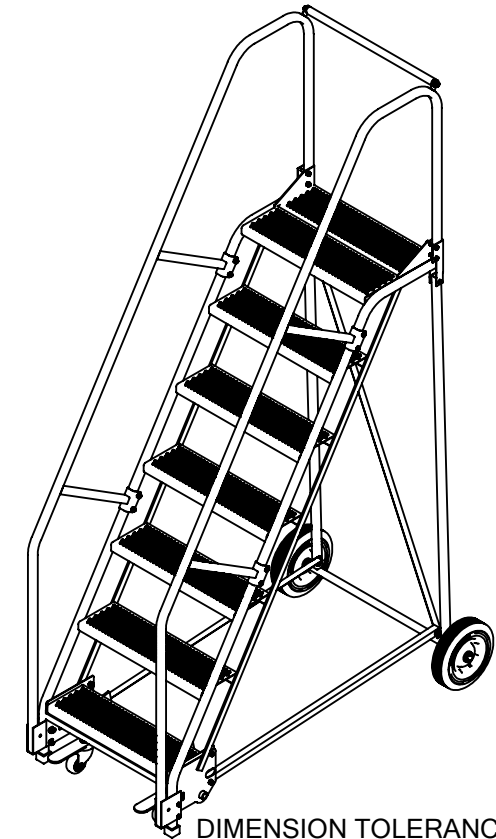
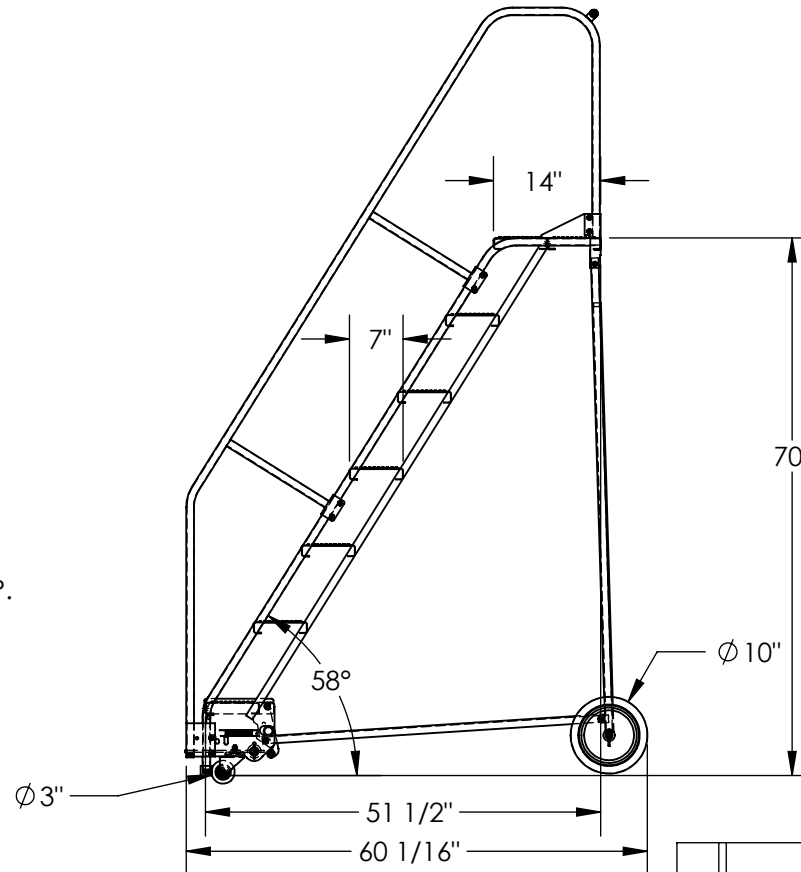
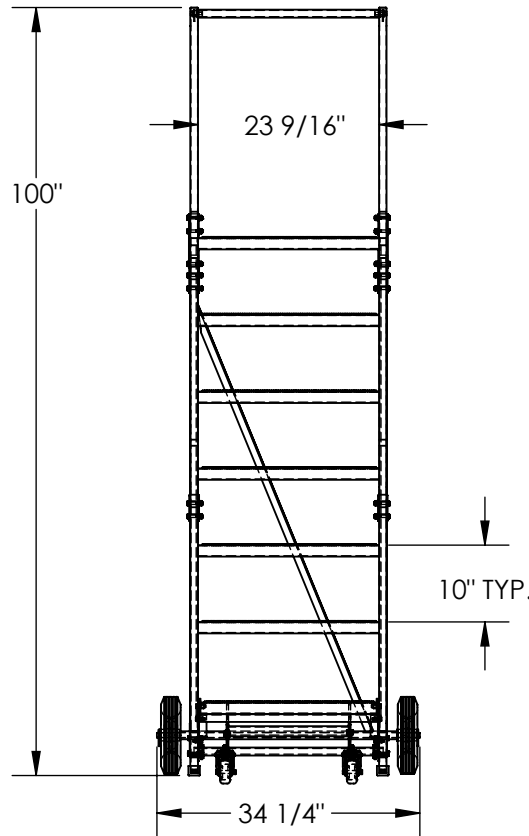

DIMENSION TOLERANCE ± 1/4"

STANDARD FEATURES

- MODEL NUMBER IS LAD-7-14-P
- OVERALL WIDTH IS 34 1/4"
- USABLE WIDTH IS 23 9/16"
- OVERALL LENGTH IS 60 1/16"
- USABLE LENGTH IS 51 1/2"
- OVERALL HEIGHT IS 100"
- TOP STEP HEIGHT IS 70"
- STEP TYPE IS PERFORATED
- CLIMB ANGLE IS 58°
- STEP DEPTH IS 7"
- TOP STEP DEPTH IS 14"
- MAX CAPACITY IS 350 LBS
- WHEEL SIZE IS Ø10"
- FRONT WHEEL SIZE IS Ø3"
- TOUGH BAKED IN POWDER COATED BLUE & YELLOW FINISH
- COLOR IS BLUE, BOTTOM STEP IS YELLOW

NOTE

- SOME ASSEMBLY REQUIRED
- TOOL TRAY SOLD SEPARATELY
- SAFETY GATE SOLD SEPARATELY

SPECIAL FEATURES

NONE

APPROVAL

I, THE UNDERSIGNED, AGREE THAT THE PRODUCT AS REPRESENTED SATISFIES DESIGN AND DIMENSION REQUIREMENTS. I ALSO ACKNOWLEDGE MY DUTY TO CONFIRM PRODUCT AND INSTALLATION COMPLIANCE WITH ALL APPLICABLE FEDERAL, STATE AND LOCAL REGULATIONS AND STANDARDS.
UNITS REQUIRING APPROVAL DRAWINGS OR MODIFIED ARE NON-RETURNABLE
 As drawn As marked

Signed: _____ Date: _____

LEAD TIME WILL START UPON RECEIPT OF SIGNED APPROVAL DRAWING

| | | |
|-----------------------|--|-----------------------|
| DISTRIBUTOR'S NAME: | | P.O.# |
| VESTIL MANUFACTURING | | X |
| DRAWN BY: B.NOTHNAGEL | | DATE: 9/22/2015 |
| REFERENCE: X | | SCALE: 1:25 |
| QUOTED LEAD TIME: X | | QUOTE # X |
| | | SALES: X |
| | | FILE NAME: 44-007-161 |