

8-STEP ROLLING STEEL WAREHOUSE LADDER 50° - LAD-8-14-G-EZ

APPROX WEIGHT: 215.5412 lbs.
DOES NOT INCLUDE WEIGHT OF POWER OR PACKAGING!!!

*** ANY ADDITIONS, DELETIONS, OR OMISSIONS MUST BE CORRECTED ON THIS DRAWING AS THIS DRAWING WILL BE CONSIDERED ALL INCLUSIVE ***
ALL GRAPHICS PROVIDED ARE FOR REFERENCE ONLY. IF CERTAIN DIMENSIONS ARE CRITICAL PLEASE VERIFY THOSE DIMENSIONS WITH YOUR SALESPERSON

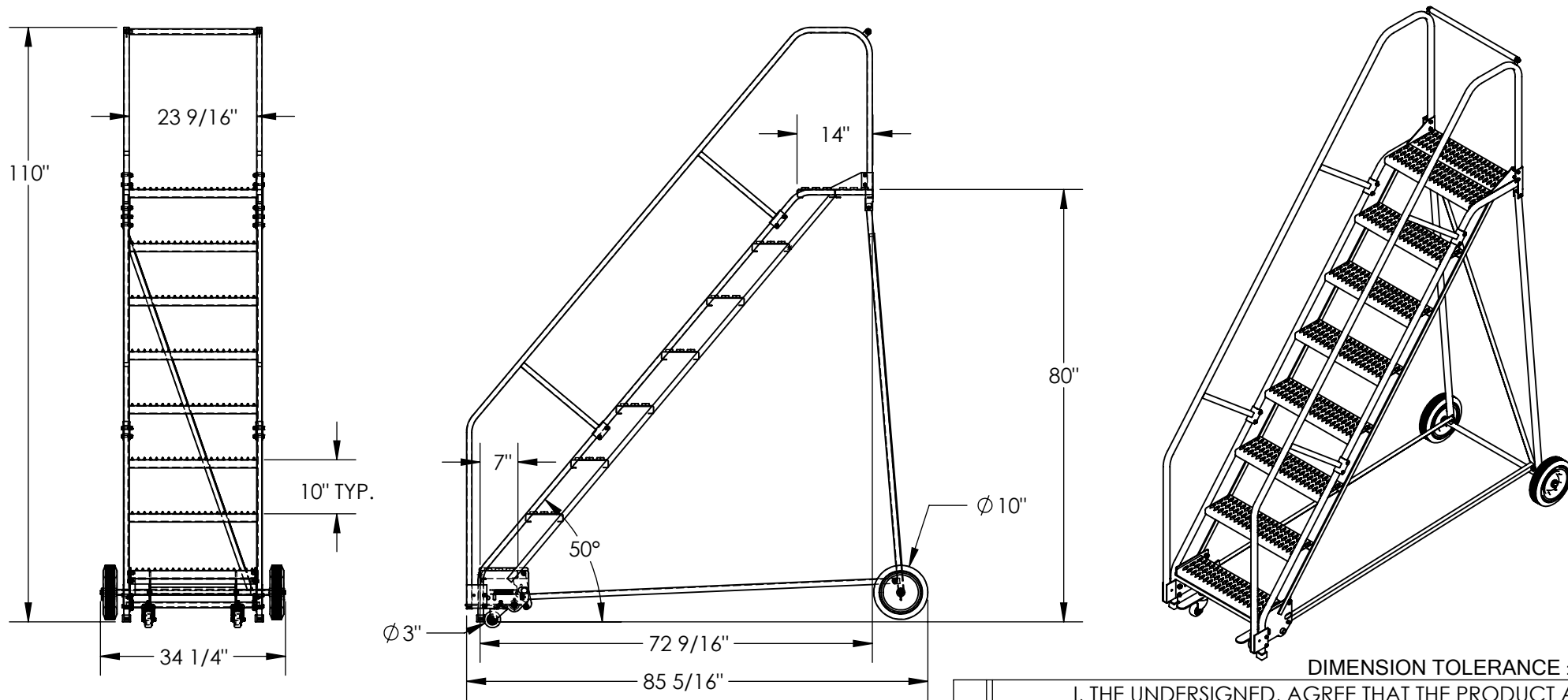

STANDARD FEATURES

- MODEL NUMBER IS LAD-8-14-G-EZ •
- OVERALL WIDTH IS 34 1/4" •
- USABLE WIDTH IS 23 9/16" •
- OVERALL LENGTH IS 85 5/16" •
- USABLE LENGTH IS 72 9/16" •
- OVERALL HEIGHT IS 110" •
- TOP STEP HEIGHT IS 80" •
- STEP TYPE IS GRIP STRUT •
- CLIMB ANGLE IS 50° •
- STEP DEPTH IS 7" •
- TOP STEP DEPTH IS 14" •
- MAX CAPACITY IS 350 LBS •
- WHEEL SIZE IS Ø10" •
- FRONT WHEEL SIZE IS Ø3" •
- TOUGH BAKED IN POWDER COATED BLUE FINISH •
- BOTTOM STEP IS TOUGH BAKED IN POWDER COATED YELLOW FINISH •

NOTE

- SOME ASSEMBLY REQUIRED •
- TOOL TRAY SOLD SEPARATELY •
- SAFETY GATE SOLD SEPARATELY •

SPECIAL FEATURES

NONE

DIMENSION TOLERANCE ± 1/4"

APPROVAL

I, THE UNDERSIGNED, AGREE THAT THE PRODUCT AS REPRESENTED SATISFIES DESIGN AND DIMENSION REQUIREMENTS. I ALSO ACKNOWLEDGE MY DUTY TO CONFIRM PRODUCT AND INSTALLATION COMPLIANCE WITH ALL APPLICABLE FEDERAL, STATE AND LOCAL REGULATIONS AND STANDARDS.
UNITS REQUIRING APPROVAL DRAWINGS OR MODIFIED ARE NON-RETURNABLE
[] As drawn [] As marked

Signed: _____ Date: _____

LEAD TIME WILL START UPON RECEIPT OF SIGNED APPROVAL DRAWING

DISTRIBUTOR'S NAME:		P.O.#
VESTIL MANUFACTURING		X
DRAWN BY: B.NOTHNAGEL		DATE: 9/23/2015
REFERENCE: X		SCALE: 1:28
QUOTED LEAD TIME: X		QUOTE # X
		SALES: X
		FILE NAME: 44-007-576