

# 8-STEP ROLLING STEEL WAREHOUSE LADDER 50° - LAD-8-21-G-EZ

APPROX WEIGHT: 226.8164 lbs.  
 DOES NOT INCLUDE WEIGHT OF POWER OR PACKAGING!!!

\*\*\* ANY ADDITIONS, DELETIONS, OR OMISSIONS MUST BE CORRECTED ON THIS DRAWING AS THIS DRAWING WILL BE CONSIDERED ALL INCLUSIVE \*\*\*  
 ALL GRAPHICS PROVIDED ARE FOR REFERENCE ONLY. IF CERTAIN DIMENSIONS ARE CRITICAL PLEASE VERIFY THOSE DIMENSIONS WITH YOUR SALESPERSON

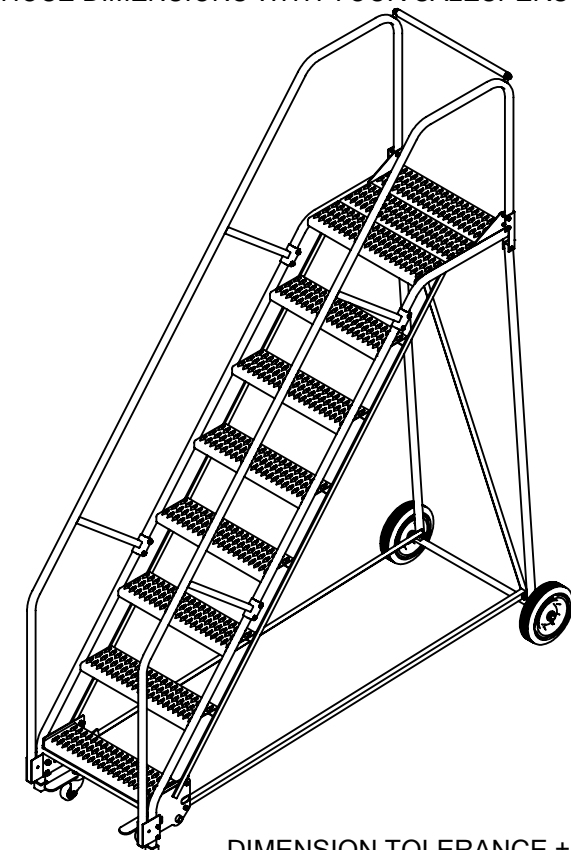
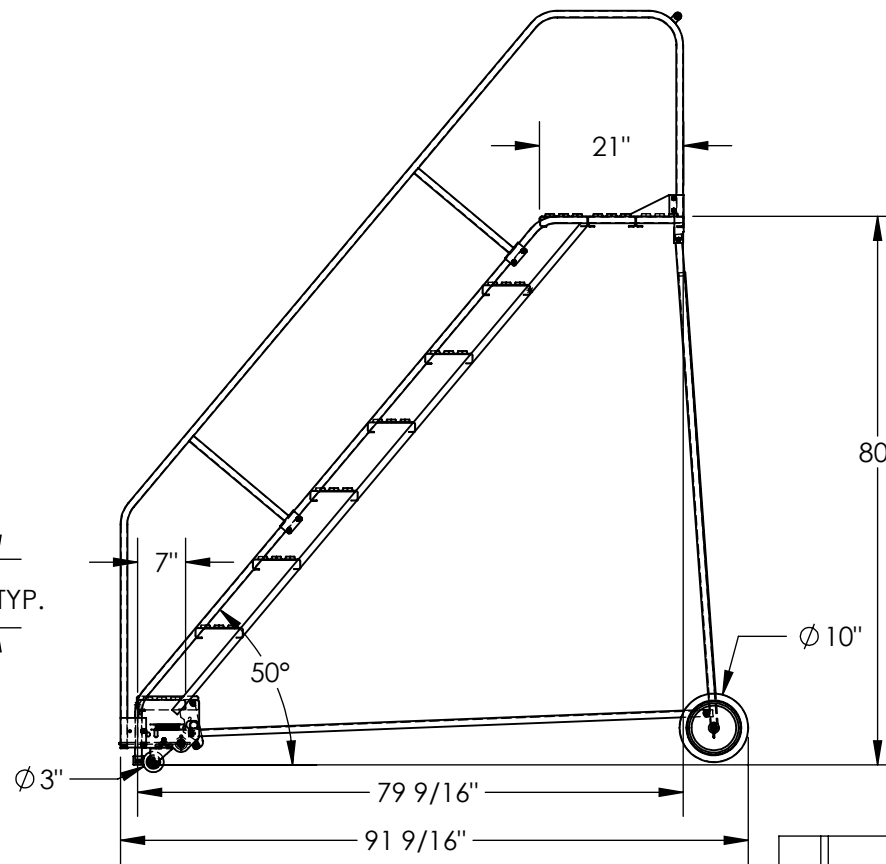
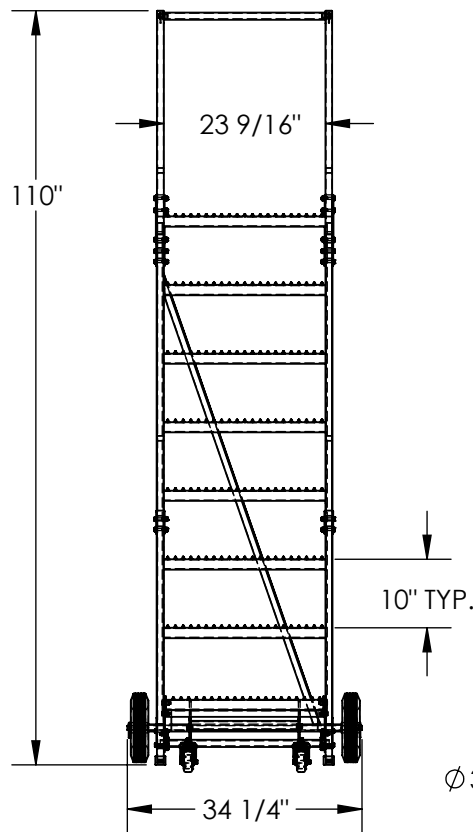

DIMENSION TOLERANCE ± 1/4"

## STANDARD FEATURES

- MODEL NUMBER IS LAD-8-21-G-EZ
- OVERALL WIDTH IS 34 1/4"
- USABLE WIDTH IS 23 9/16"
- OVERALL LENGTH IS 91 9/16"
- USABLE LENGTH IS 79 9/16"
- OVERALL HEIGHT IS 110"
- TOP STEP HEIGHT IS 80"
- STEP TYPE IS GRIP STRUT
- CLIMB ANGLE IS 50°
- STEP DEPTH IS 7"
- TOP STEP DEPTH IS 21"
- MAX CAPACITY IS 350 LBS
- WHEEL SIZE IS Ø10"
- FRONT WHEEL SIZE IS Ø3"
- TOUGH BAKED IN POWDER COATED BLUE FINISH
- BOTTOM STEP IS TOUGH BAKED IN POWDER COATED YELLOW FINISH

## NOTE

- SOME ASSEMBLY REQUIRED
- TOOL TRAY SOLD SEPARATELY
- SAFETY GATE SOLD SEPARATELY

## SPECIAL FEATURES

NONE

**UNITS REQUIRING APPROVAL DRAWINGS OR MODIFIED ARE NON-RETURNABLE**  
 As drawn       As marked

Signed: \_\_\_\_\_ Date: \_\_\_\_\_

LEAD TIME WILL START UPON RECEIPT OF SIGNED APPROVAL DRAWING

DISTRIBUTOR'S NAME:		P.O.#
VESTIL MANUFACTURING		X
DRAWN BY: B.NOTHNAGEL		DATE: 9/23/2015
REFERENCE: X		SCALE: 1:28
QUOTED LEAD TIME: X	QUOTE #	FILE NAME:
	X	44-007-578