

9-STEP ROLLING STEEL WAREHOUSE LADDER 50° - LAD-9-21-P-EZ

APPROX WEIGHT: 240.9478 lbs.
 DOES NOT INCLUDE WEIGHT OF POWER OR PACKAGING!!!

*** ANY ADDITIONS, DELETIONS, OR OMISSIONS MUST BE CORRECTED ON THIS DRAWING AS THIS DRAWING WILL BE CONSIDERED ALL INCLUSIVE ***

ALL GRAPHICS PROVIDED ARE FOR REFERENCE ONLY. IF CERTAIN DIMENSIONS ARE CRITICAL PLEASE VERIFY THOSE DIMENSIONS WITH YOUR SALESPERSON

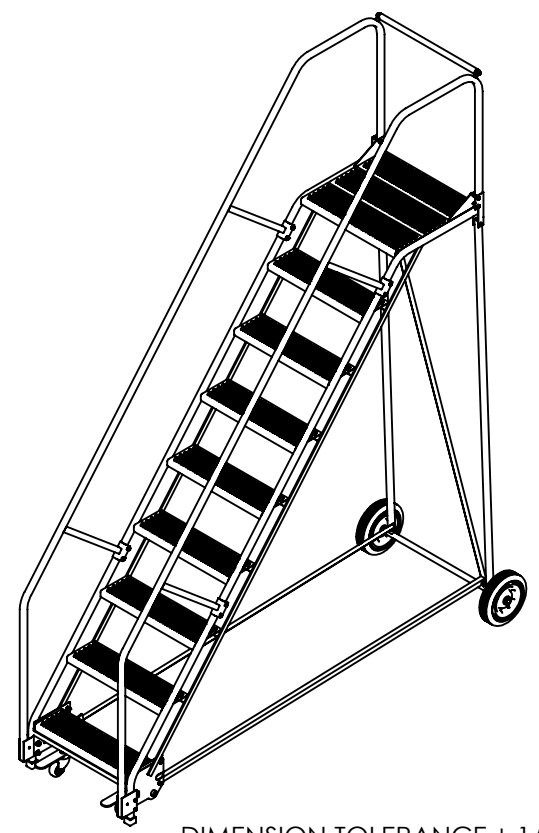
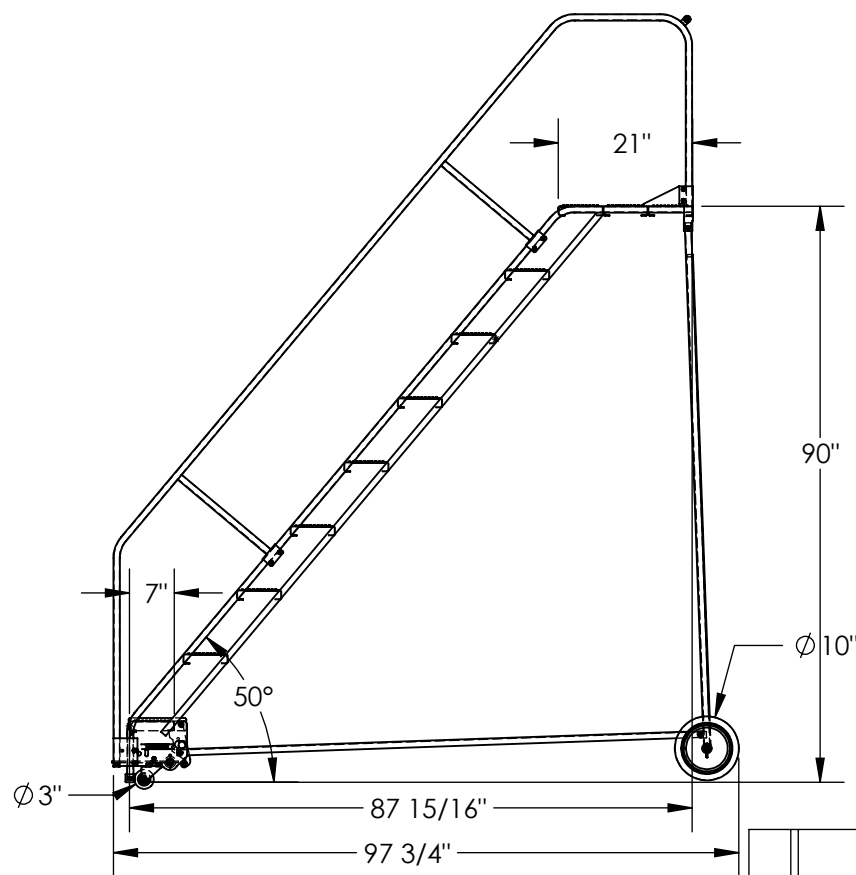
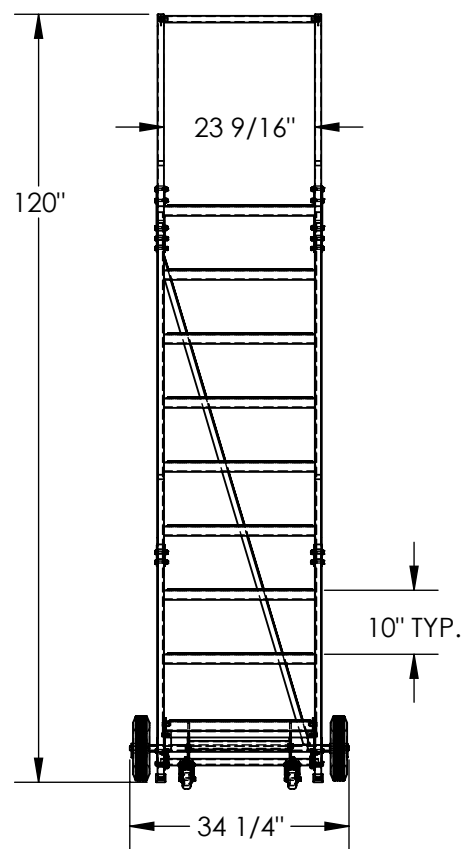

DIMENSION TOLERANCE ± 1/4"

STANDARD FEATURES

- MODEL NUMBER IS LAD-9-21-P-EZ
- OVERALL WIDTH IS 34 1/4"
- USABLE WIDTH IS 23 9/16"
- OVERALL LENGTH IS 97 3/4"
- USABLE LENGTH IS 87 15/16"
- OVERALL HEIGHT IS 120"
- TOP STEP HEIGHT IS 90"
- STEP TYPE IS PERFORATED
- CLIMB ANGLE IS 50°
- STEP DEPTH IS 7"
- TOP STEP DEPTH IS 21"
- MAX CAPACITY IS 350 LBS
- WHEEL SIZE IS Ø10"
- FRONT WHEEL SIZE IS Ø3"
- TOUGH BAKED IN POWDER COATED BLUE FINISH
- BOTTOM STEP IS TOUGH BAKED IN POWDER COATED YELLOW FINISH

NOTE

- SOME ASSEMBLY REQUIRED
- TOOL TRAY SOLD SEPARATELY
- SAFETY GATE SOLD SEPARATELY

SPECIAL FEATURES

NONE

APPROVAL

I, THE UNDERSIGNED, AGREE THAT THE PRODUCT AS REPRESENTED SATISFIES DESIGN AND DIMENSION REQUIREMENTS. I ALSO ACKNOWLEDGE MY DUTY TO CONFIRM PRODUCT AND INSTALLATION COMPLIANCE WITH ALL APPLICABLE FEDERAL, STATE AND LOCAL REGULATIONS AND STANDARDS.

UNITS REQUIRING APPROVAL DRAWINGS OR MODIFIED ARE NON-RETURNABLE

[] As drawn [] As marked

Signed: _____ Date: _____

LEAD TIME WILL START UPON RECEIPT OF SIGNED APPROVAL DRAWING

DISTRIBUTOR'S NAME:		P.O.#
VESTIL MANUFACTURING		X
DRAWN BY: B.NOTHNAGEL		DATE: 9/23/2015
REFERENCE: X		SCALE: 1:30
QUOTED LEAD TIME: X	QUOTE #	FILE NAME:
	X	44-007-547