

DOUBLE SIDED STEP LADDER, 4-STEP, GRIP STRUT - LAD-DD-18-4-G

APPROX WEIGHT: 86.46 lbs.
DOES NOT INCLUDE WEIGHT OF POWER OR PACKAGING!!!

*** ANY ADDITIONS, DELETIONS, OR OMISSIONS MUST BE CORRECTED ON THIS DRAWING AS THIS DRAWING WILL BE CONSIDERED ALL INCLUSIVE ***

ALL GRAPHICS PROVIDED ARE FOR REFERENCE ONLY. IF CERTAIN DIMENSIONS ARE CRITICAL PLEASE VERIFY THOSE DIMENSIONS WITH YOUR SALESPERSON

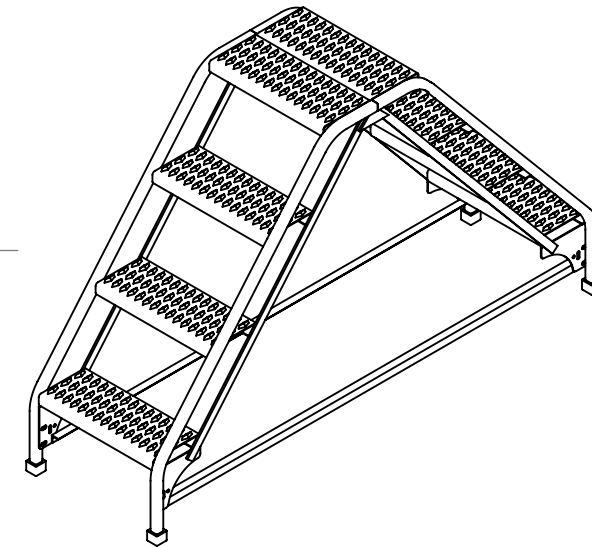
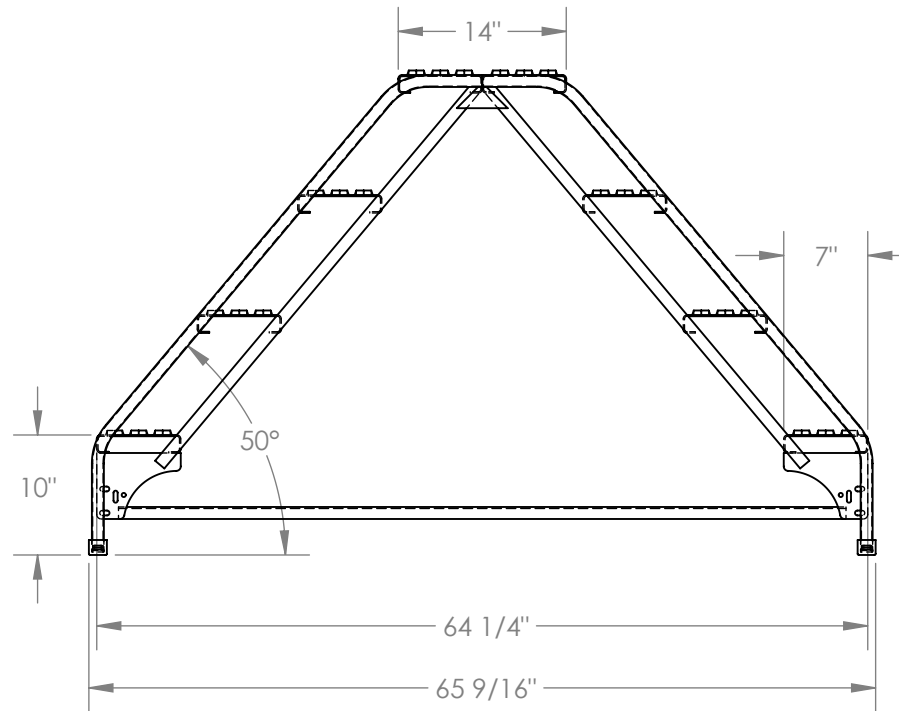
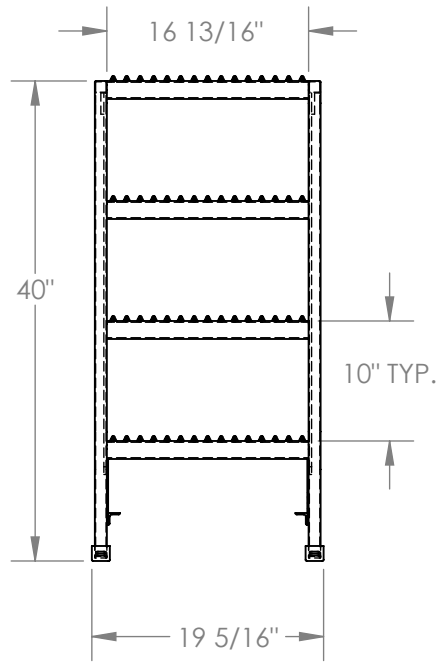

DIMENSION TOLERANCE $\pm 1/4$ "

STANDARD FEATURES

- MODEL NUMBER IS LAD-DD-18-4-G
- OVERALL WIDTH IS 19 5/16"
- USABLE WIDTH IS 16 13/16"
- OVERALL LENGTH IS 65 9/16"
- USABLE LENGTH IS 64 1/4"
- OVERALL HEIGHT IS 40"
- STEP DEPTH IS 7"
- TOP PLATFORM DEPTH IS 14"
- ANGLE OF INCLINE IS 50°
- STEP STYLE IS GRIP STRUT
- COLOR IS VESTIL BLUE
- MAX CAPACITY IS 350 LBS

NOTE

NONE

SPECIAL FEATURES

NONE

APPROVAL

I, THE UNDERSIGNED, AGREE THAT THE PRODUCT AS REPRESENTED SATISFIES DESIGN AND DIMENSION REQUIREMENTS. I ALSO ACKNOWLEDGE MY DUTY TO CONFIRM PRODUCT AND INSTALLATION COMPLIANCE WITH ALL APPLICABLE FEDERAL, STATE AND LOCAL REGULATIONS AND STANDARDS.
ALL SPECIAL UNITS ARE NON-RETURNABLE
[] As drawn [] As marked

Signed: _____ Date: _____

LEAD TIME WILL START UPON RECEIPT OF SIGNED APPROVAL DRAWING

FOR INTERNAL USE ONLY PROJECT SIGN OFF	
SALES	
ENG.	
FAB.	
POWER	

DISTRIBUTOR'S NAME:		P.O.#
VESTIL MANUFACTURING		X
W.O.#		X
DRAWN BY:	B.NOTHNAGEL	DATE: 06/09/2014
SALES:		X
REFERENCE:	X	SCALE: 1:16
FILE NAME:		44-007-509
QUOTED LEAD TIME:	X	QUOTE #
		X