

MAINTENANCE LADDER, GRIP STRUT - LAD-MM-10-G

APPROX WEIGHT: 211.72 lbs.
DOES NOT INCLUDE WEIGHT OF POWER OR PACKAGING!!!

*** ANY ADDITIONS, DELETIONS, OR OMISSIONS MUST BE CORRECTED ON THIS DRAWING AS THIS DRAWING WILL BE CONSIDERED ALL INCLUSIVE ***

ALL GRAPHICS PROVIDED ARE FOR REFERENCE ONLY. IF CERTAIN DIMENSIONS ARE CRITICAL PLEASE VERIFY THOSE DIMENSIONS WITH YOUR SALESPERSON

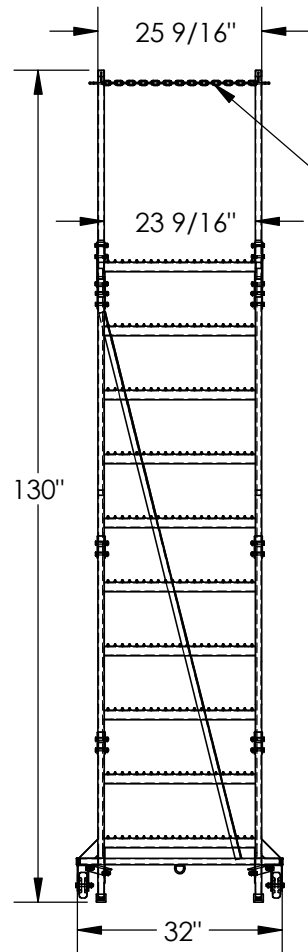

SAFETY CHAIN

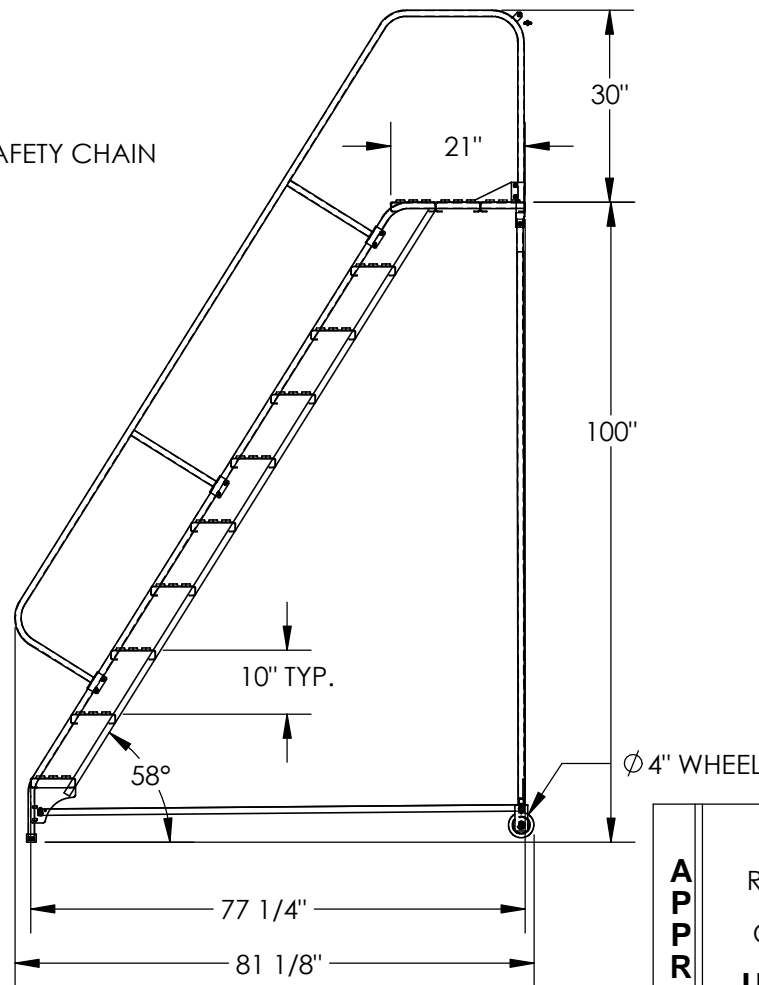

Ø 4" WHEEL

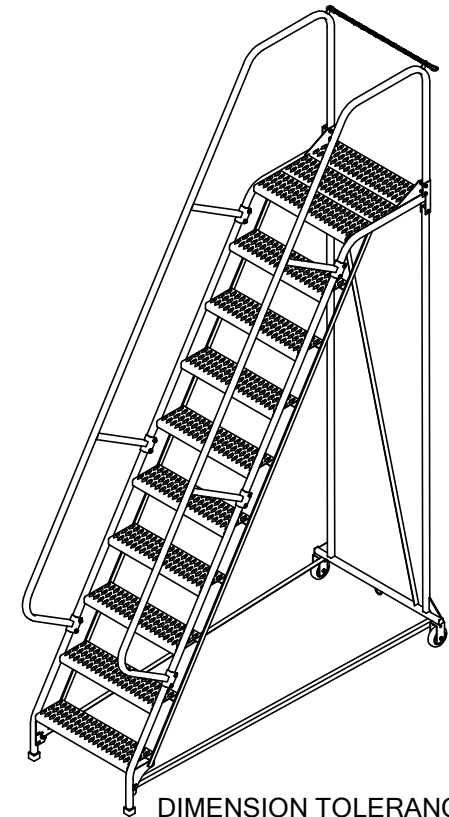

DIMENSION TOLERANCE ± 1/4"

STANDARD FEATURES

MODEL NUMBER IS LAD-MM-10-G
OVERALL WIDTH IS 32"
USABLE WIDTH IS 23 9/16"
OVERALL LENGTH IS 81 1/8"
USABLE LENGTH IS 77 1/4"
OVERALL HEIGHT IS 130"
PLATFORM HEIGHT IS 100"
STEP TYPE: GRIP STRUT STEPS
CLIMB ANGLE: 58°
STEP DIM. 24" X 7"
MAX CAPACITY IS 350 LBS
TOUGH BAKED IN POWDER COAT BLUE FINISH

SPECIAL FEATURES

NONE

NOTE

-SOME ASSEMBLY REQUIRED
-TOOL TRAY SOLD SEPARATELY

APPROVAL

I, THE UNDERSIGNED, AGREE THAT THE PRODUCT AS REPRESENTED SATISFIES DESIGN AND DIMENSION REQUIREMENTS. I ALSO ACKNOWLEDGE MY DUTY TO CONFIRM PRODUCT AND INSTALLATION COMPLIANCE WITH ALL APPLICABLE FEDERAL, STATE AND LOCAL REGULATIONS AND STANDARDS.
UNITS REQUIRING APPROVAL DRAWINGS OR MODIFIED ARE NON-RETURNABLE

[] As drawn [] As marked

Signed: _____ Date: _____

Printed Name: _____

LEAD TIME WILL START UPON RECEIPT OF SIGNED APPROVAL DRAWING

DISTRIBUTOR'S NAME:		P.O.#
VESTIL MANUFACTURING		X
DRAWN BY: B.NOTHNAGEL		W.O.#
DATE: 8/28/2015		X
REFERENCE: X	SCALE: 1:30	SALES: X
QUOTED LEAD TIME: X	QUOTE #	FILE NAME:
	X	44-007-305