

MAINTENANCE LADDER, PERFORATED - LAD-MM-11-P-YL APPROX WEIGHT: 228.53 lbs. DOES NOT INCLUDE WEIGHT OF POWER OR PACKAGING!!!

*** ANY ADDITIONS, DELETIONS, OR OMISSIONS MUST BE CORRECTED ON THIS DRAWING AS THIS DRAWING WILL BE CONSIDERED ALL INCLUSIVE ***

ALL GRAPHICS PROVIDED ARE FOR REFERENCE ONLY. IF CERTAIN DIMENSIONS ARE CRITICAL PLEASE VERIFY THOSE DIMENSIONS WITH YOUR SALESPERSON

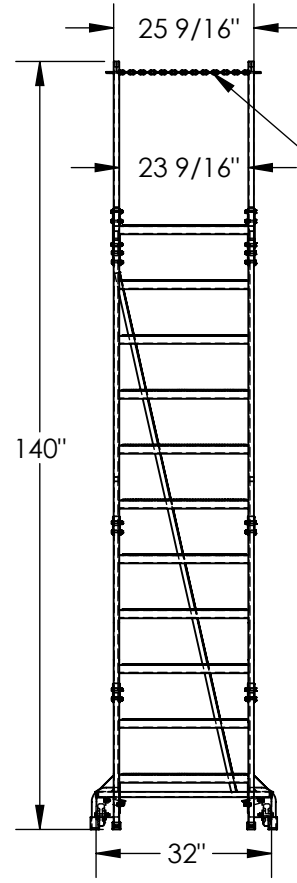

SAFETY CHAIN

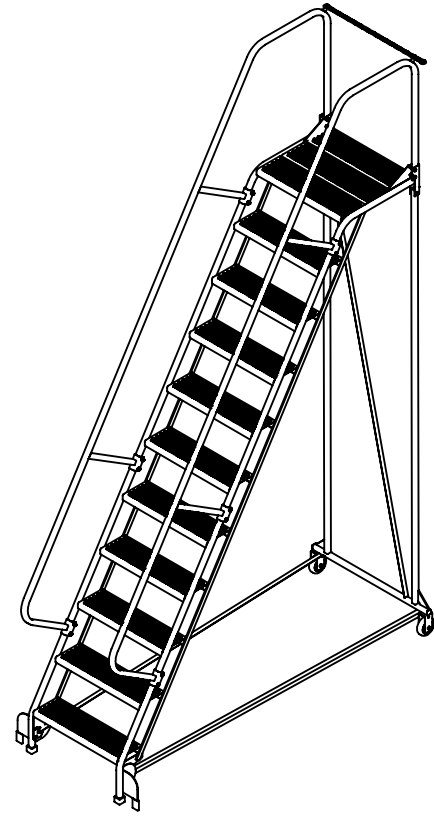
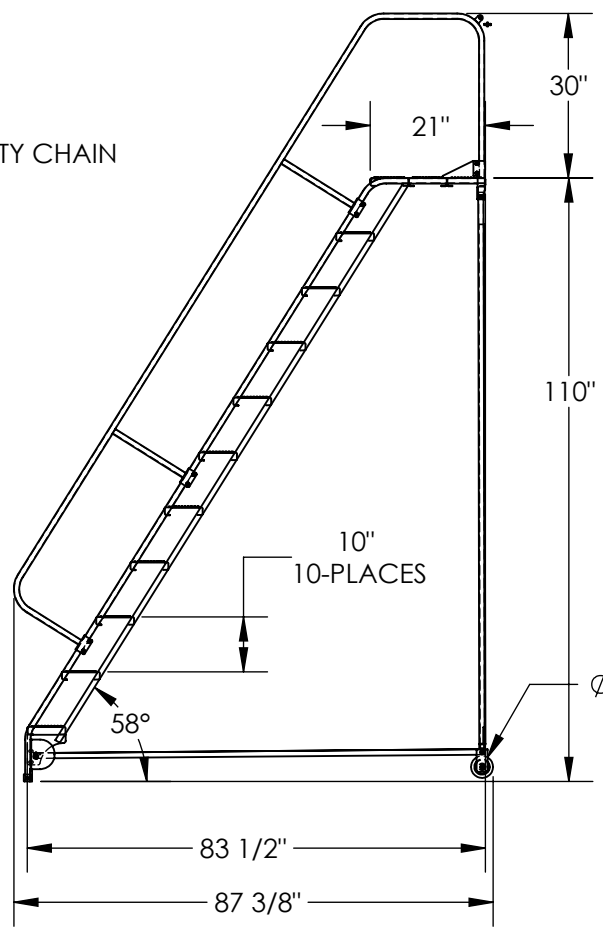

DIMENSION TOLERANCE ± 1/4"

STANDARD FEATURES

- MODEL NUMBER IS LAD-MM-11-P-YL
- OVERALL WIDTH IS 32"
- USABLE WIDTH IS 23 9/16"
- OVERALL LENGTH IS 87 3/8"
- USABLE LENGTH IS 83 1/2"
- OVERALL HEIGHT IS 140"
- PLATFORM HEIGHT IS 110"
- TOUGH BAKED IN POWDER COATED YELLOW FINISH
- STEP TYPE: PERFORATED STEPS
- CLIMB ANGLE: 58°
- STEP DIM. 24" X 7"
- MAX CAPACITY IS 350 LBS

SPECIAL FEATURES

- NONE
- NOTE**
- SOME ASSEMBLY REQUIRED
- TOOL TRAY SOLD SEPARATELY

I, THE UNDERSIGNED, AGREE THAT THE PRODUCT AS REPRESENTED SATISFIES DESIGN AND DIMENSION REQUIREMENTS. I ALSO ACKNOWLEDGE MY DUTY TO CONFIRM PRODUCT AND INSTALLATION COMPLIANCE WITH ALL APPLICABLE FEDERAL, STATE AND LOCAL REGULATIONS AND STANDARDS.

ANY MODIFIED UNITS ARE NON-RETURNABLE

[] As drawn [] As marked

Signed: _____ Date: _____

Printed Name: _____

LEAD TIME WILL START UPON RECEIPT OF SIGNED APPROVAL DRAWING

DISTRIBUTOR'S NAME:		P.O.#
VESTIL MANUFACTURING		X
DRAWN BY: JWW		W.O.#
DATE: 5/18/2020		X
REFERENCE: X	SCALE: 1:35	SALES: X
QUOTED LEAD TIME: X	QUOTE # X	FILE NAME:
		44-007-306-001

FOR INTERNAL USE ONLY PROJECT SIGN OFF	
SALES	
ENG.	
FAB.	
POWER	