

MAINTENANCE LADDER, GRIP STRUT - LAD-MM-4-G-YL

APPROX WEIGHT: 107.91 lbs.
 DOES NOT INCLUDE WEIGHT OF POWER OR PACKAGING!!!

*** ANY ADDITIONS, DELETIONS, OR OMISSIONS MUST BE CORRECTED ON THIS DRAWING AS THIS DRAWING WILL BE CONSIDERED ALL INCLUSIVE ***

ALL GRAPHICS PROVIDED ARE FOR REFERENCE ONLY. IF CERTAIN DIMENSIONS ARE CRITICAL PLEASE VERIFY THOSE DIMENSIONS WITH YOUR SALESPERSON

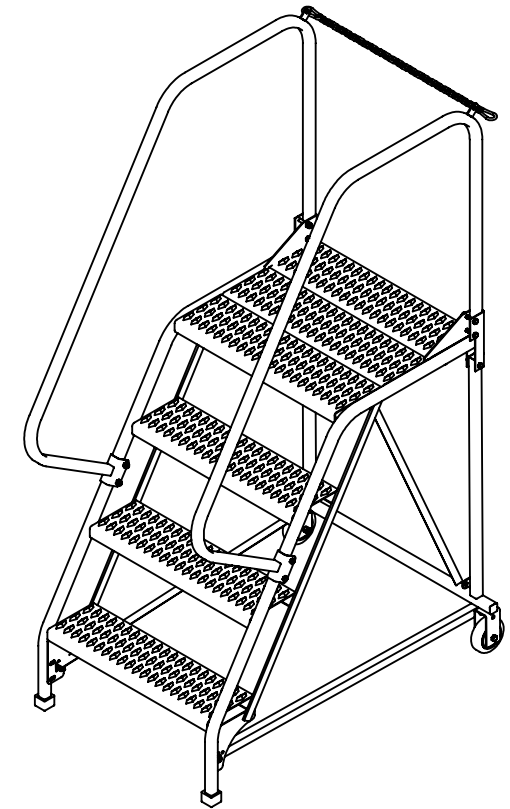
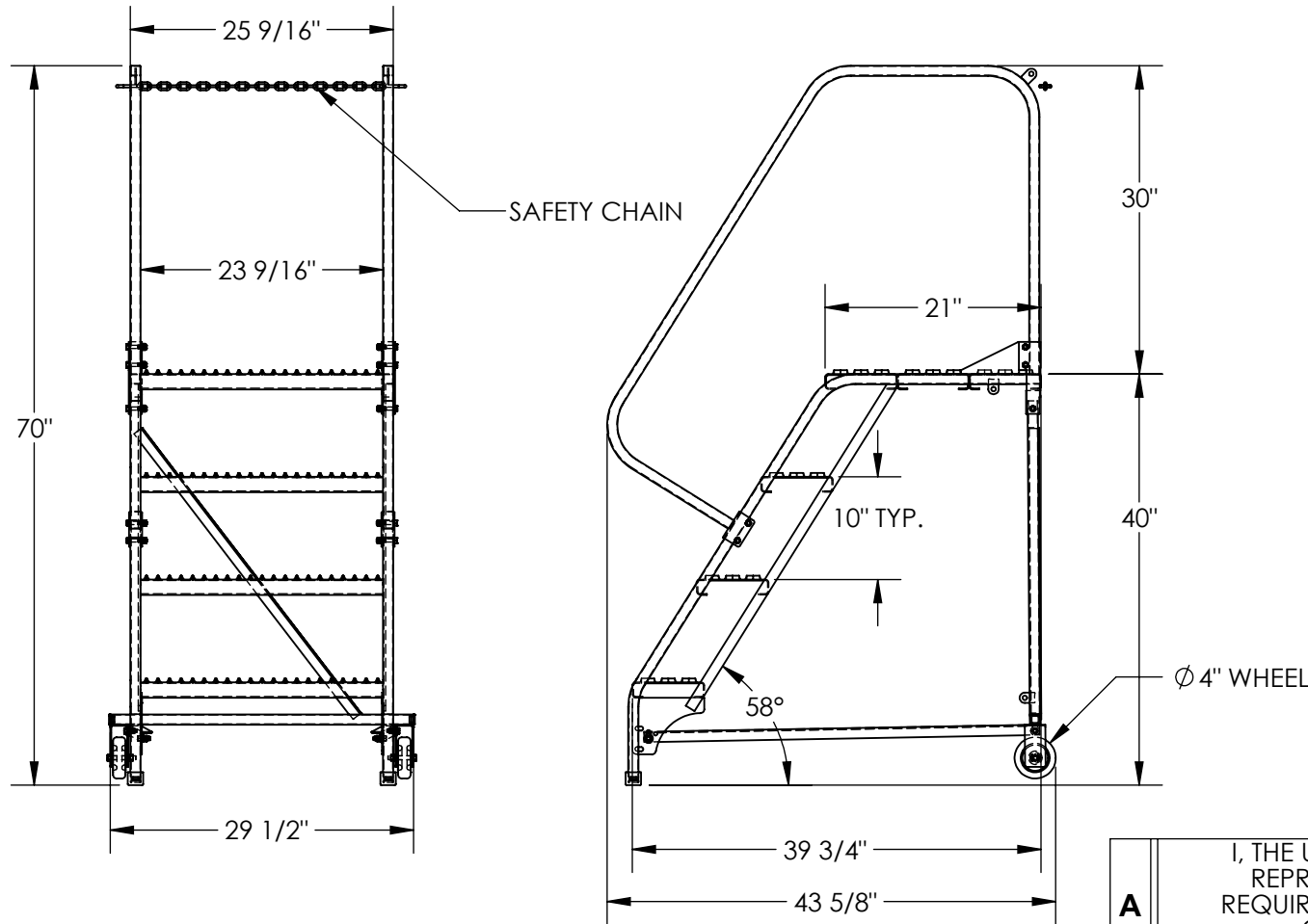

DIMENSION TOLERANCE ± 1/4"

STANDARD FEATURES

MODEL NUMBER IS LAD-MM-4-G-YL
 OVERALL WIDTH IS 29 1/2"
 USABLE WIDTH IS 23 9/16"
 OVERALL LENGTH IS 43 5/8"
 USABLE LENGTH IS 39 3/4"
 OVERALL HEIGHT IS 70"
 PLATFORM HEIGHT IS 40"
 TOUGH BAKED IN POWDER COATED YELLOW FINISH
 STEP TYPE: GRIP STRUT STEPS
 CLIMB ANGLE: 58°
 STEP DIM. 24" X 7"
 MAX CAPACITY IS 350 LBS

SPECIAL FEATURES

NONE
NOTE
 -SOME ASSEMBLY REQUIRED
 - TOOL TRAY SOLD SEPARATELY

APPROVAL	I, THE UNDERSIGNED, AGREE THAT THE PRODUCT AS REPRESENTED SATISFIES DESIGN AND DIMENSION REQUIREMENTS. I ALSO ACKNOWLEDGE MY DUTY TO CONFIRM PRODUCT AND INSTALLATION COMPLIANCE WITH ALL APPLICABLE FEDERAL, STATE AND LOCAL REGULATIONS AND STANDARDS.	
	ANY MODIFIED UNITS ARE NON-RETURNABLE	
	[] As drawn [] As marked	
	Signed: _____	Date: _____
Printed Name: _____		
LEAD TIME WILL START UPON RECEIPT OF SIGNED APPROVAL DRAWING		

FOR INTERNAL USE ONLY PROJECT SIGN OFF	
SALES	
ENG.	
FAB.	
POWER	

DISTRIBUTOR'S NAME:		P.O.#
VESTIL MANUFACTURING		X
DRAWN BY: JWW	DATE: 5/18/2020	W.O.#
REFERENCE: X	SCALE: 1:18	X
QUOTED LEAD TIME: X	QUOTE #	FILE NAME:
	X	44-007-174-001