

MAINTENANCE LADDER, GRIP STRUT - LAD-MM-8-G-YL

APPROX WEIGHT: 178.59 lbs.
DOES NOT INCLUDE WEIGHT OF POWER OR PACKAGING!!!

*** ANY ADDITIONS, DELETIONS, OR OMISSIONS MUST BE CORRECTED ON THIS DRAWING AS THIS DRAWING WILL BE CONSIDERED ALL INCLUSIVE ***

ALL GRAPHICS PROVIDED ARE FOR REFERENCE ONLY. IF CERTAIN DIMENSIONS ARE CRITICAL PLEASE VERIFY THOSE DIMENSIONS WITH YOUR SALESPERSON

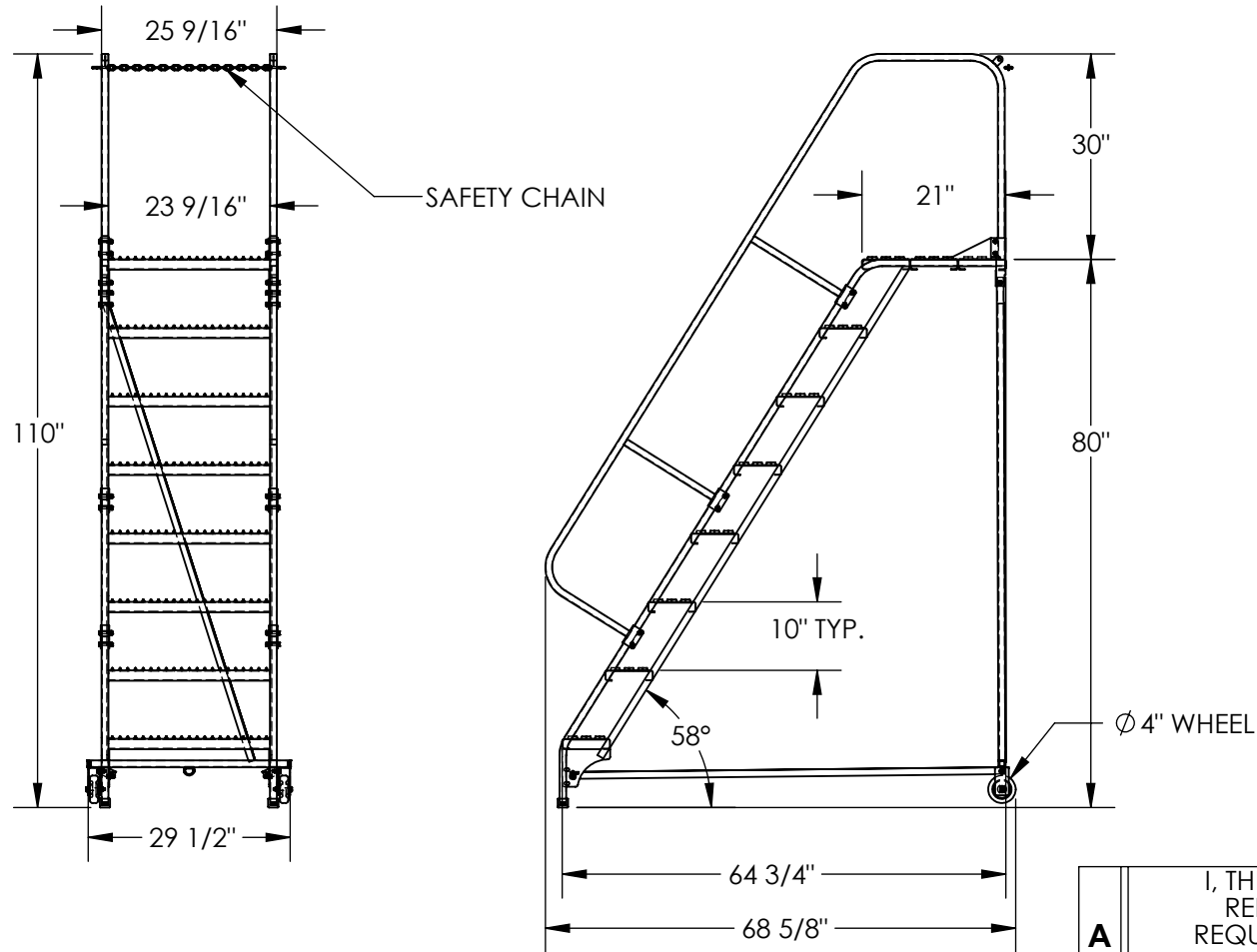

DIMENSION TOLERANCE ± 1/4"

STANDARD FEATURES

- MODEL NUMBER IS LAD-MM-8-G-YL
- OVERALL WIDTH IS 29 1/2"
- USABLE WIDTH IS 23 9/16"
- OVERALL LENGTH IS 68 5/8"
- USABLE LENGTH IS 64 3/4"
- OVERALL HEIGHT IS 110"
- PLATFORM HEIGHT IS 80"
- TOUGH BAKED IN POWDER COATED YELLOW FINISH
- STEP TYPE: GRIP STRUT STEPS
- CLIMB ANGLE: 58°
- STEP DIM. 24" X 7"
- MAX CAPACITY IS 350 LBS

SPECIAL FEATURES

- NONE
- NOTE**
- SOME ASSEMBLY REQUIRED
- TOLL TRAY SOLD SEPARATELY

A
P
R
O
V
A
L

I, THE UNDERSIGNED, AGREE THAT THE PRODUCT AS REPRESENTED SATISFIES DESIGN AND DIMENSION REQUIREMENTS. I ALSO ACKNOWLEDGE MY DUTY TO CONFIRM PRODUCT AND INSTALLATION COMPLIANCE WITH ALL APPLICABLE FEDERAL, STATE AND LOCAL REGULATIONS AND STANDARDS.

ANY MODIFIED UNITS ARE NON-RETURNABLE

[] As drawn [] As marked

Signed: _____ Date: _____

Printed Name: _____

LEAD TIME WILL START UPON RECEIPT OF SIGNED APPROVAL DRAWING

FOR INTERNAL USE ONLY PROJECT SIGN OFF	
SALES	
ENG.	
FAB.	
POWER	

DISTRIBUTOR'S NAME:		P.O.#
VESTIL MANUFACTURING		X
DRAWN BY:	DATE:	W.O.#
JWW	5/18/2020	X
REFERENCE:	SCALE:	SALES:
X	1:28	X
QUOTED LEAD TIME:	QUOTE #	FILE NAME:
X	X	44-007-301-001