

STANDARD SLOPE LADDER,NO HANDRAIL, SINGLE STEP, GRIP STRUT-LAD-PW-18-1-P-NHR

APPROX WEIGHT: 22.91 lbs.
 DOES NOT INCLUDE WEIGHT OF POWER OR PACKAGING!!!

*** ANY ADDITIONS, DELETIONS, OR OMISSIONS MUST BE CORRECTED ON THIS DRAWING AS THIS DRAWING WILL BE CONSIDERED ALL INCLUSIVE ***
 ALL GRAPHICS PROVIDED ARE FOR REFERENCE ONLY. IF CERTAIN DIMENSIONS ARE CRITICAL PLEASE VERIFY THOSE DIMENSIONS WITH YOUR SALESPERSON

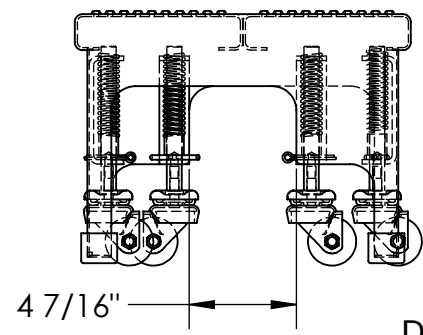
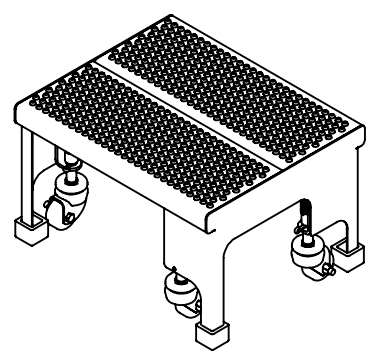
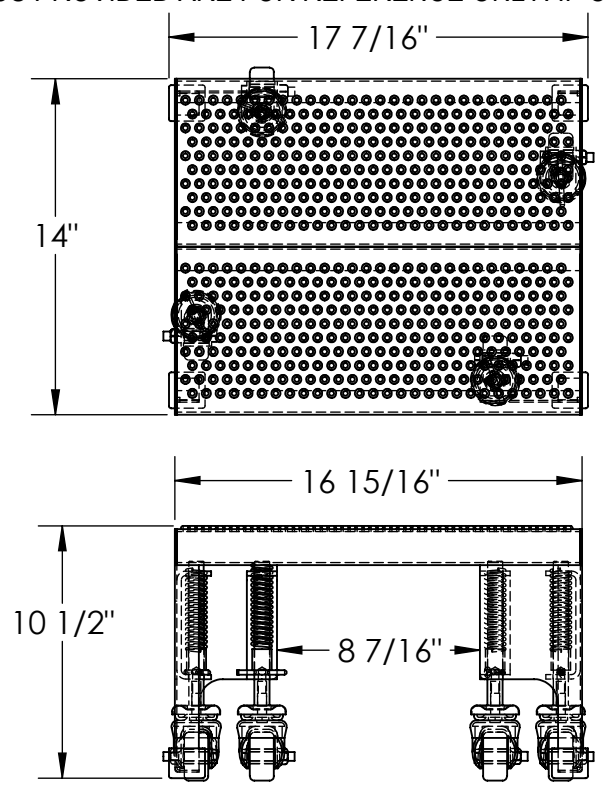

DIMENSION TOLERANCE ± 1/4"

STANDARD FEATURES

- MODEL NUMBER: LAD-PW-18-1-P-NHR
- OVERALL WIDTH: 17 7/16"
- USABLE WIDTH: 16 15/16"
- OVERALL LENGTH: 14"
- USABLE LENGTH: 14"
- OVERALL HEIGHT: 10 1/2"
- TOUGH BAKED IN POWDER COATED BLUE FINISH
- STEP TYPE: PERFORATED GRIP STRUT
- MAX CAPACITY: 350 LBS
- DIRECTIONAL SPRING-LOADED SWIVEL CASTERS

SPECIAL FEATURES

NONE

APPROVAL

I, THE UNDERSIGNED, AGREE THAT THE PRODUCT AS REPRESENTED SATISFIES DESIGN AND DIMENSION REQUIREMENTS. I ALSO ACKNOWLEDGE MY DUTY TO CONFIRM PRODUCT AND INSTALLATION COMPLIANCE WITH ALL APPLICABLE FEDERAL, STATE AND LOCAL REGULATIONS AND STANDARDS.

UNITS REQUIRING APPROVAL DRAWINGS OR MODIFIED ARE NON-RETURNABLE

As drawn As marked

Signed: _____ Date: _____

Printed Name: _____

LEAD TIME WILL START UPON RECEIPT OF SIGNED APPROVAL DRAWING

DISTRIBUTOR'S NAME:		P.O.#
VESTIL MANUFACTURING		X
DRAWN BY: X		W.O.#
DATE: XX/XX/XX		X
REFERENCE: X	SCALE: 1:8	SALES: X
QUOTED LEAD TIME: X	QUOTE #	FILE NAME:
	X	44-007-788