

STANDARD SLOPE LADDER, ELECTROSTATIC DISCHARGE, 8-STEP-LAD-PW-26-8-G-ESD APPROX WEIGHT: 182.95 lbs. DOES NOT INCLUDE WEIGHT OF POWER OR PACKAGING!!!

*** ANY ADDITIONS, DELETIONS, OR OMISSIONS MUST BE CORRECTED ON THIS DRAWING AS THIS DRAWING WILL BE CONSIDERED ALL INCLUSIVE ***
 ALL GRAPHICS PROVIDED ARE FOR REFERENCE ONLY. IF CERTAIN DIMENSIONS ARE CRITICAL PLEASE VERIFY THOSE DIMENSIONS WITH YOUR SALESPERSON

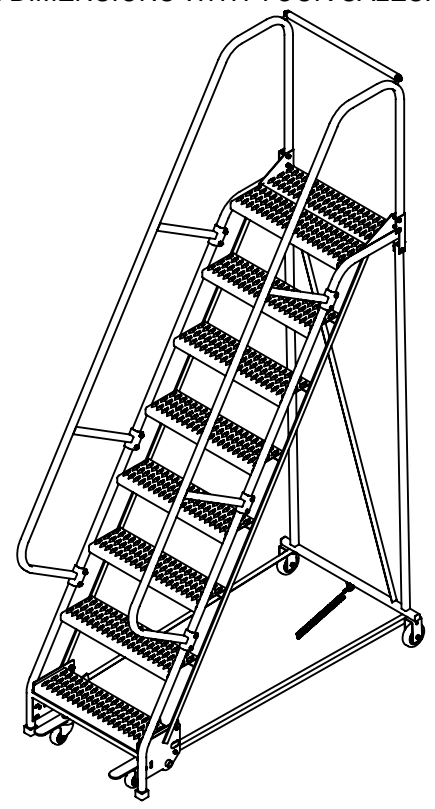
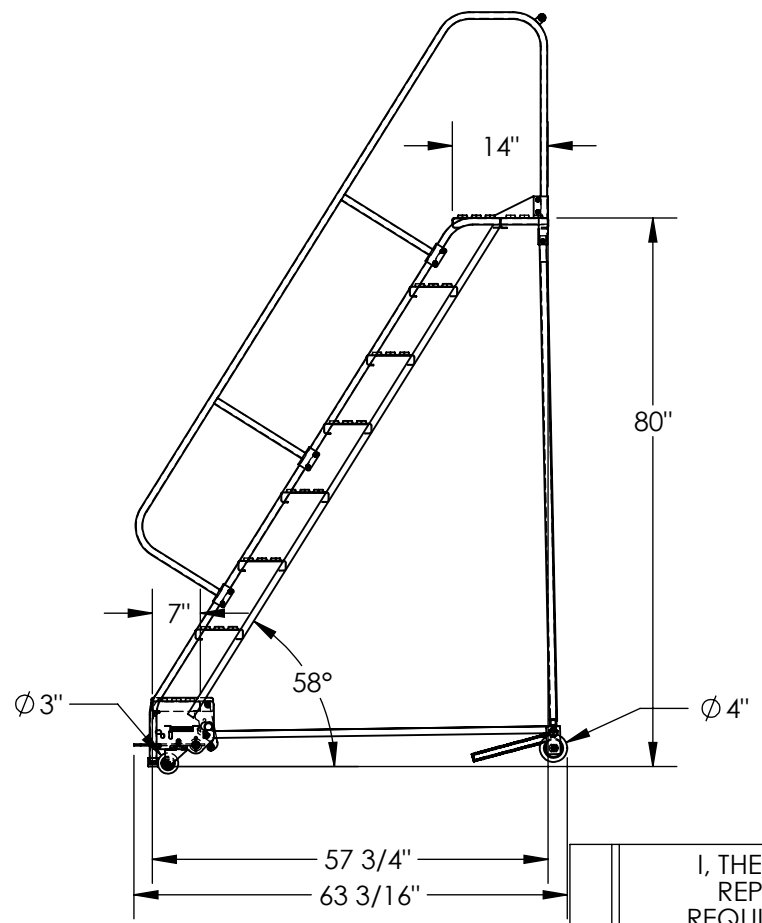
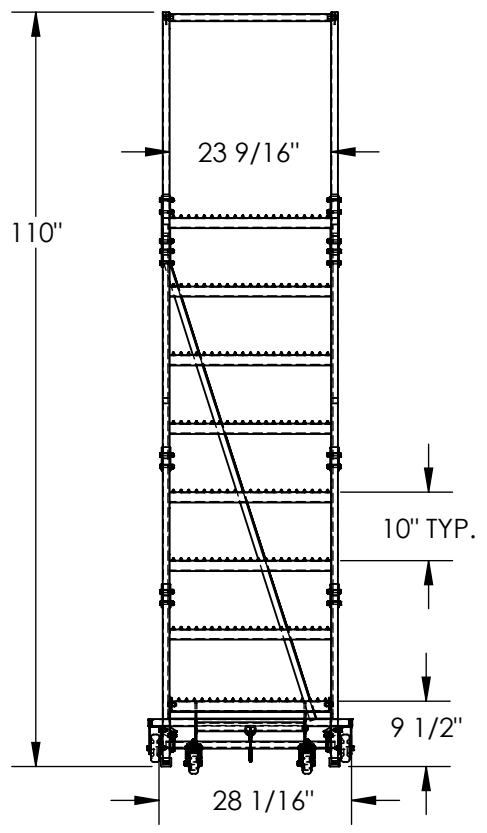

DIMENSION TOLERANCE ± 1/4"

STANDARD FEATURES

- MODEL NUMBER IS LAD-PW-26-8-G-ESD
- OVERALL WIDTH IS 28 1/16"
- USABLE WIDTH IS 23 9/16"
- OVERALL LENGTH IS 63 3/16"
- USABLE LENGTH IS 57 3/4"
- OVERALL HEIGHT IS 110"
- PLATFORM HEIGHT IS 80"
- STEP TYPE IS GRIP STRUT
- CLIMB ANGLE IS 58°
- STEP DEPTH IS 7"
- PLATFORM DEPTH IS 14"
- TOUGH BAKED IN POWDER COATED BLACK ESD FINISH
- MAX CAPACITY IS 350 LBS
- FRONT WHEEL IS SWIVEL, SIZE IS Ø 3"
- REAR WHEEL IS RIGID, SIZE IS Ø 4"

NOTE

- SOME ASSEMBLY REQUIRED
- TOOL TRAY SOLD SEPARATELY
- OPTIONAL ESD GROUNDING STRAPS SOLD SEPERATELY

SPECIAL FEATURES

NONE

APPROVAL

I, THE UNDERSIGNED, AGREE THAT THE PRODUCT AS REPRESENTED SATISFIES DESIGN AND DIMENSION REQUIREMENTS. I ALSO ACKNOWLEDGE MY DUTY TO CONFIRM PRODUCT AND INSTALLATION COMPLIANCE WITH ALL APPLICABLE FEDERAL, STATE AND LOCAL REGULATIONS AND STANDARDS.

UNITS REQUIRING APPROVAL DRAWINGS OR MODIFIED ARE NON-RETURNABLE

[] As drawn [] As marked

Signed: _____ Date: _____

LEAD TIME WILL START UPON RECEIPT OF SIGNED APPROVAL DRAWING

DISTRIBUTOR'S NAME:		P.O.#
VESTIL MANUFACTURING		X
DRAWN BY: B.NOTHNAGEL		DATE: 9/21/2015
REFERENCE: X		SCALE: 1:28
QUOTED LEAD TIME: X	QUOTE #	FILE NAME:
X	X	44-007-501