

# 4-STEP, 50° ROLL-A-FOLD LADDER, GRIP STRUT- LAD-RAF-4-G-EZ

APPROX WEIGHT: 168.60 lbs.  
DOES NOT INCLUDE WEIGHT OF POWER OR PACKAGING!!!

\*\*\* ANY ADDITIONS, DELETIONS, OR OMISSIONS MUST BE CORRECTED ON THIS DRAWING AS THIS DRAWING WILL BE CONSIDERED ALL INCLUSIVE \*\*\*

ALL GRAPHICS PROVIDED ARE FOR REFERENCE ONLY. IF CERTAIN DIMENSIONS ARE CRITICAL PLEASE VERIFY THOSE DIMENSIONS WITH YOUR SALESPERSON

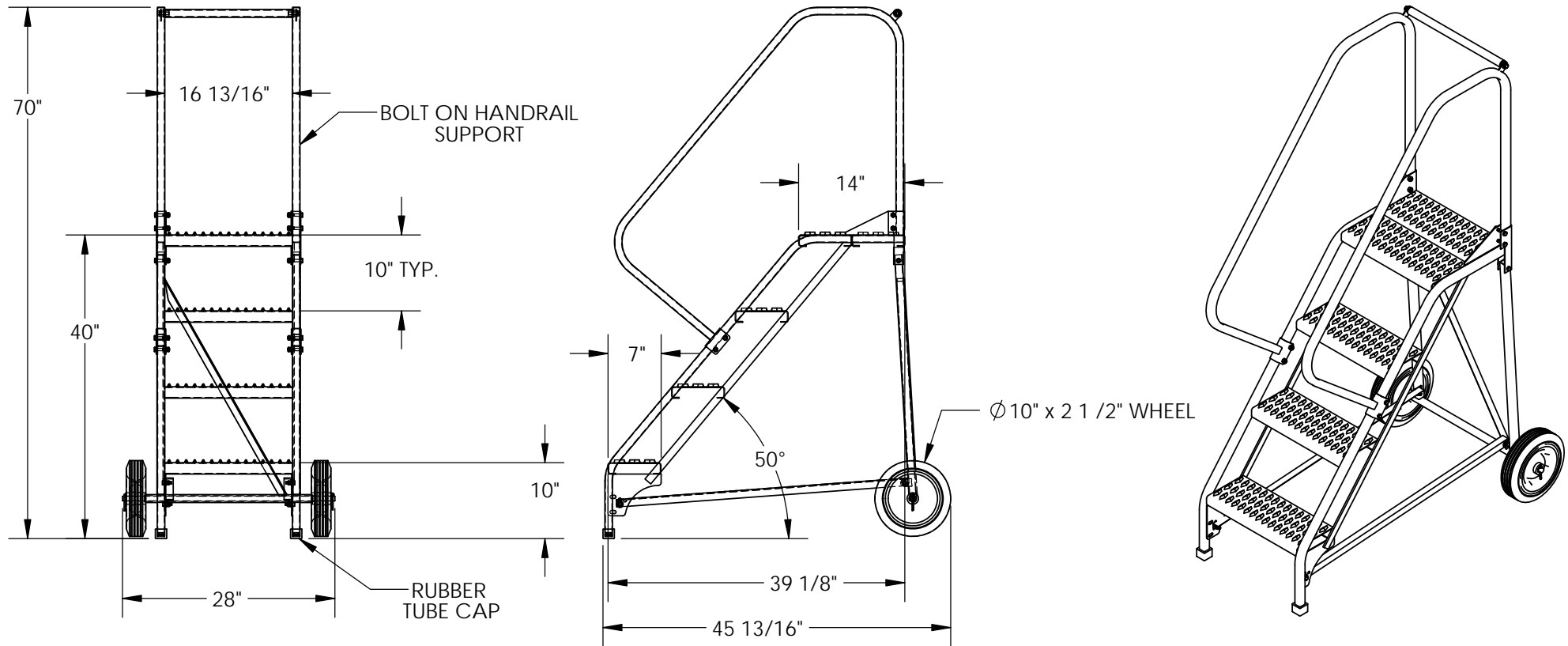

DIMENSION TOLERANCE ± 1/4"

## STANDARD FEATURES

- MODEL NUMBER IS LAD-RAF-4-G-EZ
- OVERALL WIDTH IS 28"
- USABLE WIDTH IS 16 13/16"
- OVERALL LENGTH IS 45 13/16"
- USABLE LENGTH IS 39 1/8"
- OVERALL HEIGHT IS 70"
- PLATFORM HEIGHT IS 40"
- STEP DEPTH IS 7"
- PLATFORM DEPTH IS 14"
- CLIMB ANGLE IS 50°
- COLOR IS VESTIL BLUE
- STEP STYLE IS GRIP STRUT
- MAX CAPACITY IS 350 LBS
- FOLDED DIMENSION: 79" X 30" X 30" (NOT SHOWN)

## NOTE

SOME ASSEMBLY REQUIRED  
TOOL TRAY SOLD SEPARATELY

## SPECIAL FEATURES

NONE

<b>A P P R O V A L</b>	I, THE UNDERSIGNED, AGREE THAT THE PRODUCT AS REPRESENTED SATISFIES DESIGN AND DIMENSION REQUIREMENTS. I ALSO ACKNOWLEDGE MY DUTY TO CONFIRM PRODUCT AND INSTALLATION COMPLIANCE WITH ALL APPLICABLE FEDERAL, STATE AND LOCAL REGULATIONS AND STANDARDS.	
	<b>ANY MODIFIED UNITS ARE NON-RETURNABLE</b>	
	[ ] As drawn      [ ] As marked	
	Signed: _____	Date: _____
Printed Name: _____		
LEAD TIME WILL START UPON RECEIPT OF SIGNED APPROVAL DRAWING		

FOR INTERNAL USE ONLY PROJECT SIGN OFF	
SALES	
ENG.	
FAB.	
POWER	

DISTRIBUTOR'S NAME:		P.O.#
VESTIL MANUFACTURING		X
DRAWN BY:	DATE:	W.O.#
B.NOETHNAGEL	8/17/2015	X
REFERENCE:	SCALE:	SALES:
X	1:20	X
QUOTED LEAD TIME:	QUOTE #	FILE NAME:
X	X	44-007-415