

5-STEP, 50° ROLL-A-FOLD LADDER, GRIP STRUT - LAD-RAF-5-G-EZ

APPROX WEIGHT: 183.13 lbs.
DOES NOT INCLUDE WEIGHT OF POWER OR PACKAGING!!!

*** ANY ADDITIONS, DELETIONS, OR OMISSIONS MUST BE CORRECTED ON THIS DRAWING AS THIS DRAWING WILL BE CONSIDERED ALL INCLUSIVE ***

ALL GRAPHICS PROVIDED ARE FOR REFERENCE ONLY. IF CERTAIN DIMENSIONS ARE CRITICAL PLEASE VERIFY THOSE DIMENSIONS WITH YOUR SALESPERSON

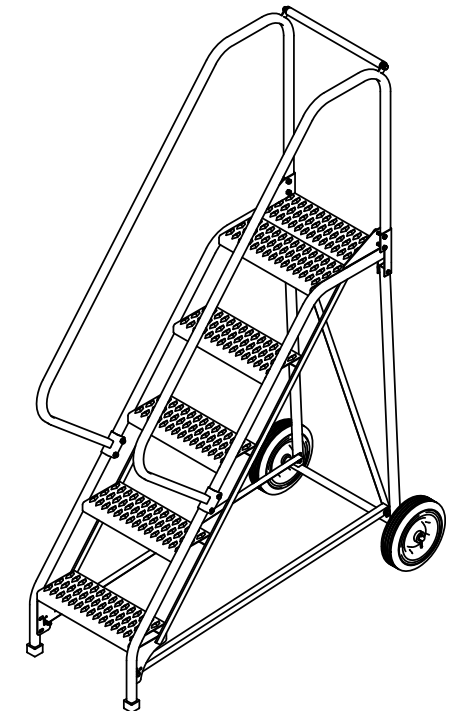
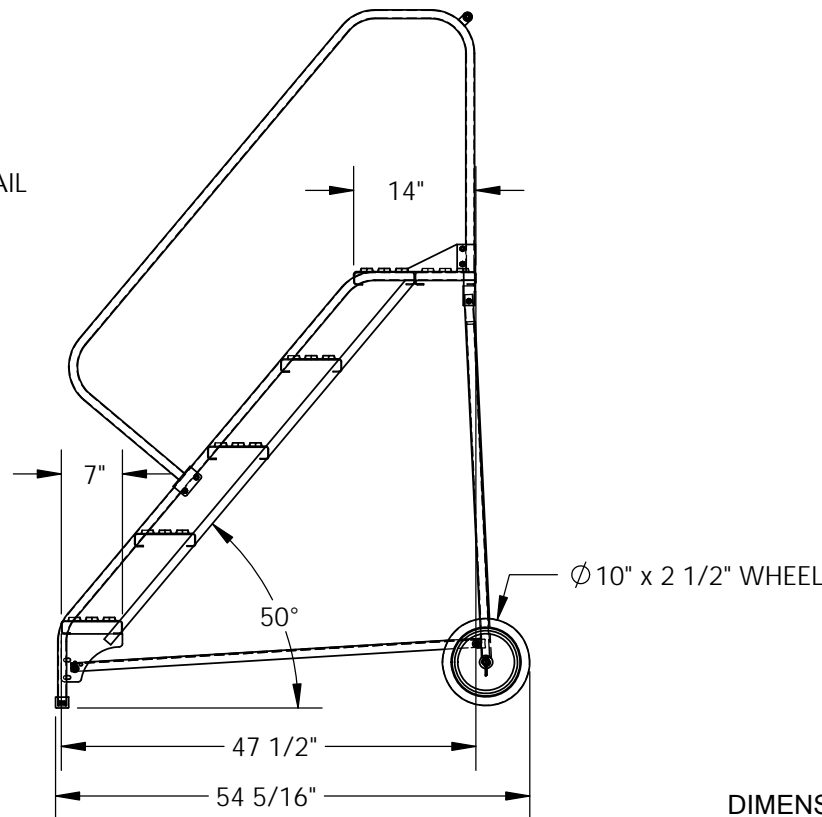
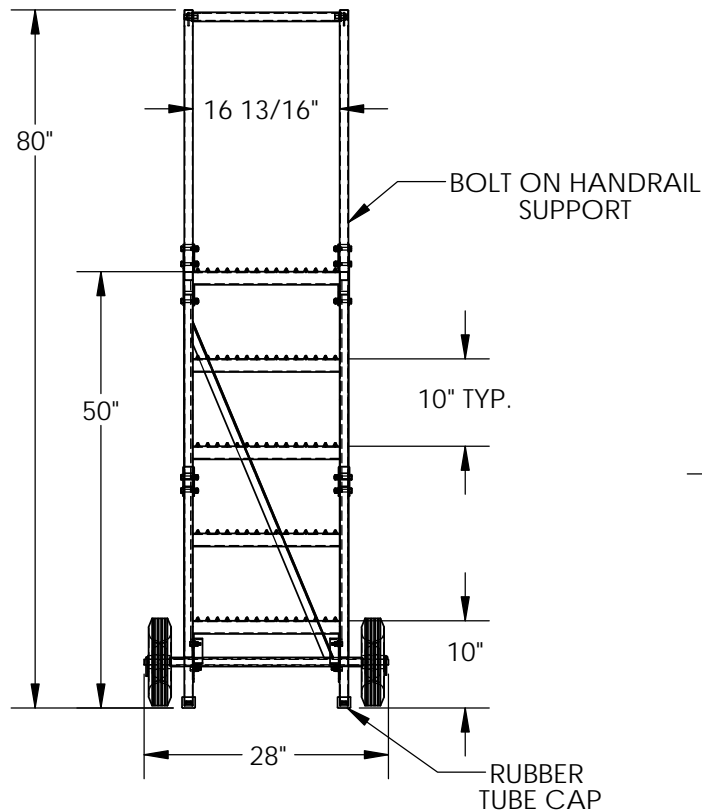

DIMENSION TOLERANCE ± 1/4"

STANDARD FEATURES

- MODEL NUMBER IS LAD-RAF-5-G-EZ
- OVERALL WIDTH IS 28"
- USABLE WIDTH IS 16 13/16"
- OVERALL LENGTH IS 54 5/16"
- USABLE LENGTH IS 47 1/2"
- OVERALL HEIGHT IS 80"
- PLATFORM HEIGHT IS 50"
- STEP DEPTH IS 7"
- PLATFORM DEPTH IS 14"
- CLIMB ANGLE IS 50°
- COLOR IS VESTIL BLUE
- STEP STYLE IS GRIP STRUT
- MAX CAPACITY IS 350 LBS
- FOLDED DIMENSION: 92" X 30" X 30" (NOT SHOWN)

NOTE

SOME ASSEMBLY REQUIRED
TOOL TRAY SOLD SEPARATELY

SPECIAL FEATURES

NONE

APPROVAL

I, THE UNDERSIGNED, AGREE THAT THE PRODUCT AS REPRESENTED SATISFIES DESIGN AND DIMENSION REQUIREMENTS. I ALSO ACKNOWLEDGE MY DUTY TO CONFIRM PRODUCT AND INSTALLATION COMPLIANCE WITH ALL APPLICABLE FEDERAL, STATE AND LOCAL REGULATIONS AND STANDARDS.

ANY MODIFIED UNITS ARE NON-RETURNABLE

[] As drawn [] As marked

Signed: _____ Date: _____

Printed Name: _____

LEAD TIME WILL START UPON RECEIPT OF SIGNED APPROVAL DRAWING

FOR INTERNAL USE ONLY PROJECT SIGN OFF	
SALES	
ENG.	
FAB.	
POWER	

DISTRIBUTOR'S NAME:		P.O.#
VESTIL MANUFACTURING		X
DRAWN BY: B.NOTHNAGEL		W.O.#
DATE: 8/17/2015		X
REFERENCE: X	SCALE: 1:22	SALES: X
QUOTED LEAD TIME: X	QUOTE #	FILE NAME:
	X	44-007-194