

NESTABLE MULTI-USE CART WITH BRAKE - LUG-B-GH

APPROX WEIGHT: 264 lbs.
DOES NOT INCLUDE WEIGHT OF POWER OR PACKAGING!!!

*** ANY ADDITIONS, DELETIONS, OR OMISSIONS MUST BE CORRECTED ON THIS DRAWING AS THIS DRAWING WILL BE CONSIDERED ALL INCLUSIVE ***

ALL GRAPHICS PROVIDED ARE FOR REFERENCE ONLY. IF CERTAIN DIMENSIONS ARE CRITICAL PLEASE VERIFY THOSE DIMENSIONS WITH YOUR SALESPERSON

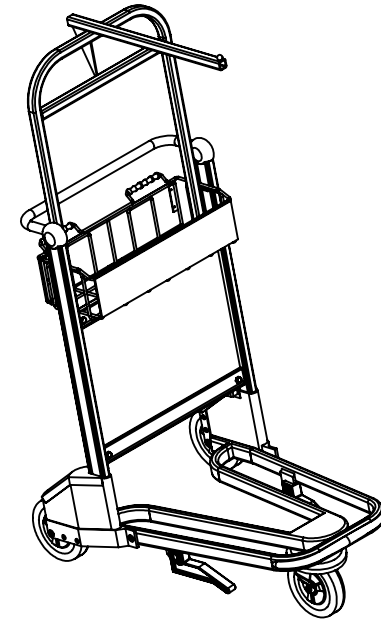
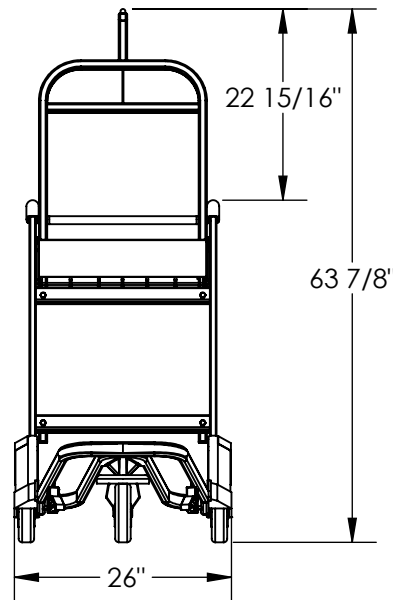
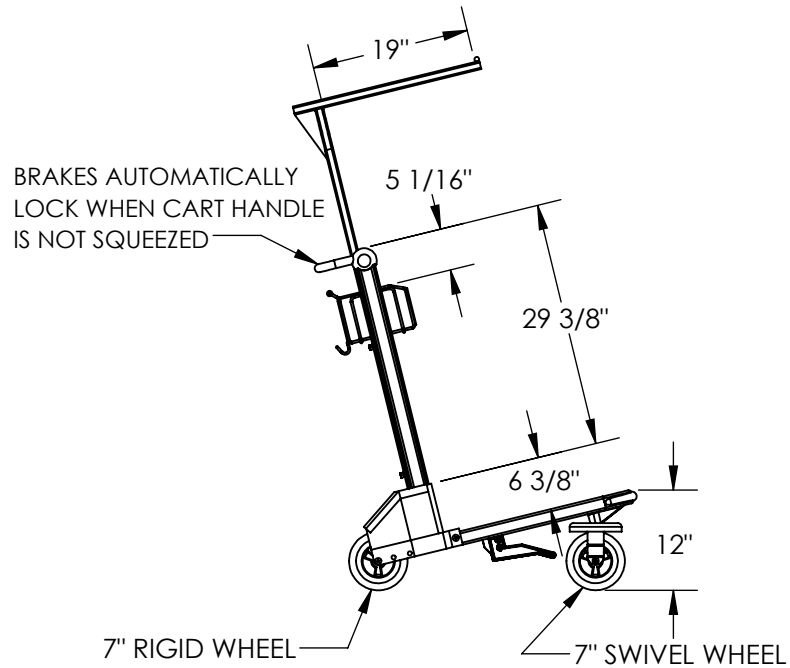
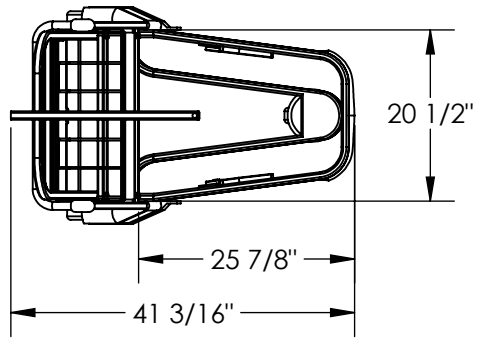

DIMENSION TOLERANCE ± 1/4"

STANDARD FEATURES

- MODEL NUMBER IS LUG-B-GH
- OVERALL WIDTH IS 26"
- USABLE WIDTH IS 20 1/2"
- OVERALL LENGTH IS 41 3/16"
- USABLE LENGTH IS 25 7/8"
- OVERALL HEIGHT IS 63 7/8"
- MAX CAPACITY IS 550lb
- GARMENT HOOK USABLE LENGTH IS 19"
- (1) 7" SWIVEL WHEEL
- (2) 7" RIGID WHEEL
- ALUMINUM CONSTRUCTION

SPECIAL FEATURES

NONE

APPROVAL

I, THE UNDERSIGNED, AGREE THAT THE PRODUCT AS REPRESENTED SATISFIES DESIGN AND DIMENSION REQUIREMENTS. I ALSO ACKNOWLEDGE MY DUTY TO CONFIRM PRODUCT AND INSTALLATION COMPLIANCE WITH ALL APPLICABLE FEDERAL, STATE AND LOCAL REGULATIONS AND STANDARDS.
UNITS REQUIRING APPROVAL DRAWINGS OR MODIFIED ARE NON-RETURNABLE
[] As drawn [] As marked

Signed: _____ Date: _____

Printed Name: _____

LEAD TIME WILL START UPON RECEIPT OF SIGNED APPROVAL DRAWING

DISTRIBUTOR'S NAME:		P.O.#
VESTIL MANUFACTURING		X
DRAWN BY: MAS	DATE: 09/17/2021	W.O.#
REFERENCE: X	SCALE: 1:23	X
QUOTED LEAD TIME: X	QUOTE #	SALES: X
	X	FILE NAME:
		30-007-312