

MEZZANINE SAFETY GATE, MEZZ-200-DW-SS

APPROX WEIGHT: 209.03 lbs.
DOES NOT INCLUDE WEIGHT OF POWER OR PACKAGING!!!

*** ANY ADDITIONS, DELETIONS, OR OMISSIONS MUST BE CORRECTED ON THIS DRAWING AS THIS DRAWING WILL BE CONSIDERED ALL INCLUSIVE ***
ALL GRAPHICS PROVIDED ARE FOR REFERENCE ONLY. IF CERTAIN DIMENSIONS ARE CRITICAL PLEASE VERIFY THOSE DIMENSIONS WITH YOUR SALESPERSON

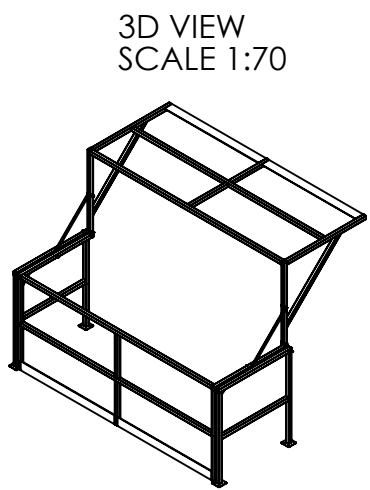
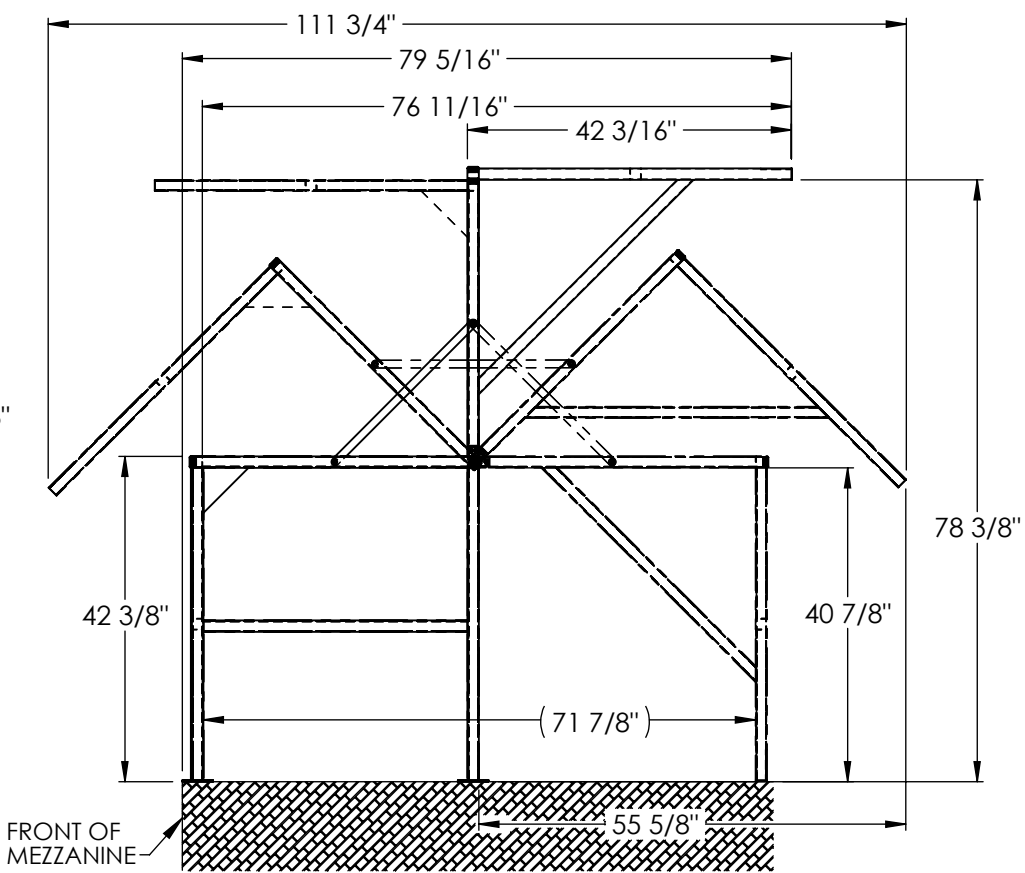
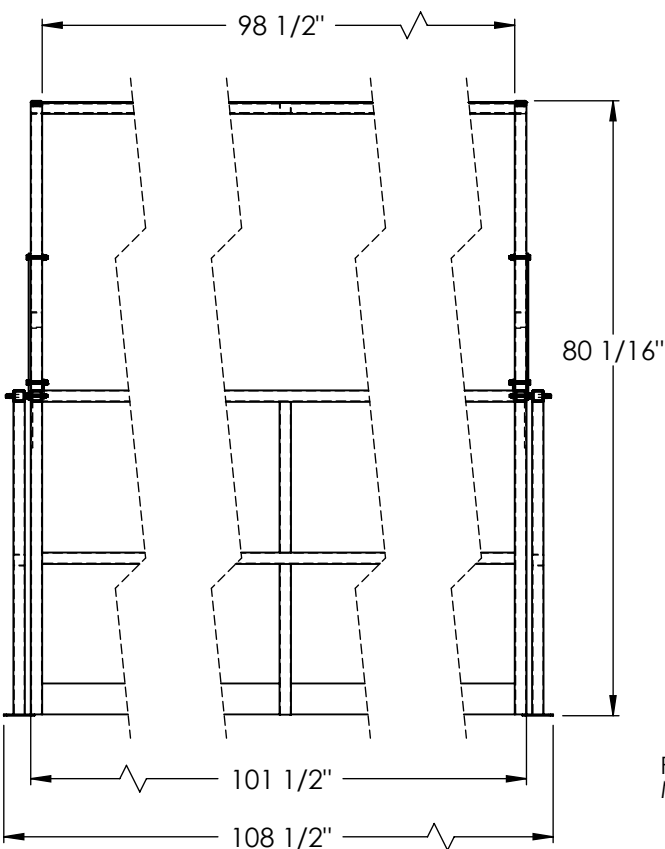

*NOTE: USABLE LOAD SIZE IS DEPENDENT UPON BOTH THE LOAD HEIGHT AND LOAD DEPTH, ALONG WITH THE PLACEMENT OF THE LOAD WITHIN THIS GATE; TALLER LOADS WILL HAVE TO BE SHORTER IN DEPTH, & DEEPER LOADS WILL HAVE TO BE SHORTER IN HEIGHT, IN ORDER FOR THE GATES TO CLEAR THE LOAD; WITH A TALLER & DEEPER LOAD, LOAD PLACEMENT WILL BE MORE CRITICAL, AS WELL AS LIMITED

STANDARD FEATURES

- MODEL NUMBER: MEZZ-200-DW-SS
- OVERALL WIDTH: 108 1/2"
- INSIDE WIDTH: 98 1/2"
- USABLE WIDTH: 96"
- OVERALL HEIGHT: 80 1/16"
- INSIDE HEIGHT: 78 3/8"
- OVERALL DEPTH: 79 5/16"
- INSIDE DEPTH: 76 11/16"
- HANDRAIL HEIGHT: 42 3/8"
- *USABLE ENVELOPE (SEE NOTE)
- STAINLESS STEEL CONSTRUCTION WITH UNPOLISHED (MILL) FINISH
- INCLUDES STAINLESS STEEL HARDWARE
- **ANCHORING HARDWARE NOT INCLUDED**

SPECIAL FEATURES

NONE

MOUNTING BRACKET DETAIL SCALE 1:4

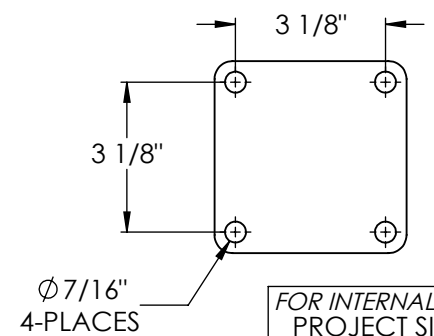

FOR INTERNAL USE ONLY PROJECT SIGN OFF	
SALES	
ENG.	
FAB.	
POWER	

A P P R O V A L

I, THE UNDERSIGNED, AGREE THAT THE PRODUCT AS REPRESENTED SATISFIES DESIGN AND DIMENSION REQUIREMENTS. I ALSO ACKNOWLEDGE MY DUTY TO CONFIRM PRODUCT AND INSTALLATION COMPLIANCE WITH ALL APPLICABLE FEDERAL, STATE AND LOCAL REGULATIONS AND STANDARDS.

ANY MODIFIED UNITS ARE NON-RETURNABLE

[] As drawn [] As marked

Signed: _____ Date: _____

Printed Name: _____

LEAD TIME WILL START UPON RECEIPT OF SIGNED APPROVAL DRAWING

DISTRIBUTOR'S NAME:		P.O.#
VESTIL MANUFACTURING		X
DRAWN BY: TJM		DATE: 01/30/17
REFERENCE: X		SCALE: 1:25
QUOTED LEAD TIME: X		QUOTE # X
		SALES: X
		FILE NAME: 23-007-656