

KNOCK DOWN MEZZANINE GATE: MEZZ-KD-88T-93D-A

*** ANY ADDITIONS, DELETIONS, OR OMISSIONS MUST BE CORRECTED ON THIS DRAWING AS THIS DRAWING WILL BE CONSIDERED ALL INCLUSIVE ***
 ALL GRAPHICS PROVIDED ARE FOR REFERENCE ONLY. IF CERTAIN DIMENSIONS ARE CRITICAL PLEASE VERIFY THOSE DIMENSIONS WITH YOUR SALESPERSON

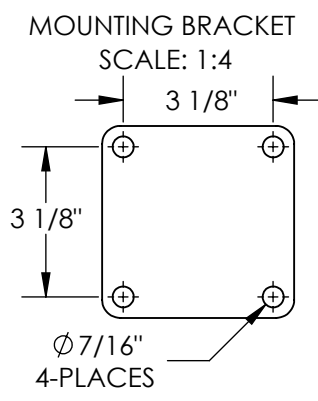
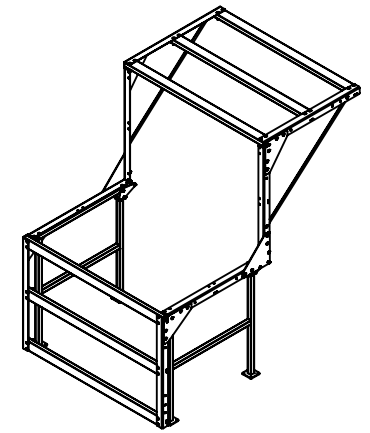
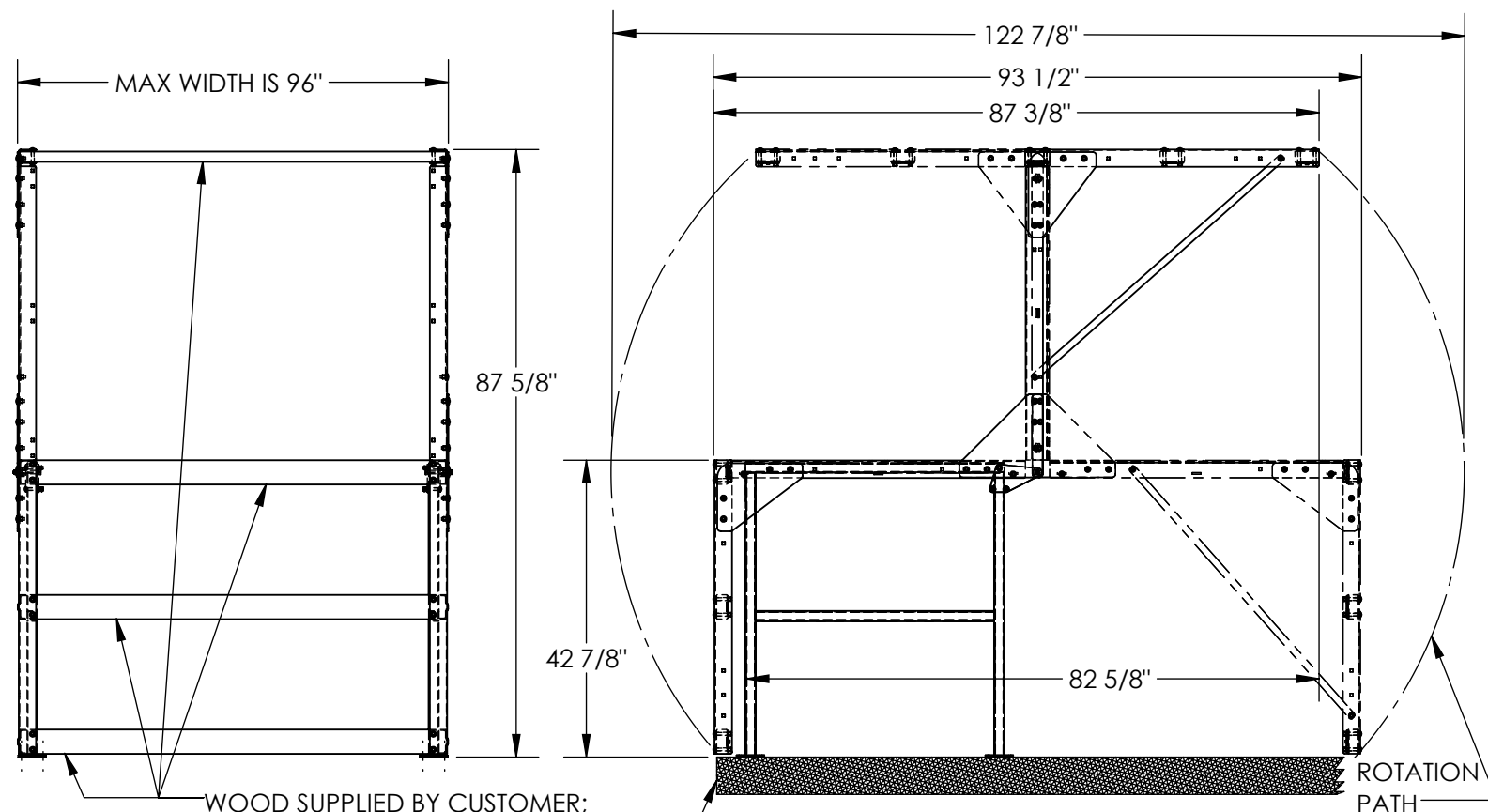

WOOD SUPPLIED BY CUSTOMER;
 MAX OVERALL WIDTH: 96"
 (SHOWN FOR REFERENCE ONLY)

FRONT OF MEZZANINE
 *NOTE: USABLE LOAD SIZE IS DEPENDENT UPON BOTH THE LOAD HEIGHT AND LOAD DEPTH, ALONG WITH THE PLACEMENT OF THE LOAD WITHIN THIS GATE; TALLER LOADS WILL HAVE TO BE SHORTER IN DEPTH, & DEEPER LOADS WILL HAVE TO BE SHORTER IN HEIGHT, IN ORDER FOR THE GATES TO CLEAR THE LOAD; WITH A TALLER & DEEPER LOAD, LOAD PLACEMENT WILL BE MORE CRITICAL, AS WELL AS LIMITED

DIMENSION TOLERANCE ± 1/4"

STANDARD FEATURES

MODEL NUMBER: MEZZ-KD-88T-93D-A
 WIDTH OF MODEL IS DETERMINED BY LENGTH OF WOODEN CROSS RAILS
 OVERALL DEPTH: 93 1/2"
 INSIDE DEPTH: 82 5/8"
 HANDRAIL HEIGHT: 42 7/8"
 OVERALL HEIGHT: 87 5/8"
 *USABLE ENVELOPE (SEE NOTE)
 ALUMINUM CONSTRUCTION
 ASSEMBLY REQUIRED.
 WOODEN CROSS RAILS ARE NOT INCLUDED
 APPROXIMATE WEIGHT IS 61 LBS.

SPECIAL FEATURES

NONE

APPROVAL

I, THE UNDERSIGNED, AGREE THAT THE PRODUCT AS REPRESENTED SATISFIES DESIGN AND DIMENSION REQUIREMENTS. I ALSO ACKNOWLEDGE MY DUTY TO CONFIRM PRODUCT AND INSTALLATION COMPLIANCE WITH ALL APPLICABLE FEDERAL, STATE AND LOCAL REGULATIONS AND STANDARDS.
ANY MODIFIED UNITS ARE NON-RETURNABLE
 As drawn As marked

Signed: _____ Date: _____
 Printed Name: _____
LEAD TIME WILL START UPON RECEIPT OF SIGNED APPROVAL DRAWING

FOR INTERNAL USE ONLY PROJECT SIGN OFF	
SALES	
ENG.	
FAB.	
POWER	

DISTRIBUTOR'S NAME:		P.O.#
VESTIL MANUFACTURING		X
DRAWN BY: TJM	DATE: 06/25/2020	W.O.#
REFERENCE: X	SCALE: 1:26	X
QUOTED LEAD TIME: X	QUOTE #	FILE NAME:
	X	23-007-757