

# MECHANICAL POST TABLE - MT-3042-HP

APPROX WEIGHT: 365.63 lbs.  
 DOES NOT INCLUDE WEIGHT OF POWER OR PACKAGING!!!

\*\*\*ANY ADDITIONS, DELETIONS, OR OMISSIONS MUST BE CORRECTED ON THIS DRAWING AS THIS DRAWING WILL BE CONSIDERED ALL INCLUSIVE\*\*\*

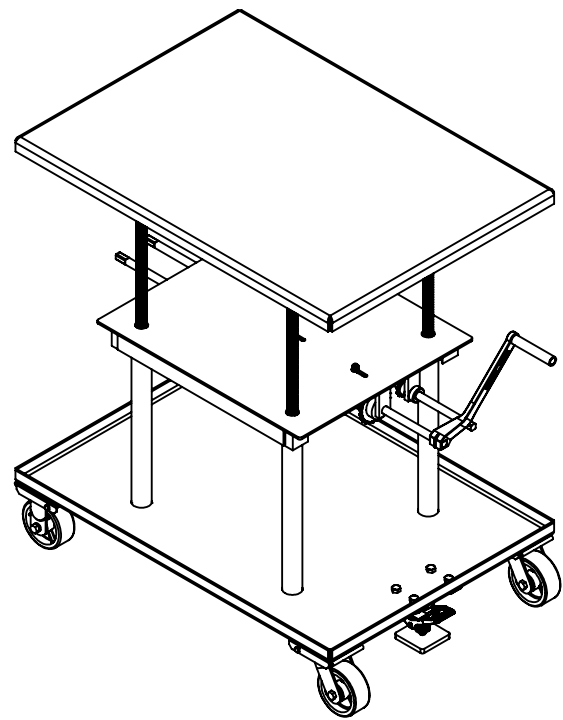
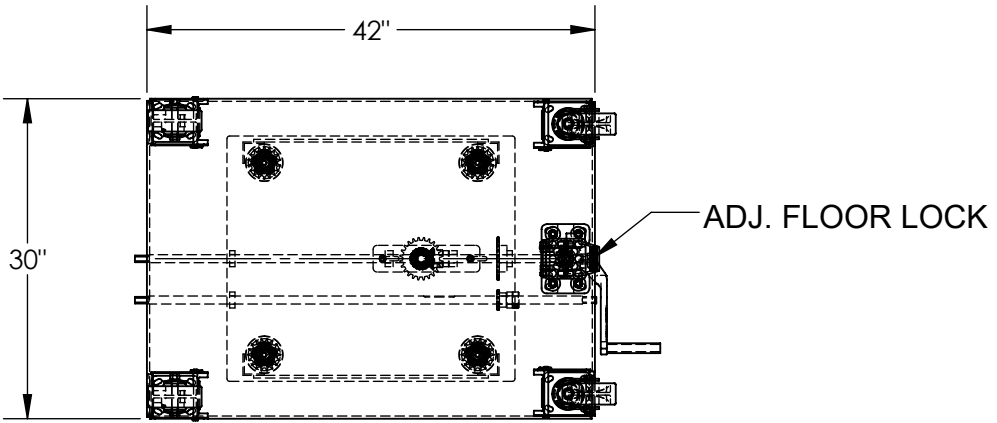
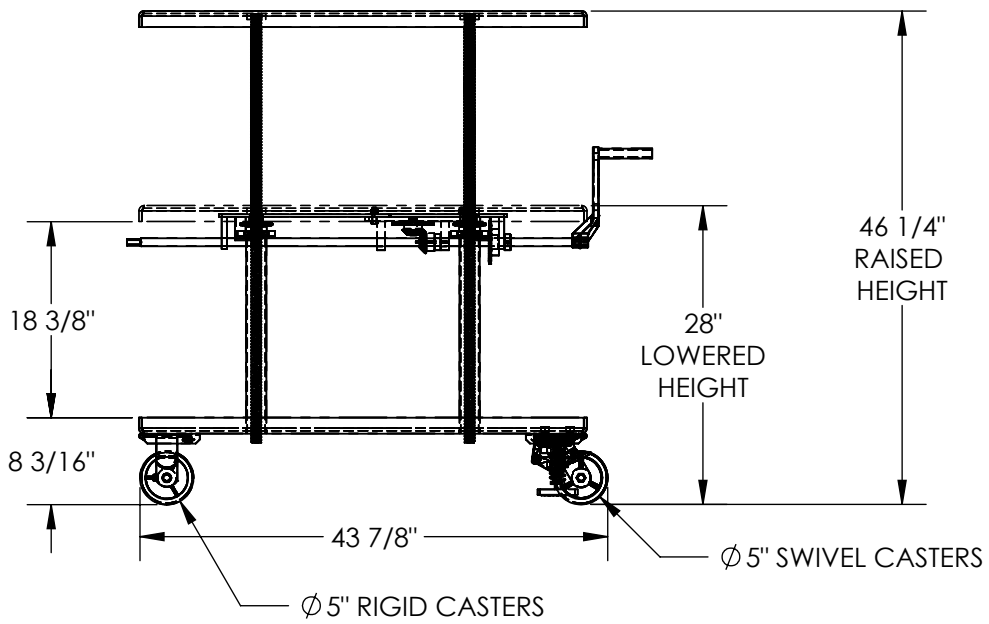

ALL GRAPHICS PROVIDED ARE FOR REFERENCE ONLY. IF CERTAIN DIMENSIONS ARE CRITICAL PLEASE VERIFY THOSE DIMENSIONS WITH YOUR SALESPERSON

DIMENSION TOLERANCE ± 1/4"

## STANDARD FEATURES

- MODEL NUMBER IS MT-3042-HP
- CAPACITY: 2,000 LBS.
- PLATFORM WIDTH : 30"
- PLATFORM LENGTH: 42"
- RAISED HEIGHT: 46 1/4"
- LOWERED HEIGHT: 28"
- HIGH-PROFILE OPERATION
- PRECISION SPROCKET/GEAR LIFTING MECH.
- LOW SPEED IS 1/8" PER CRANK
- HIGH SPEED IS 5/16" PER CRANK
- (2) - 5 X 2 POLY ON STEEL SWIVEL CASTERS
- (2) - 5 X 2 POLY ON STEEL RIGID CASTERS
- INCLUDES FLOOR LOCK
- DURABLE LIQUID PAINT BLUE FINISH

## SPECIAL FEATURES

NONE

|   |  |  |
|---|--|--|
| <b>A<br/>P<br/>P<br/>R<br/>O<br/>V<br/>A<br/>L</b>                  | I, THE UNDERSIGNED, AGREE THAT THE PRODUCT AS REPRESENTED SATISFIES DESIGN AND DIMENSION REQUIREMENTS. I ALSO ACKNOWLEDGE MY DUTY TO CONFIRM PRODUCT AND INSTALLATION COMPLIANCE WITH ALL APPLICABLE FEDERAL, STATE AND LOCAL REGULATIONS AND STANDARDS. |  |
|   | <b>UNITS REQUIRING APPROVAL DRAWINGS OR MODIFIED ARE NON-RETURNABLE</b>  |  |
|   | [ ] As drawn      [ ] As marked  |  |
|   | Signed: _____ Date: _____  |  |
| Printed Name: _____   |  |  |
| <b>LEAD TIME WILL START UPON RECEIPT OF SIGNED APPROVAL DRAWING</b> |  |  |

|                             |           |                       |
|-----------------------------|-----------|-----------------------|
| DISTRIBUTOR'S NAME:         |           | P.O.#                 |
| <b>VESTIL MANUFACTURING</b> |           | X                     |
| DRAWN BY: DEY               |           | DATE: 02/29/12        |
| REFERENCE: X                |           | SCALE: 1:18           |
| QUOTED LEAD TIME: X         | QUOTE # X | SALES: X              |
|                             |           | FILE NAME: 21-007-028 |