

LIFTING HOOKS

Clevis Hooks

For use with Grade 80 or Grade 100 Chain Slings



- Manufactured to exceed all ASME B30.20 and OSHA regulations.
- Powder coat painted safety yellow for increased visibility.
- **ALL** hooks shipped with proof load certification paperwork.
- Durable construction ideally suited to jobsite or warehouse use.
- Proof tested at 2 times working load limit.
- Extra heavy duty formed stainless latch.
- Large over-sized hook opening.
- Made in U.S.A.

 Prop 65 – See Page 112

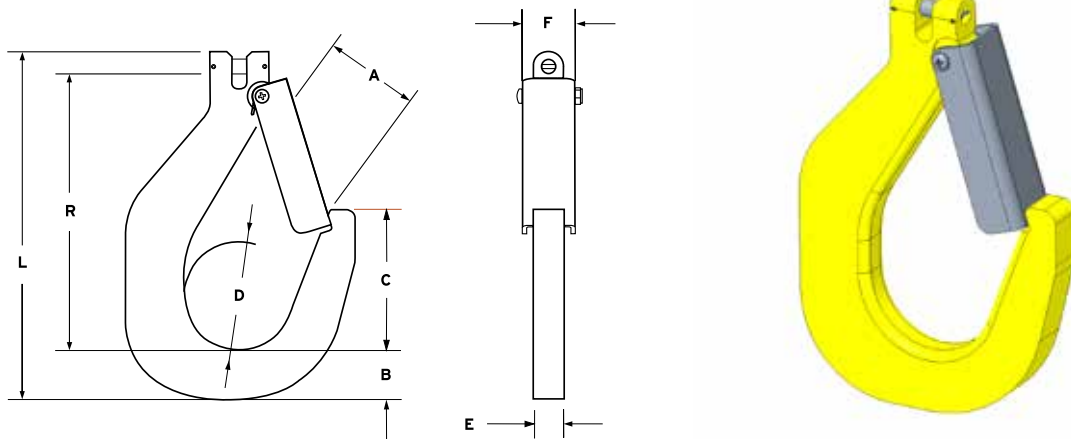

Working Load Limit in Pounds*	Part Number	Chain Size (in/mm)	A	B	C	D	E	F	L	R	Weight per Each	Latch Kit P/N
3,200	25843	7/32 6	2.4	1.25	3.55	2.75	0.75	1.4	8.8	7	5	23889
4,300	25842	1/4 (9/32) 7	2.4	1.25	3.55	2.75	0.75	1.4	8.8	7	5	23889