

OFFSET STEEL SAFETY BOLLARD - OBOL-35-4.5

APPROX WEIGHT: 33.10 lbs.
DOES NOT INCLUDE WEIGHT OF POWER OR PACKAGING!!!

ANY ADDITIONS, DELETIONS, OR OMISSIONS MUST BE CORRECTED ON THIS DRAWING AS THIS DRAWING WILL BE CONSIDERED ALL INCLUSIVE

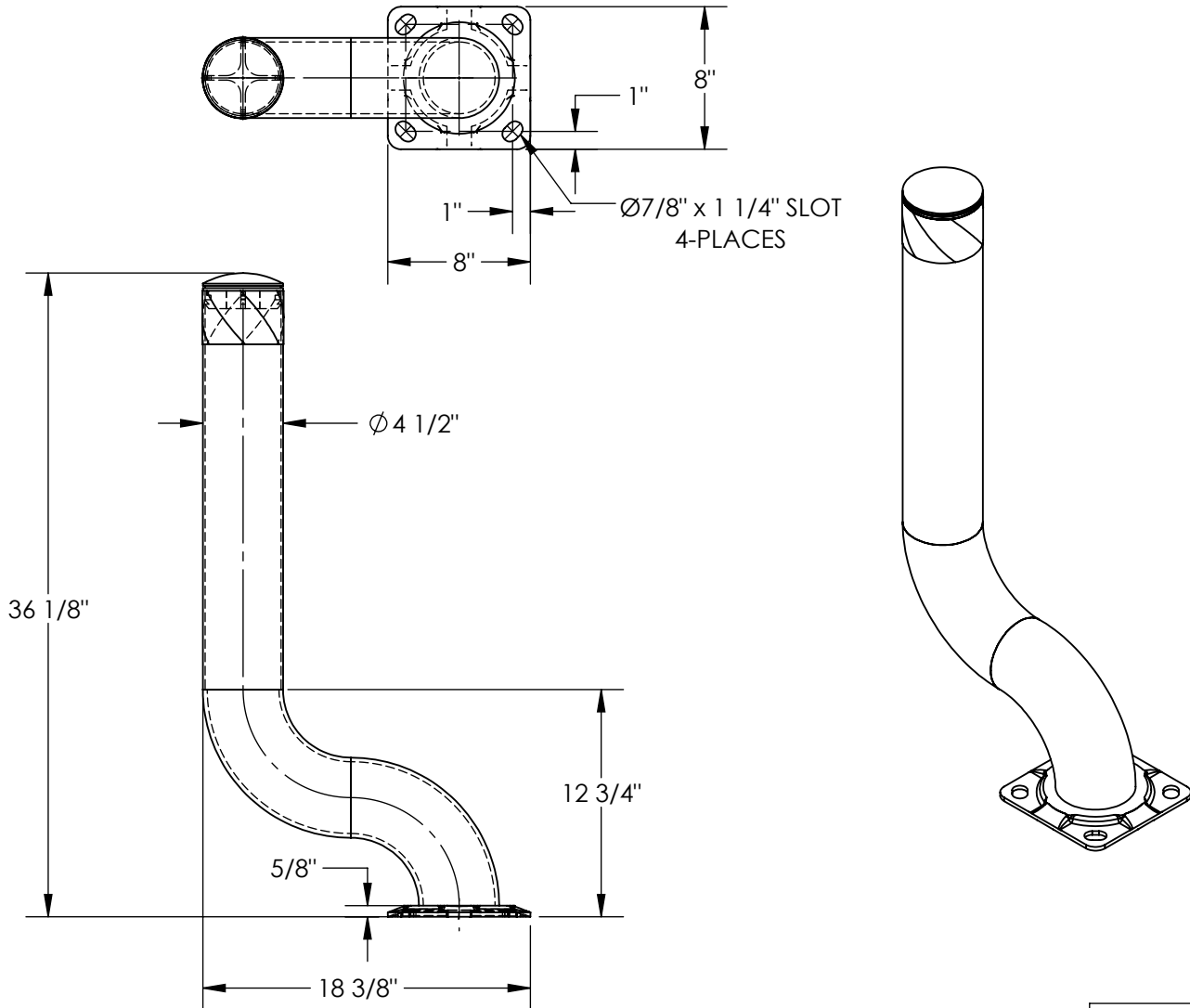

ALL GRAPHICS PROVIDED ARE FOR REFERENCE ONLY. IF CERTAIN DIMENSIONS ARE CRITICAL PLEASE VERIFY THOSE DIMENSIONS WITH YOUR SALESPERSON

STANDARD FEATURES

- MODEL NUMBER IS OBOL-35-4.5
- OVERALL WIDTH IS 8"
- OVERALL LENGTH IS 18 3/8"
- OVERALL HEIGHT IS 36 1/8"
- MACHINE GUARD PIPE DIA IS 4 1/2"
- LAG DOWN MOUNTING PLATE: 5/8" X 8" X 8"
- WITH MOUNTING SLOTS 7/8" X 1 1/4"
- FOR 3/4" DIA ANCHOR BOLTS (SOLD SEPARATELY)
- BLACK & YELLOW SAFETY STRIPES
- BLACK REMOVABLE PLASTIC CAP
- TOUGH BAKED IN POWDER COATED YELLOW FINISH
- ALL STEEL CONSTRUCTION (ASTM A-36 MIN.) WITH WELDING TO MEET AWS
- WARNING: CHECK APPLICABLE STATE & LOCAL LAWS FOR YOUR AREA

SPECIAL FEATURES

NONE

FOR INTERNAL USE ONLY PROJECT SIGN OFF	
SALES	
ENG.	
FAB.	
POWER	

DIMENSION TOLERANCE ± 1/4"

APPROVAL	I, THE UNDERSIGNED, AGREE THAT THE PRODUCT AS REPRESENTED SATISFIES DESIGN AND DIMENSION REQUIREMENTS. I ALSO ACKNOWLEDGE MY DUTY TO CONFIRM PRODUCT AND INSTALLATION COMPLIANCE WITH ALL APPLICABLE FEDERAL, STATE AND LOCAL REGULATIONS AND STANDARDS.	
	ANY MODIFIED UNITS ARE NON-RETURNABLE	
	[] As drawn [] As marked	
	Signed: _____ Date: _____	
Printed Name: _____		
LEAD TIME WILL START UPON RECEIPT OF SIGNED APPROVAL DRAWING		

DISTRIBUTOR'S NAME:		P.O.#
VESTIL MANUFACTURING		X
		W.O.#
DRAWN BY: KC		X
DATE: 8/19/15		SALES: X
REFERENCE: X	SCALE: 1:10	FILE NAME:
QUOTED LEAD TIME: X	QUOTE # X	44-007-049