

PORTABLE ADJ. HEIGHT WORKER STAND - PAHT-H-2448

APPROX WEIGHT: 80.96 lbs.
 DOES NOT INCLUDE WEIGHT OF POWER OR PACKAGING!!!

ANY ADDITIONS, DELETIONS, OR OMISSIONS MUST BE CORRECTED ON THIS DRAWING AS THIS DRAWING WILL BE CONSIDERED ALL INCLUSIVE

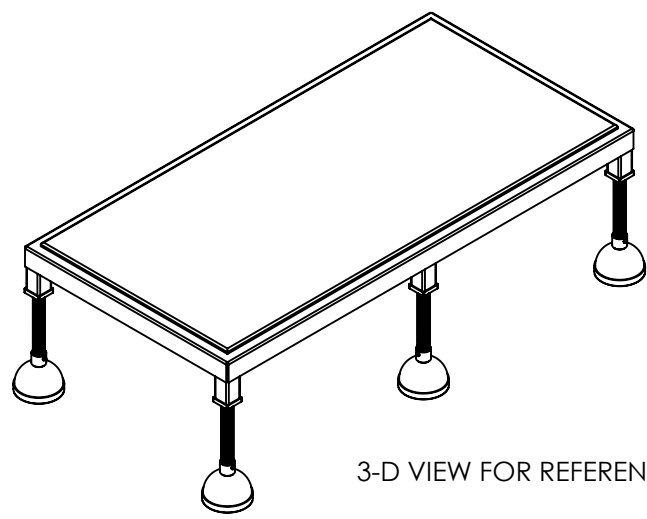
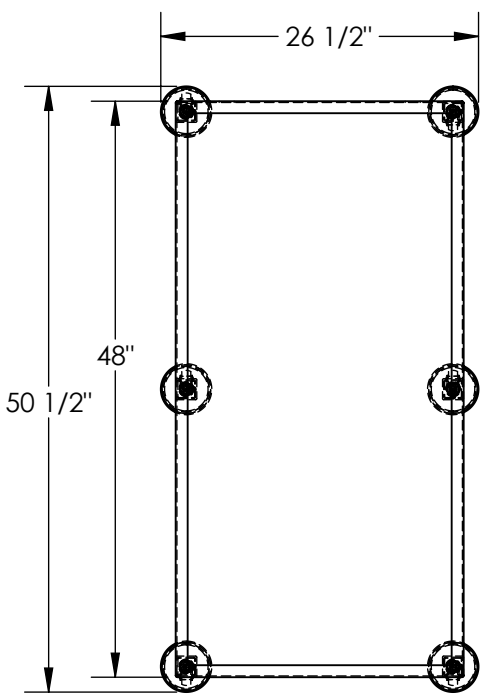

3-D VIEW FOR REFERENCE

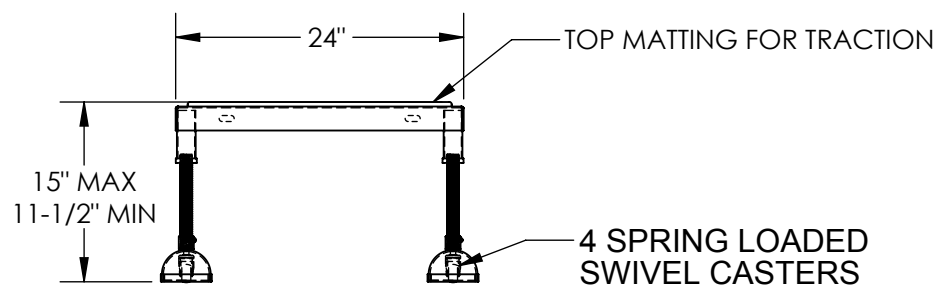

DIMENSION TOLERANCE ± 1/4"

FOR INTERNAL USE ONLY PROJECT SIGN OFF	
SALES	
ENG.	
FAB.	
POWER	

ALL GRAPHICS PROVIDED ARE FOR REFERENCE ONLY. IF CERTAIN DIMENSIONS ARE CRITICAL PLEASE VERIFY THOSE DIMENSIONS WITH YOUR SALESPERSON

STANDARD FEATURES

- MODEL NUMBER IS PAHT-H-2448
- CAPACITY IS 500 LBS
- OVERALL WIDTH IS 26 1/2"
- USABLE WIDTH IS 24"
- OVERALL LENGTH IS 50 1/2"
- USABLE LENGTH IS 48"
- OVERALL HEIGHT IS 11-1/2 THRU 15"
- 6 ADJUSTABLE LENGTH LEGS
- 6 SPRING LOADED SWIVEL CASTERS
- TOUGH BAKED IN POWDER COATED YELLOW FINISH

APPROVAL

I, THE UNDERSIGNED, AGREE THAT THE PRODUCT AS REPRESENTED SATISFIES DESIGN AND DIMENSION REQUIREMENTS. I ALSO ACKNOWLEDGE MY DUTY TO CONFIRM PRODUCT AND INSTALLATION COMPLIANCE WITH ALL APPLICABLE FEDERAL, STATE AND LOCAL REGULATIONS AND STANDARDS.

ANY MODIFIED UNITS ARE NON-RETURNABLE

[] As drawn [] As marked

Signed: _____ Date: _____

Printed Name: _____

LEAD TIME WILL START UPON RECEIPT OF SIGNED APPROVAL DRAWING

DISTRIBUTOR'S NAME:		P.O.#
VESTIL MANUFACTURING		X
		W.O.#
DRAWN BY: MTS		X
DATE: 03/26/13		SALES: X
REFERENCE: X	SCALE: 1:16	FILE NAME:
QUOTED LEAD TIME: X	QUOTE # X	14-007-190