

PORTABLE ADJ. HEIGHT WORKER STAND - PAHW-H-1924

APPROX WEIGHT: 43.83 lbs.
 DOES NOT INCLUDE WEIGHT OF POWER OR PACKAGING!!!

ANY ADDITIONS, DELETIONS, OR OMISSIONS MUST BE CORRECTED ON THIS DRAWING AS THIS DRAWING WILL BE CONSIDERED ALL INCLUSIVE

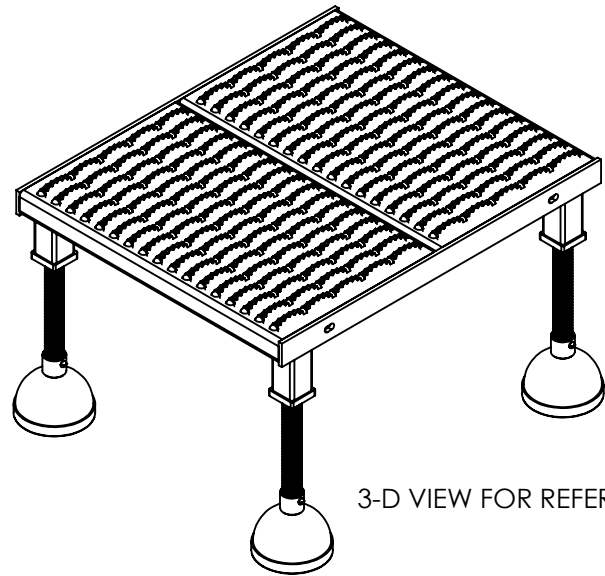
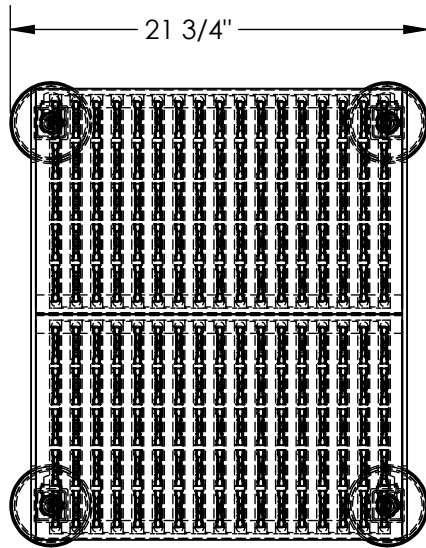

3-D VIEW FOR REFERENCE

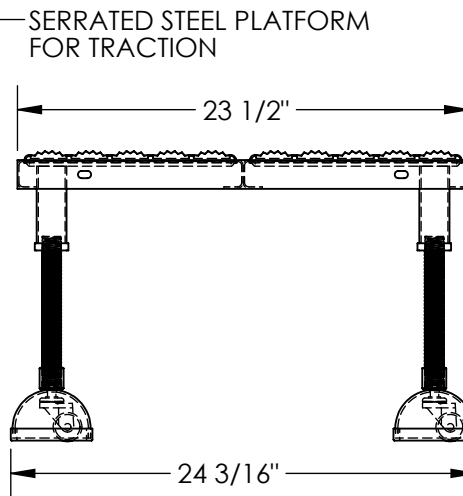
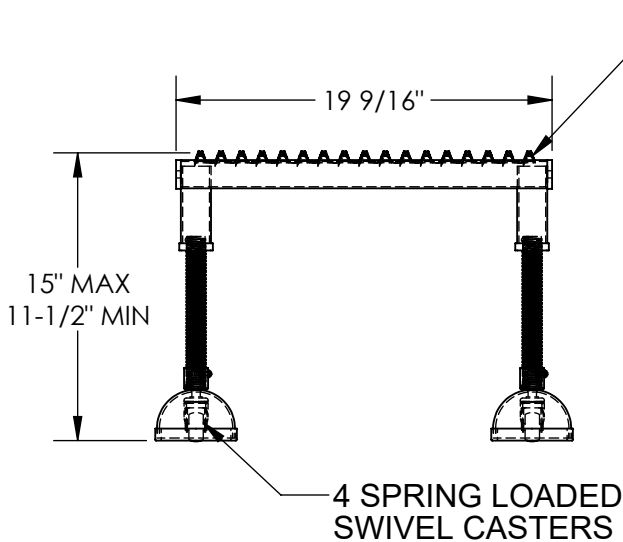

DIMENSION TOLERANCE $\pm 1/4"$

ALL GRAPHICS PROVIDED ARE FOR REFERENCE ONLY. IF CERTAIN DIMENSIONS ARE CRITICAL PLEASE VERIFY THOSE DIMENSIONS WITH YOUR SALESPERSON

STANDARD FEATURES

- MODEL NUMBER IS PAHW-H-1924
- CAPACITY IS 500 LBS
- OVERALL WIDTH IS 21 3/4"
- USABLE WIDTH IS 19 9/16"
- OVERALL LENGTH IS 24 3/16"
- USABLE LENGTH IS 23 1/2"
- OVERALL HEIGHT IS 11-1/2" THRU 15"
- 4 ADJUSTABLE LENGTH LEGS
- 4 SPRING LOADED SWIVEL CASTERS
- TOUGH BAKED IN POWDER COATED YELLOW FINISH

**A
P
P
R
O
V
A
L**

I, THE UNDERSIGNED, AGREE THAT THE PRODUCT AS REPRESENTED SATISFIES DESIGN AND DIMENSION REQUIREMENTS. I ALSO ACKNOWLEDGE MY DUTY TO CONFIRM PRODUCT AND INSTALLATION COMPLIANCE WITH ALL APPLICABLE FEDERAL, STATE AND LOCAL REGULATIONS AND STANDARDS.

UNITS REQUIRING APPROVAL DRAWINGS OR MODIFIED ARE NON-RETURNABLE

[] As drawn [] As marked

Signed: _____ Date: _____

Printed Name: _____

LEAD TIME WILL START UPON RECEIPT OF SIGNED APPROVAL DRAWING

DISTRIBUTOR'S NAME:		P.O.#
VESTIL MANUFACTURING		X
		W.O.#
DRAWN BY: MTS		X
DATE: 3/26/13		SALES:
REFERENCE: X		X
SCALE: 1:10		FILE NAME:
QUOTED LEAD TIME: X		14-007-173
QUOTE #		
X		