

STRETCH WRAPER ALUMINUM QUICK LIFT-PEL-100A-D3-SWA

APPROX WEIGHT: 205.85 lbs.
 DOES NOT INCLUDE WEIGHT OF POWER OR PACKAGING!!!

ANY ADDITIONS, DELETIONS, OR OMISSIONS MUST BE CORRECTED ON THIS DRAWING AS THIS DRAWING WILL BE CONSIDERED ALL INCLUSIVE

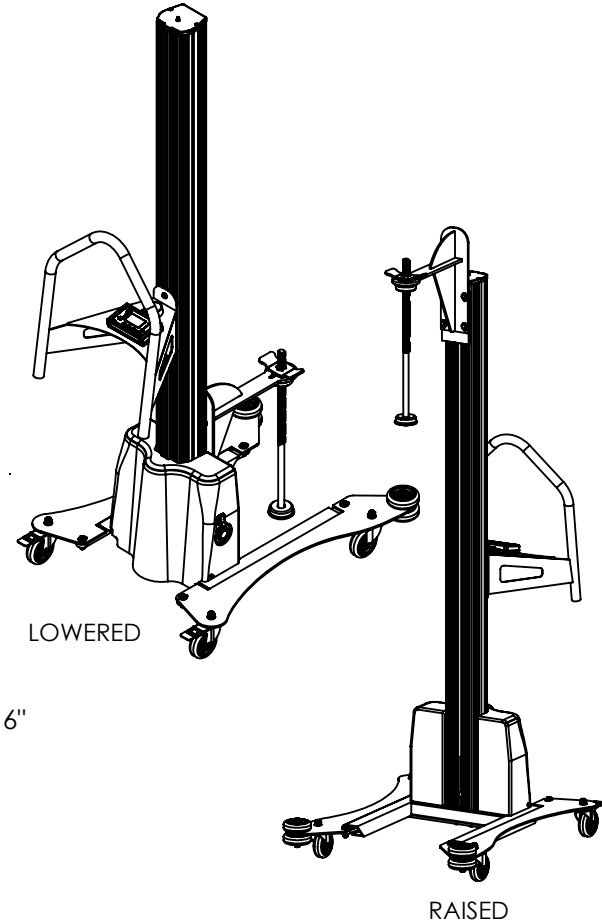
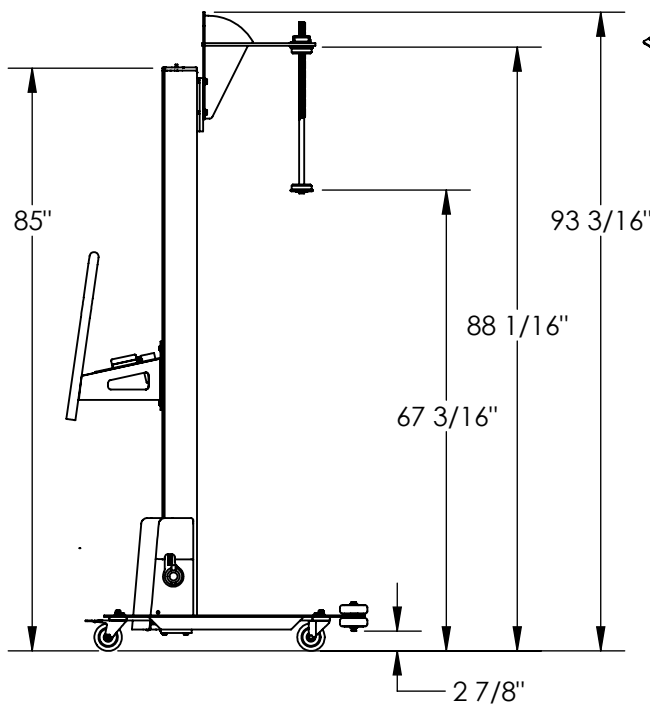
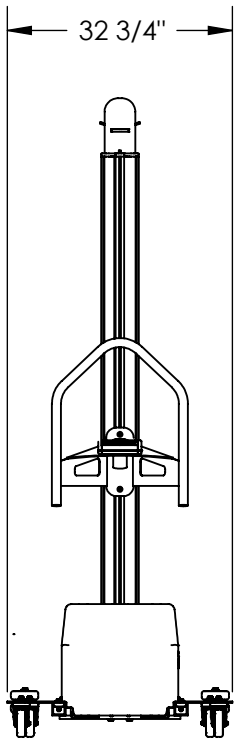
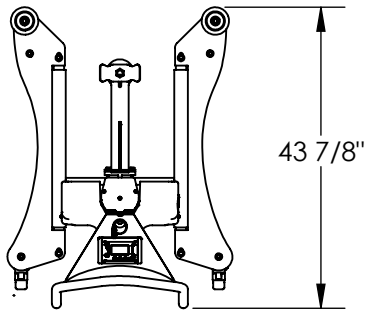

ALL GRAPHICS PROVIDED ARE FOR REFERENCE ONLY. IF CERTAIN DIMENSIONS ARE CRITICAL PLEASE VERIFY THOSE DIMENSIONS WITH YOUR SALESPERSON

DIMENSION TOLERANCE ± 1/4"

STANDARD FEATURES

- MODEL NUMBER IS PEL-100A-D3-SWA
- ALUMINUM AND STEEL CONSTRUCTION
- DURABLE BAKED IN POWDER COATED BLUE FINISH
- OVERALL WIDTH IS 32 3/4"
- OVERALL LENGTH IS 43 7/8"
- 24V DC POWER WITH ON BOARD CHARGER
- Ø4" POLY ON POLY STEM CASTER
- 2 SWIVEL W/BRAKE & 2 SWIVEL

SPECIAL FEATURES

NONE

APPROVAL

I, THE UNDERSIGNED, AGREE THAT THE PRODUCT AS REPRESENTED SATISFIES DESIGN AND DIMENSION REQUIREMENTS. I ALSO ACKNOWLEDGE MY DUTY TO CONFIRM PRODUCT AND INSTALLATION COMPLIANCE WITH ALL APPLICABLE FEDERAL, STATE AND LOCAL REGULATIONS AND STANDARDS.
UNITS REQUIRING APPROVAL DRAWINGS OR MODIFIED ARE NON-RETURNABLE
 As drawn As marked

Signed: _____ Date: _____

Printed Name: _____

LEAD TIME WILL START UPON RECEIPT OF SIGNED APPROVAL DRAWING

DISTRIBUTOR'S NAME:		P.O.#
VESTIL MANUFACTURING		X
DRAWN BY: DEY		W.O.#
DATE: 08/06/10		X
REFERENCE: X	SCALE: 1:28	SALES: X
QUOTED LEAD TIME: X	QUOTE # X	FILE NAME:
		20-007-114