

# STRETCH WRAPER ALUMINUM QUICK LIFT-PEL-88A-D3-SWA

APPROX WEIGHT: 196.95 lbs.  
 DOES NOT INCLUDE WEIGHT OF POWER OR PACKAGING!!!

\*\*\*ANY ADDITIONS, DELETIONS, OR OMISSIONS MUST BE CORRECTED ON THIS DRAWING AS THIS DRAWING WILL BE CONSIDERED ALL INCLUSIVE\*\*\*

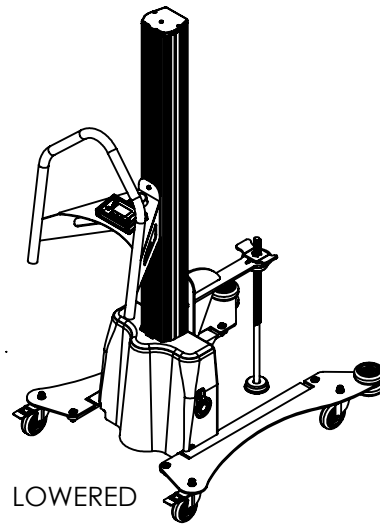
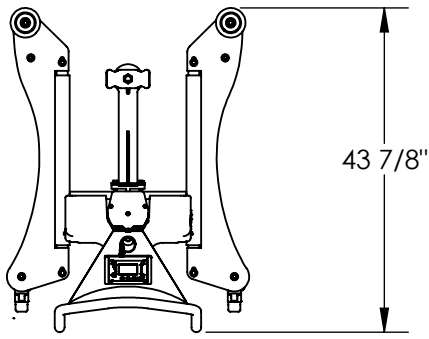

LOWERED

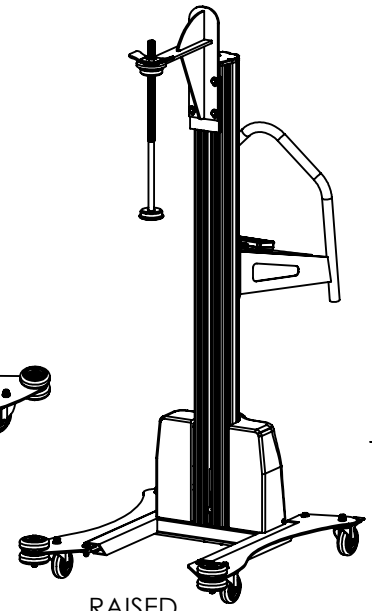

RAISED

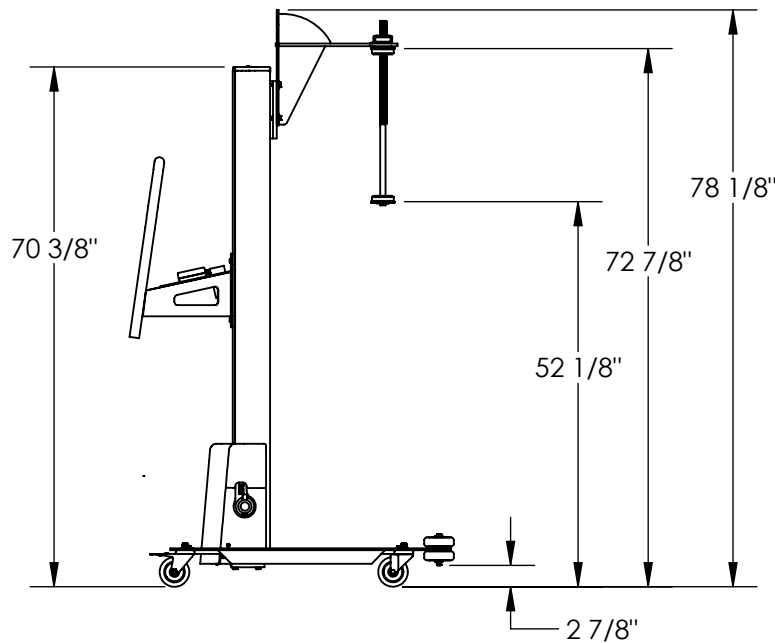
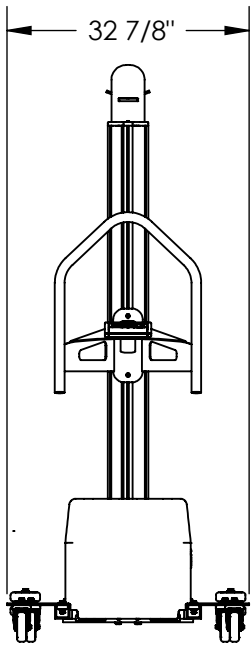

ALL GRAPHICS PROVIDED ARE FOR REFERENCE ONLY. IF CERTAIN DIMENSIONS ARE CRITICAL PLEASE VERIFY THOSE DIMENSIONS WITH YOUR SALESPERSON

DIMENSION TOLERANCE  $\pm 1/4"$

## STANDARD FEATURES

- MODEL NUMBER IS PEL-88A-D3-SWA
- ALUMINUM AND STEEL CONSTRUCTION
- DURABLE BAKED IN POWDER COATED BLUE FINISH
- OVERALL WIDTH IS 32 7/8"
- OVERALL LENGTH IS 43 7/8"
- 24V DC POWER WITH ON BOARD CHARGER
- Ø 4" POLY ON POLY STEM CASTERS
- 2 SWIVEL W/BRAKE & 2 SWIVEL

## SPECIAL FEATURES

NONE

APPROVAL

I, THE UNDERSIGNED, AGREE THAT THE PRODUCT AS REPRESENTED SATISFIES DESIGN AND DIMENSION REQUIREMENTS. I ALSO ACKNOWLEDGE MY DUTY TO CONFIRM PRODUCT AND INSTALLATION COMPLIANCE WITH ALL APPLICABLE FEDERAL, STATE AND LOCAL REGULATIONS AND STANDARDS.  
**UNITS REQUIRING APPROVAL DRAWINGS OR MODIFIED ARE NON-RETURNABLE**  
 As drawn       As marked

Signed: \_\_\_\_\_ Date: \_\_\_\_\_

Printed Name: \_\_\_\_\_

LEAD TIME WILL START UPON RECEIPT OF SIGNED APPROVAL DRAWING

DISTRIBUTOR'S NAME:		P.O.#
VESTIL MANUFACTURING		X
DRAWN BY: DEY		W.O.#
DATE: 08/10/10		X
REFERENCE: X	SCALE: 1:26	SALES: X
QUOTED LEAD TIME: X	QUOTE # X	FILE NAME:
		20-007-113