

# CUTTER - PKG-C-1

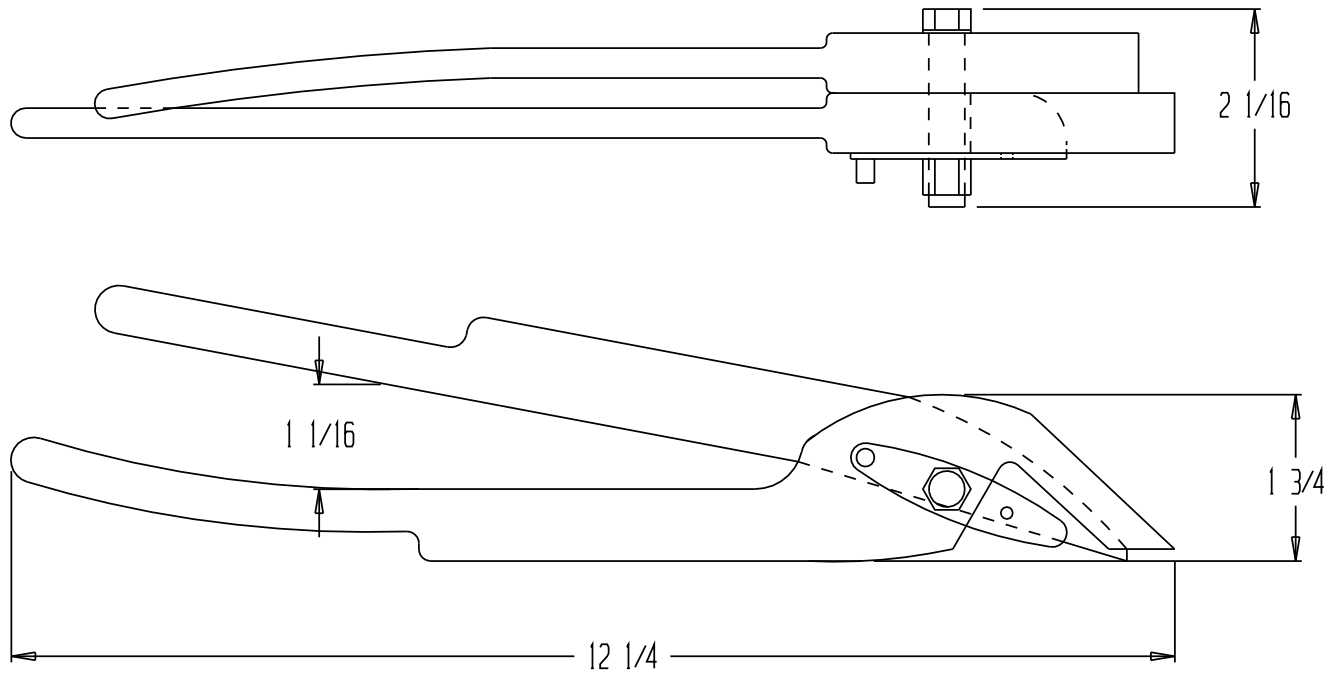

All graphics provided are for reference only.  
If certain dimensions are critical please  
verify those dimensions with your salesperson

## STANDARD FEATURES

MODEL NUMBER: PKG-C-1  
 OVERALL SIZE: 12 1/4" W x 2 3/4" H  
 STRAPPING WIDTH: 3/8" TO 1"  
 MATERIAL: STEEL  
 COLOR: BLACK  
 HANDLE WHEN OPEN: 4 7/8" W  
 SPECIAL FEATURES  
 NONE

PRODUCTION WILL START UPON  
RECEIPT OF SIGNED APPROVAL  
DRAWING

\*\*SPECIAL UNITS ARE NON-RETURNABLE  
 \*AVAILABLE AT ADDITIONAL COSTS

FOR INTERNAL USE ONLY PROJECT SIGN OFF		I, THE UNDERSIGNED, AGREE THAT THE PRODUCT AS REPRESENTED SATISFIES DESIGN & DIMENSION REQUIREMENTS. I ALSO ACKNOWLEDGE MY DUTY TO CONFIRM PRODUCT & INSTALLATION COMPLIANCE WITH ALL APPLICABLE FEDERAL, STATE AND LOCAL REGULATIONS & STANDARDS. <b>ANY MODIFIED UNITS ARE NON-RETURNABLE</b> ( ) As drawn ( ) As marked Signed: _____ Date: _____ Printed Name: _____ LEAD TIME WILL START UPON RECEIPT OF SIGNED APPROVAL DRAWING
SALES		
ENG		
FAB.		
POWER		
DISTRIBUTOR'S NAME: <b>VESTIL MANUFACTURING</b>		P.O.#: -
DRAWN BY: CD	DATE: 11-21-07	W.D.#: -
REFERENCE: -	SCALE: 1:2	SALES: -
QUOTED LEADTIME: -	QUOTE #: -	DRWG./FILE NAME: PKG-C-1