

HEAVY DUTY SLAB DOLLY - PLDL-HD-4-10PN

APPROX WEIGHT: 25.73 lbs.
DOES NOT INCLUDE WEIGHT OF POWER OR PACKAGING!!!

*** ANY ADDITIONS, DELETIONS, OR OMISSIONS MUST BE CORRECTED ON THIS DRAWING AS THIS DRAWING WILL BE CONSIDERED ALL INCLUSIVE ***

ALL GRAPHICS PROVIDED ARE FOR REFERENCE ONLY. IF CERTAIN DIMENSIONS ARE CRITICAL PLEASE VERIFY THOSE DIMENSIONS WITH YOUR SALESPERSON

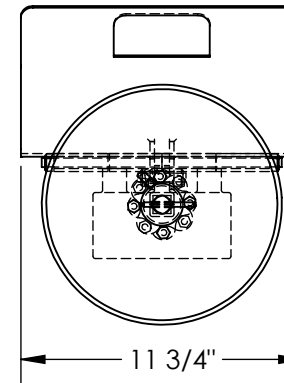
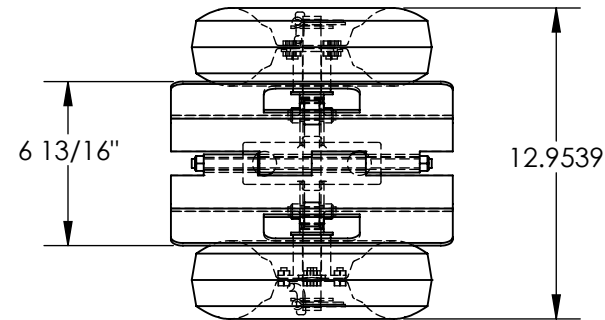
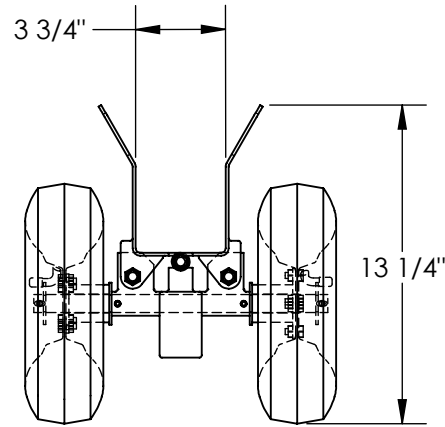

DIMENSION TOLERANCE $\pm 1/4$ "

STANDARD FEATURES

- MODEL NUMBER IS PLDL-HD-4-10PN
- CAPACITY IS: 750 LBS.
- OVERALL WIDTH IS: 12.9539
- MAX. USABLE WIDTH IS 3 3/4"
- OVERALL LENGTH IS: 11 3/4"
- OVERALL HEIGHT IS: 13 1/4"
- DOLLY AUTOMATICALLY CLAMPS WHEN WEIGHT IS APPLIED
- STRAP (NOT INCLUDED) CAN BE HOOKED TO HAND SLOTS
- USES TWO 10" PNEUMATIC WHEELS
- TOUGH BAKED IN POWDER COAT BLUE FINISH

SPECIAL FEATURES

NONE

APPROVAL

I, THE UNDERSIGNED, AGREE THAT THE PRODUCT AS REPRESENTED SATISFIES DESIGN AND DIMENSION REQUIREMENTS. I ALSO ACKNOWLEDGE MY DUTY TO CONFIRM PRODUCT AND INSTALLATION COMPLIANCE WITH ALL APPLICABLE FEDERAL, STATE AND LOCAL REGULATIONS AND STANDARDS.

UNITS REQUIRING APPROVAL DRAWINGS OR MODIFIED ARE NON-RETURNABLE

As drawn As marked

Signed: _____ Date: _____

Printed Name: _____

LEAD TIME WILL START UPON RECEIPT OF SIGNED APPROVAL DRAWING

| | | |
|----------------------|---------|----------------|
| DISTRIBUTOR'S NAME: | | P.O.# |
| VESTIL MANUFACTURING | | X |
| DRAWN BY: TAL | | DATE: 9/4/2020 |
| REFERENCE: X | | SCALE: 1:8 |
| QUOTED LEAD TIME: X | QUOTE # | FILE NAME: |
| X | X | 16-007-514-004 |
| | | SALES: X |
| | | W.O.# |
| | | X |