

ELECTRIC STACKER, FIXED FORKS - PMC-SNM-FF-62

*** ANY ADDITIONS, DELETIONS, OR OMISSIONS MUST BE CORRECTED ON THIS DRAWING AS THIS DRAWING WILL BE CONSIDERED ALL INCLUSIVE ***
 ALL GRAPHICS PROVIDED ARE FOR REFERENCE ONLY. IF CERTAIN DIMENSIONS ARE CRITICAL PLEASE VERIFY THOSE DIMENSIONS WITH YOUR SALESPERSON

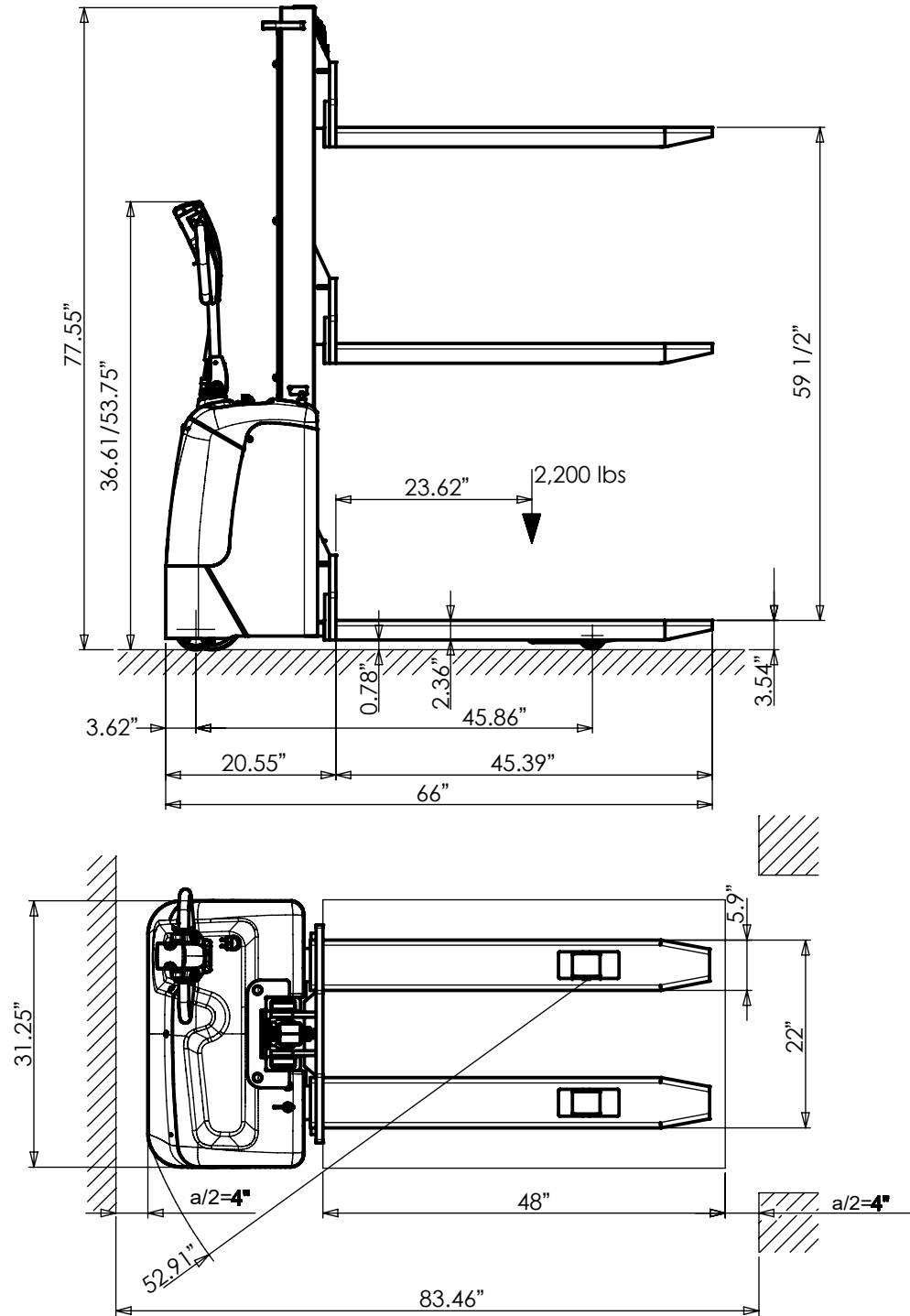

SPECIFICATIONS

MODEL NO: PMC-SNM-FF-62
 CAPACITY (UDL): 2,200 LBS
 LIFT HEIGHT: 59 1/2"
 LOWERED HEIGHT: 3 1/2"
 FIXED FORKS OVER FIXED LEGS
 OVERALL MAST HEIGHT: 77 1/2"
 DRIVE WHEEL: Ø7 5/16" X 2"
 FRONT WHEEL: Ø3.2" X 2.75"
 STABILIZER WHEEL: Ø4.92" X 1.77"
 DRIVE MOTOR: DC24V/0.35Kw
 LIFT MOTOR: DC24V/2.2Kw
 BATTERY: (2) 12V/70~80Ah
 TRAVEL SPEED W/ LOAD: 2.2m/h
 TRAVEL SPEED W/O LOAD: 2.5m/h
 LIFT SPEED W/ LOAD: 4.3"/s
 LIFT SPEED W/O LOAD: 7.08"/s
 TOUGH BAKED IN POWDER COATED
 BLACK & GREEN FINISH

FOR INTERNAL USE ONLY PROJECT SIGN OFF	
SALES	
ENG.	
FAB.	
POWER	

DIMENSION TOLERANCE ± 1/2"

APPROVAL

I, THE UNDERSIGNED, AGREE THAT THE PRODUCT AS REPRESENTED SATISFIES DESIGN AND DIMENSION REQUIREMENTS. I ALSO ACKNOWLEDGE MY DUTY TO CONFIRM PRODUCT AND INSTALLATION COMPLIANCE WITH ALL APPLICABLE FEDERAL, STATE AND LOCAL REGULATIONS AND STANDARDS.
UNITS REQUIRING APPROVAL DRAWINGS OR MODIFIED ARE NON-RETURNABLE
 As drawn As marked

Signed: _____ Date: _____

Printed Name: _____

LEAD TIME WILL START UPON RECEIPT OF SIGNED APPROVAL DRAWING

DISTRIBUTOR'S NAME:		P.O.#
VESTIL MANUFACTURING		X
DRAWN BY: TM		W.O.#
DATE: 4/2/2020		X
REFERENCE: X	SCALE: 1:2	SALES: X
QUOTED LEAD TIME: X	QUOTE #	FILE NAME:
	X	PMC-SNM-FF-62