

POWER MOVE MASTER - PMM-3000-15

APPROX WEIGHT: lbs.
DOES NOT INCLUDE WEIGHT OF POWER OR PACKAGING!!!

*** ANY ADDITIONS, DELETIONS, OR OMISSIONS MUST BE CORRECTED ON THIS DRAWING AS THIS DRAWING WILL BE CONSIDERED ALL INCLUSIVE ***
ALL GRAPHICS PROVIDED ARE FOR REFERENCE ONLY. IF CERTAIN DIMENSIONS ARE CRITICAL PLEASE VERIFY THOSE DIMENSIONS WITH YOUR SALESPERSON

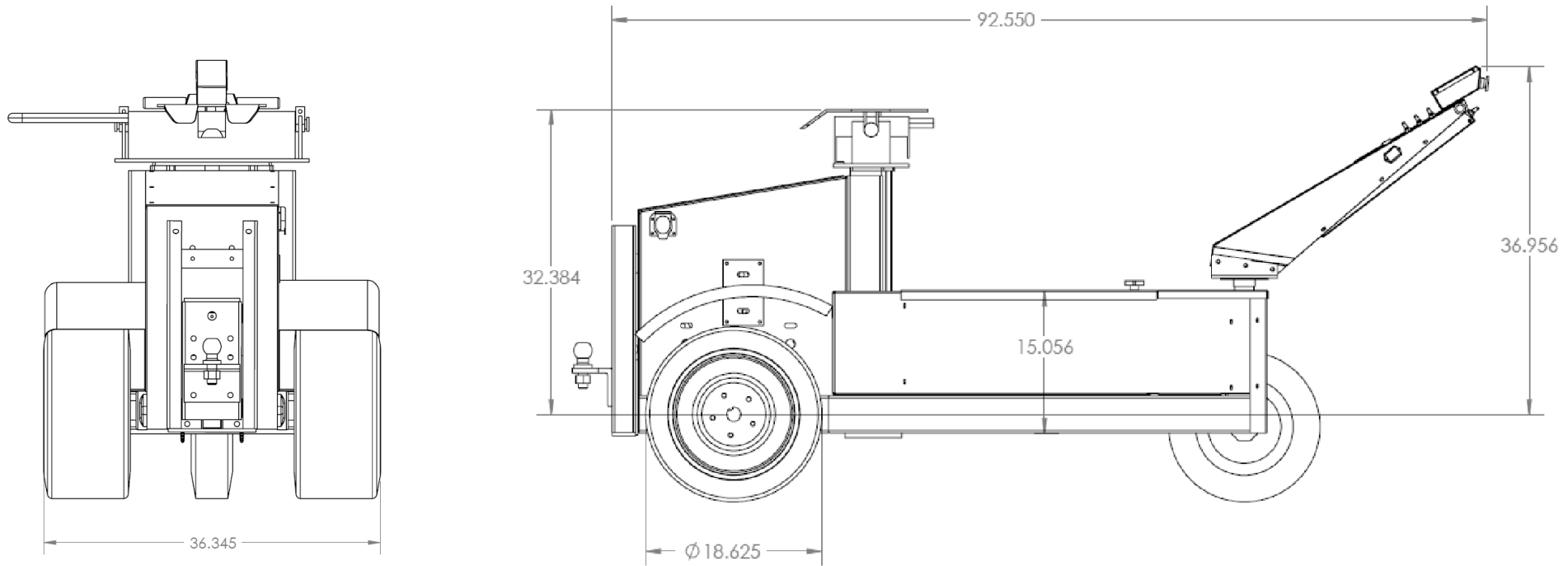

DIMENSION TOLERANCE $\pm 1/4"$

STANDARD FEATURES

MODEL NUMBER IS PMM-3000-15
 MAXIMUM PULL WEIGHT: 70,000 LBS.
 OVERALL WIDTH IS 36"
 OVERALL LENGTH IS 96"
 OVERALL HEIGHT IS 43"
 TONGUE-WEIGHT LOAD FROM
 FRONT LIFT: 3,000 LBS.
 TOP LIFT: 1,000 LBS.
 TIRE SIZE 9 1/2" X 18"
 UNIT NET WEIGHT: 2,150 LBS.

SPECIAL FEATURES

NONE

APPROVAL

I, THE UNDERSIGNED, AGREE THAT THE PRODUCT AS REPRESENTED SATISFIES DESIGN AND DIMENSION REQUIREMENTS. I ALSO ACKNOWLEDGE MY DUTY TO CONFIRM PRODUCT AND INSTALLATION COMPLIANCE WITH ALL APPLICABLE FEDERAL, STATE AND LOCAL REGULATIONS AND STANDARDS.
UNITS REQUIRING APPROVAL DRAWINGS OR MODIFIED ARE NON-RETURNABLE
 As drawn As marked

Signed: _____ Date: _____

Printed Name: _____

LEAD TIME WILL START UPON RECEIPT OF SIGNED APPROVAL DRAWING

FOR INTERNAL USE ONLY PROJECT SIGN OFF	
SALES	
ENG.	
FAB.	
POWER	

DISTRIBUTOR'S NAME:		P.O.#
VESTIL MANUFACTURING		X
DRAWN BY: X		W.O.#
DATE: XX/XX/XX		X
REFERENCE: X	SCALE: 1:48	SALES: X
QUOTED LEAD TIME: X	QUOTE #	FILE NAME:
	X	PMM-3000-15