

# POWER MOVE MASTER - PMM-3000

\*\*\*ANY ADDITIONS, DELETIONS, OR OMISSIONS MUST BE CORRECTED ON THIS DRAWING AS THIS DRAWING WILL BE CONSIDERED ALL INCLUSIVE\*\*\*

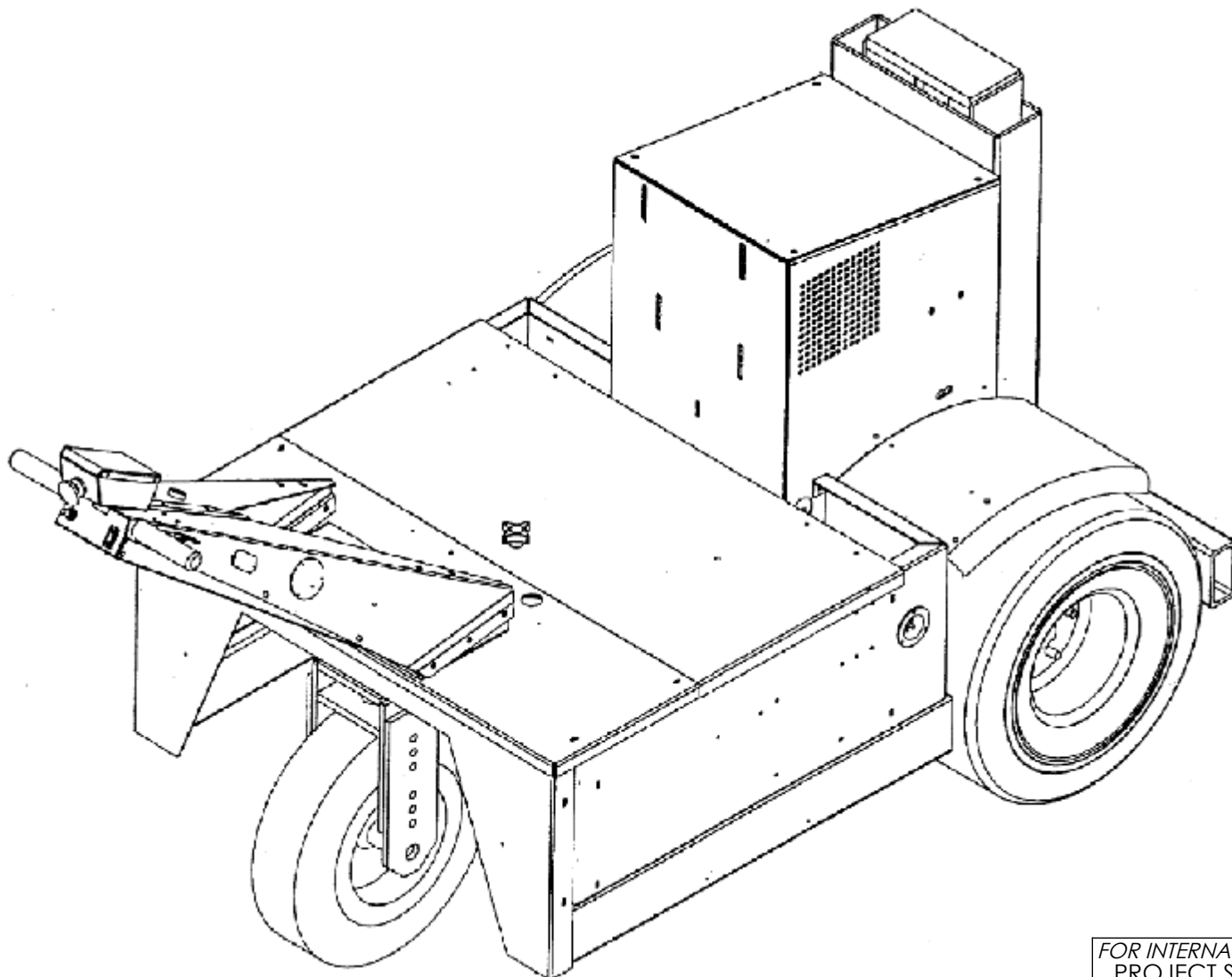

FOR INTERNAL USE ONLY  
PROJECT SIGN OFF

SALES	
ENG.	
FAB.	
POWER	

ALL GRAPHICS PROVIDED ARE FOR REFERENCE ONLY. IF CERTAIN DIMENSIONS ARE CRITICAL PLEASE VERIFY THOSE DIMENSIONS WITH YOUR SALESPERSON

DIMENSION TOLERANCE  $\pm 1/4"$

## STANDARD FEATURES

MODEL NUMBER: PMM-3000  
 MAXIMUM PULL WEIGHT: 70,000 LBS.  
 OVERALL WIDTH: 36"  
 OVERALL LENGTH: 78"  
 OVERALL HEIGHT: 43"  
 TORQUE-WEIGHT LOAD FROM FRONT LIFT: 1,000 LBS.  
 TIRE SIZE:  $\varnothing 18 \times 9 \frac{1}{2}"$   
 UNIT NET WEIGHT: 1,500 LBS.

## SPECIAL FEATURES

NONE

APPROVAL

I, THE UNDERSIGNED, AGREE THAT THE PRODUCT AS REPRESENTED SATISFIES DESIGN AND DIMENSION REQUIREMENTS. I ALSO ACKNOWLEDGE MY DUTY TO CONFIRM PRODUCT AND INSTALLATION COMPLIANCE WITH ALL APPLICABLE FEDERAL, STATE AND LOCAL REGULATIONS AND STANDARDS.  
**UNITS REQUIRING APPROVAL DRAWINGS OR MODIFIED ARE NON-RETURNABLE**  
 As drawn       As marked

Signed: \_\_\_\_\_ Date: \_\_\_\_\_

Printed Name: \_\_\_\_\_

LEAD TIME WILL START UPON RECEIPT OF SIGNED APPROVAL DRAWING

DISTRIBUTOR'S NAME:		P.O.#
VESTIL MANUFACTURING		X
DRAWN BY: X		W.O.#
DATE: XX/XX/XX		X
REFERENCE: X	SCALE: 1:48	SALES: X
QUOTED LEAD TIME: X	QUOTE #	FILE NAME:
	X	PMM-3000