

POSI-CRANK WORK PLATFORM W/ELECTRIC HYDRAULIC OPTION - POS-3648-EH-MAT APPROX WEIGHT: 430.12 lbs. DOES NOT INCLUDE WEIGHT OF POWER OR PACKAGING!!!

*** ANY ADDITIONS, DELETIONS, OR OMISSIONS MUST BE CORRECTED ON THIS DRAWING AS THIS DRAWING WILL BE CONSIDERED ALL INCLUSIVE ***
 ALL GRAPHICS PROVIDED ARE FOR REFERENCE ONLY. IF CERTAIN DIMENSIONS ARE CRITICAL PLEASE VERIFY THOSE DIMENSIONS WITH YOUR SALESPERSON

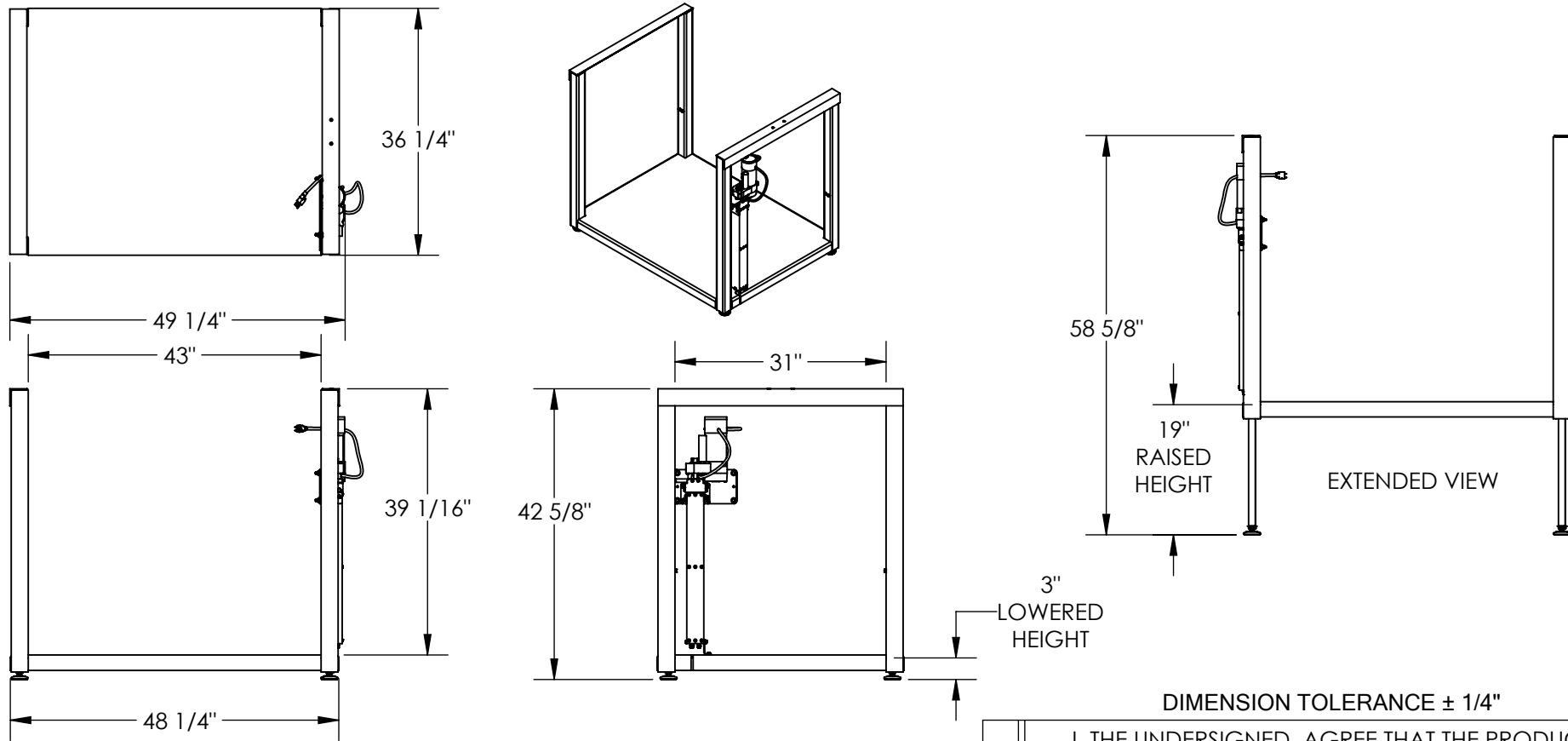

DIMENSION TOLERANCE ± 1/4"

STANDARD FEATURES

- MODEL NUMBER IS POS-3648-EH-MAT
- MAX UNIFORM CAPACITY IS 500 LBS.
- 115 VAC SINGLE PHASE POWER
- OVERALL WIDTH IS 49 1/4"
- USABLE WIDTH IS 43"
- USABLE LENGTH IS 36 1/4"
- MIN PLATFORM HEIGHT IS 3"
- MAX PLATFORM HEIGHT IS 19"
- MAX OVERALL HEIGHT IS 58 5/8"
- ERGONOMIC MAT ON TOP OF PLATFORM
- DURABLE LIQUID PAINT BLUE FINISH

SPECIAL FEATURES

NONE

A P P R O V A L

I, THE UNDERSIGNED, AGREE THAT THE PRODUCT AS REPRESENTED SATISFIES DESIGN AND DIMENSION REQUIREMENTS. I ALSO ACKNOWLEDGE MY DUTY TO CONFIRM PRODUCT AND INSTALLATION COMPLIANCE WITH ALL APPLICABLE FEDERAL, STATE AND LOCAL REGULATIONS AND STANDARDS.

UNITS REQUIRING APPROVAL DRAWINGS OR MODIFIED ARE NON-RETURNABLE

[] As drawn [] As marked

Signed: _____ Date: _____

Printed Name: _____

LEAD TIME WILL START UPON RECEIPT OF SIGNED APPROVAL DRAWING

DISTRIBUTOR'S NAME:		P.O.#
VESTIL MANUFACTURING		X
DRAWN BY: C.CLEMENS		DATE: 12/4/17
REFERENCE: X		SCALE: 1:24
QUOTED LEAD TIME: X		QUOTE # X
		SALES: X
		FILE NAME: 14-007-313-001