

# NESTABLE PANEL CART - PRCT-N

APPROX WEIGHT: 123.37 lbs.  
 DOES NOT INCLUDE WEIGHT OF POWER OR PACKAGING!!!

\*\*\* ANY ADDITIONS, DELETIONS, OR OMISSIONS MUST BE CORRECTED ON THIS DRAWING AS THIS DRAWING WILL BE CONSIDERED ALL INCLUSIVE \*\*\*

ALL GRAPHICS PROVIDED ARE FOR REFERENCE ONLY. IF CERTAIN DIMENSIONS ARE CRITICAL PLEASE VERIFY THOSE DIMENSIONS WITH YOUR SALESPERSON

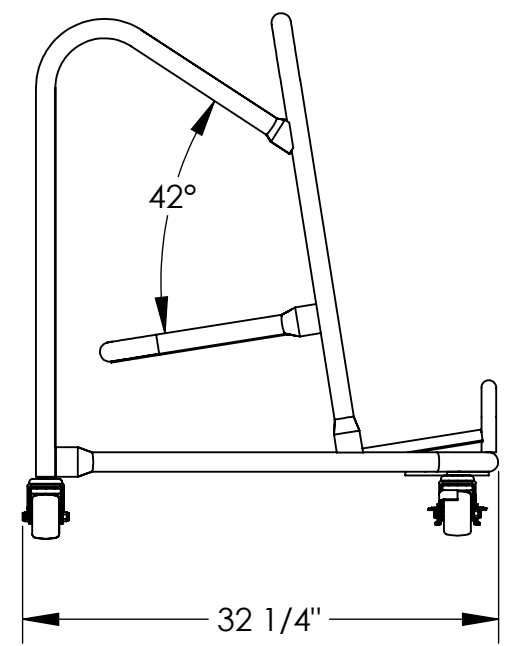
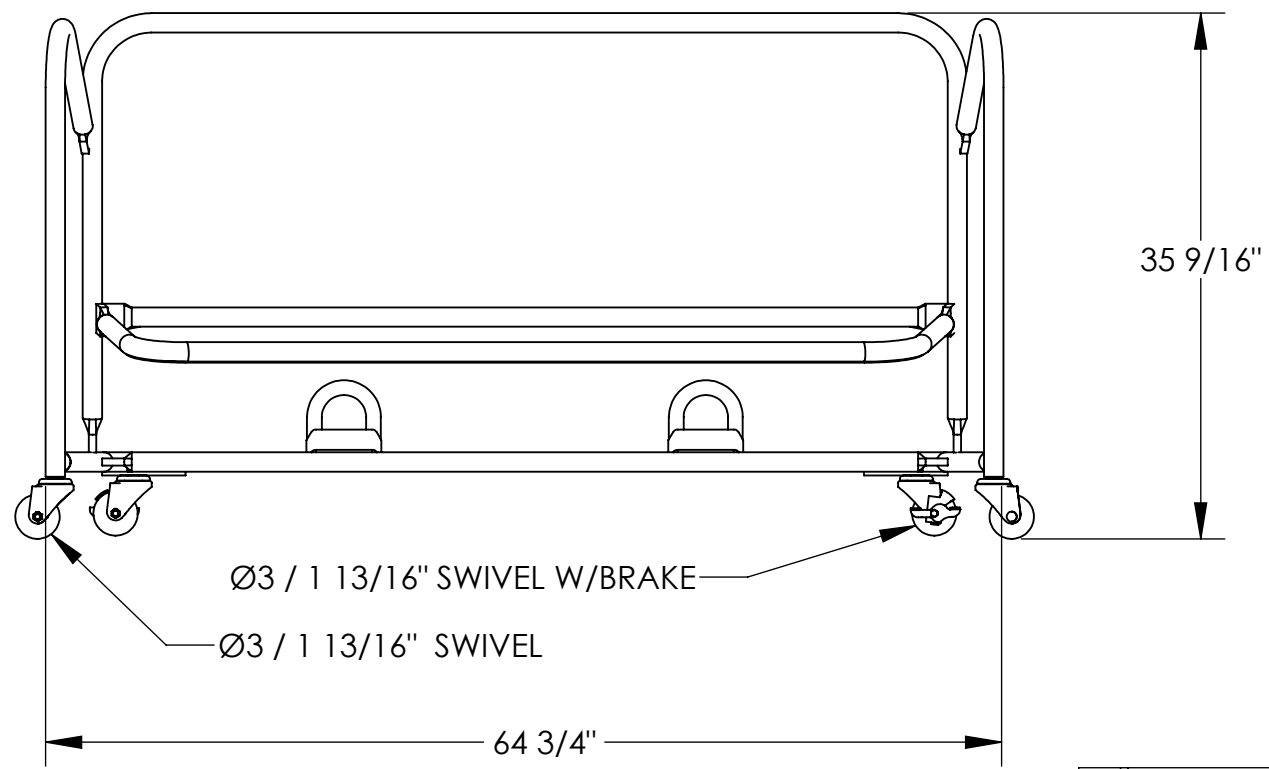

**DIMENSION TOLERANCE ± 1/4"**

## STANDARD FEATURES

- MODEL NUMBER IS PRCT-N
- CAPACITY: 2,000 LBS.
- OVERALL WIDTH IS 32 1/4"
- OVERALL LENGTH IS 64 3/4"
- OVERALL HEIGHT IS 35 9/16"
- CASTER SIZE: (4) 3" X 1 13/16"
- 2- SWIVEL W/BRAKE
- 2- SWIVEL
- TOUGH BAKED IN POWDER COAT BLUE FINISH

## SPECIAL FEATURES

NONE

**APPROVAL**

I, THE UNDERSIGNED, AGREE THAT THE PRODUCT AS REPRESENTED SATISFIES DESIGN AND DIMENSION REQUIREMENTS. I ALSO ACKNOWLEDGE MY DUTY TO CONFIRM PRODUCT AND INSTALLATION COMPLIANCE WITH ALL APPLICABLE FEDERAL, STATE AND LOCAL REGULATIONS AND STANDARDS.

**ANY MODIFIED UNITS ARE NON-RETURNABLE**

[ ] As drawn      [ ] As marked

Signed: \_\_\_\_\_ Date: \_\_\_\_\_

Printed Name: \_\_\_\_\_

*LEAD TIME WILL START UPON RECEIPT OF SIGNED APPROVAL DRAWING*

FOR INTERNAL USE ONLY PROJECT SIGN OFF	
SALES	
ENG.	
FAB.	
POWER	

DISTRIBUTOR'S NAME:		P.O.#
VESTIL MANUFACTURING		X
W.O.#		X
DRAWN BY: ND	DATE: 06/23/2005	SALES: X
REFERENCE: X	SCALE: 1:13	FILE NAME:
QUOTED LEAD TIME: X	QUOTE # X	33-007-089