

PALLET RACK LIFTING DOLLY - PRRJ-DOL

APPROX WEIGHT: 45.47 lbs.
 DOES NOT INCLUDE WEIGHT OF POWER OR PACKAGING!!!

ANY ADDITIONS, DELETIONS, OR OMISSIONS MUST BE CORRECTED ON THIS DRAWING AS THIS DRAWING WILL BE CONSIDERED ALL INCLUSIVE

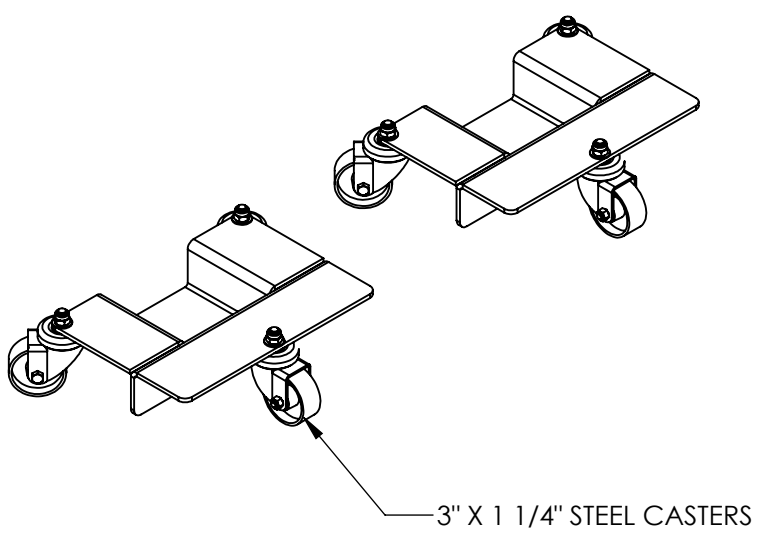
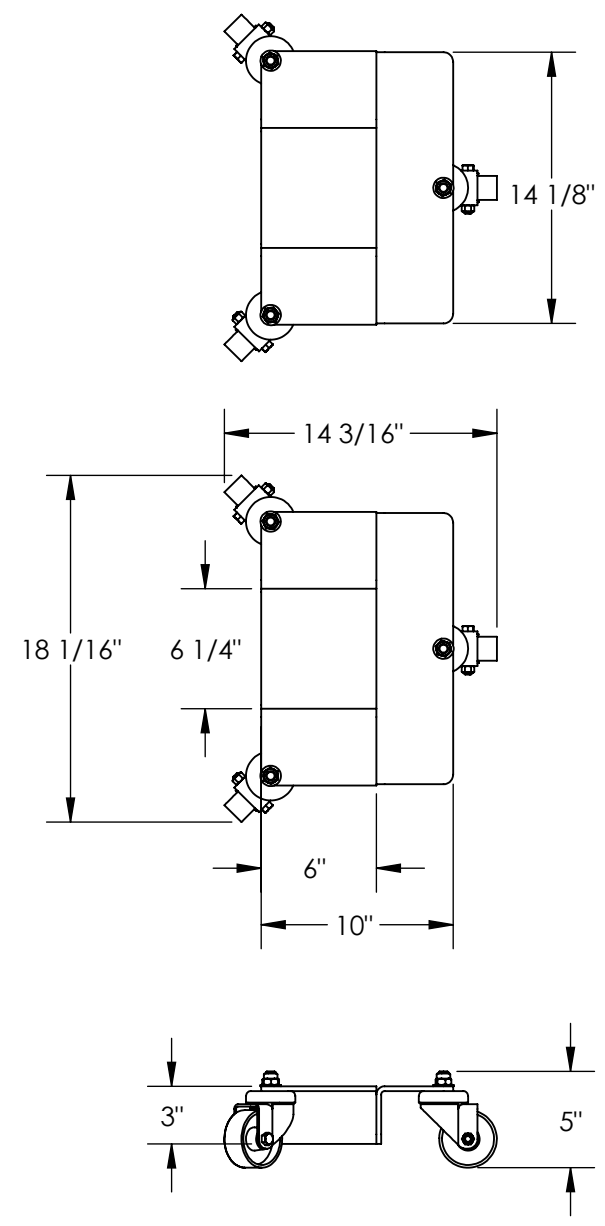

ALL GRAPHICS PROVIDED ARE FOR REFERENCE ONLY. IF CERTAIN DIMENSIONS ARE CRITICAL PLEASE VERIFY THOSE DIMENSIONS WITH YOUR SALESPERSON

STANDARD FEATURES
 MODEL NUMBER IS PRRJ-DOL
 FOR MOVING FULLY ASSEMBLED,
 EMPTY PALLET RACKING
 OVERALL WIDTH IS 14 3/16"
 USABLE WIDTH IS 6"
 OVERALL LENGTH IS 18 1/16"
 USABLE LENGTH 6 1/4"
 OVERALL HEIGHT IS 5"
 500 LBS CAPACITY EACH
 SOLD IN PAIRS
 TOUGH BAKED IN POWDER
 COATED YELLOW FINISH

SPECIAL FEATURES
 NONE

A P P R O V A L

I, THE UNDERSIGNED, AGREE THAT THE PRODUCT AS REPRESENTED SATISFIES DESIGN AND DIMENSION REQUIREMENTS. I ALSO ACKNOWLEDGE MY DUTY TO CONFIRM PRODUCT AND INSTALLATION COMPLIANCE WITH ALL APPLICABLE FEDERAL, STATE AND LOCAL REGULATIONS AND STANDARDS.

UNITS REQUIRING APPROVAL DRAWINGS OR MODIFIED ARE NON-RETURNABLE

As drawn As marked

Signed: _____ Date: _____

Printed Name: _____

LEAD TIME WILL START UPON RECEIPT OF SIGNED APPROVAL DRAWING

DISTRIBUTOR'S NAME:		P.O.#
VESTIL MANUFACTURING		X
DRAWN BY: X		W.O.#
DATE: XX/XX/XX		X
REFERENCE: X	SCALE: 1:10	SALES: X
QUOTED LEAD TIME: X	QUOTE #	FILE NAME:
X	X	16-007-271