

GAS POWERED TRAILER MOVER - PTM-GPT

APPROX WEIGHT: 487 lbs.
 DOES NOT INCLUDE WEIGHT OF POWER OR PACKAGING!!!

ANY ADDITIONS, DELETIONS, OR OMISSIONS MUST BE CORRECTED ON THIS DRAWING AS THIS DRAWING WILL BE CONSIDERED ALL INCLUSIVE

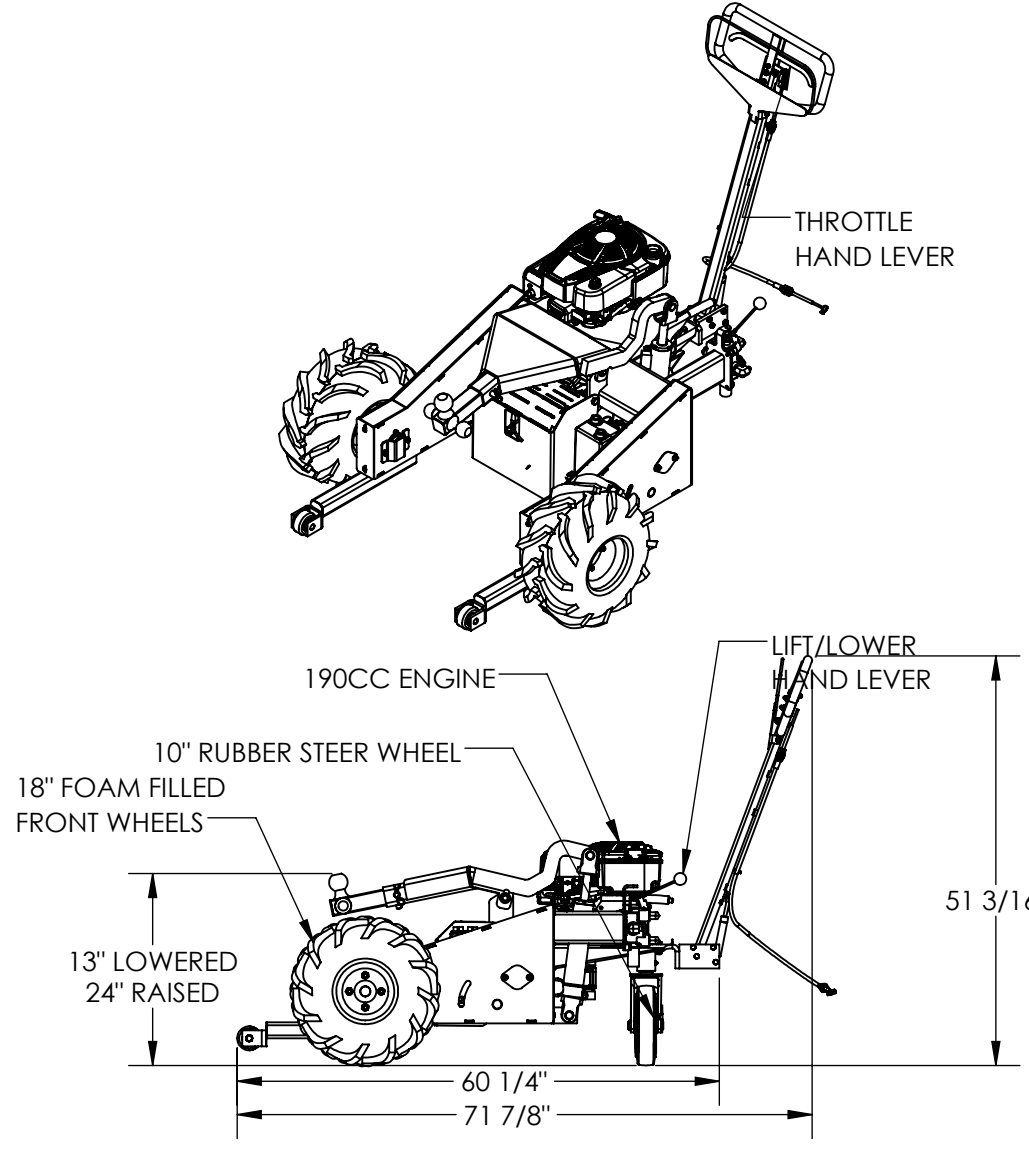
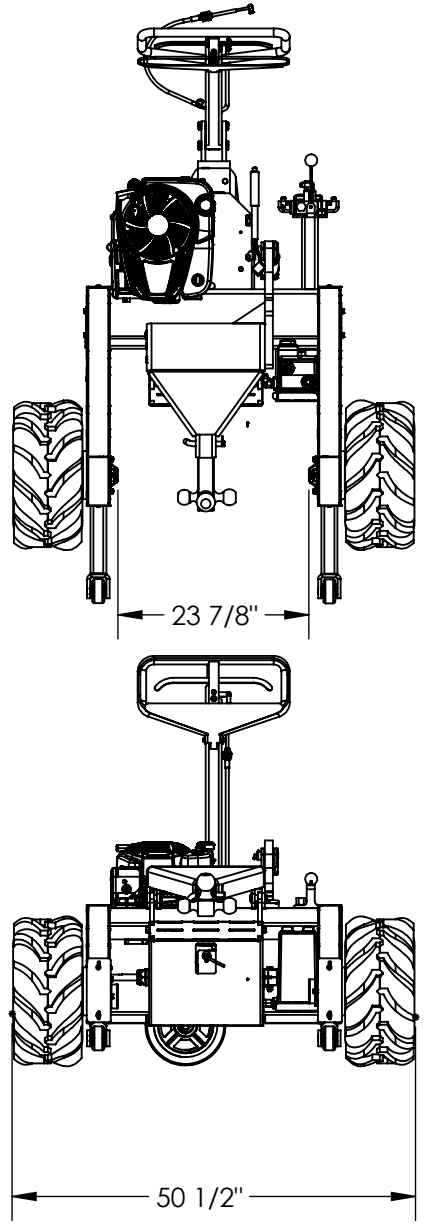

ALL GRAPHICS PROVIDED ARE FOR REFERENCE ONLY. IF CERTAIN DIMENSIONS ARE CRITICAL PLEASE VERIFY THOSE DIMENSIONS WITH YOUR SALESPERSON
 DIMENSION TOLERANCE ± 1/4"

- STANDARD FEATURES**
- MODEL NUMBER IS PTM-GPT
 - LIFTING CAPACITY IS 1,000 LBS
 - PULLING CAPACITY IS 12,000 LBS
 - OVERALL WIDTH IS 50 1/2"
 - OVERALL LENGTH IS 71 7/8"
 - OVERALL HEIGHT IS 51 3/16"
 - SERVICE RANGE IS 13" TO 24"
 - 18" FOAM FILLED FRONT WHEELS
 - 10" RUBBER STEER WHEEL
 - HAND LEVER TO CONTROL LIFT/LOWER
 - SAFETY HANDLE WITH FORWARD/NEUTRAL/REVERSE
 - 190CC BRIGGS AND STRATTON ENGINE
 - COMES WITH 1 7/8", 2", AND 2 5/16" BALL HITCHES
 - DURABLE LIQUID PAINT BLUE FRAME W/ YELLOW HITCH

A P P R O V A L

I, THE UNDERSIGNED, AGREE THAT THE PRODUCT AS REPRESENTED SATISFIES DESIGN AND DIMENSION REQUIREMENTS. I ALSO ACKNOWLEDGE MY DUTY TO CONFIRM PRODUCT AND INSTALLATION COMPLIANCE WITH ALL APPLICABLE FEDERAL, STATE AND LOCAL REGULATIONS AND STANDARDS.

UNITS REQUIRING APPROVAL DRAWINGS OR MODIFIED ARE NON-RETURNABLE

As drawn As marked

Signed: _____ Date: _____

Printed Name: _____

LEAD TIME WILL START UPON RECEIPT OF SIGNED APPROVAL DRAWING

DISTRIBUTOR'S NAME:		P.O.#
VESTIL MANUFACTURING		X
DRAWN BY: KGH		W.O.#
DATE: 12/27/2017		X
REFERENCE: X	SCALE: 1:24	SALES: X
QUOTED LEAD TIME: X	QUOTE # X	FILE NAME:
		50-007-013