



PLUSWINCH™

➤ Assembly & Operation Guide

Contents

Safety Instructions **4**

Safety Regulations
PlusWinch
Load
Wire rope and Hoisting Materials
Technical Details
Function Description
Mounting Instructions
Wire rope Mounting
Correct Operation
Wire Rope Mounting Instructions
Maintenance
Troubleshooting
Service
Environment
Guarantee

Technical Detail **11**

Dimensions **12**

Quality & Safety **13**

Inspection Record **15**

Lightweight. Portable. **Safe.**

Please read the following instructions and guidance notes carefully, before using or operating the system.

They contain important information about how to handle and use the system in a safe and efficient way, avoiding danger, reducing repair costs and downtime, and increasing the reliability and lifespan of the system.

It is the responsibility of the end user to adhere to the Health & Safety and accident prevention standards and legislation valid in their respective countries and any regions in which the system is being used. It is also incumbent on the user or competent person to ensure that anyone working with the equipment has the necessary medical and physical capabilities. A rescue plan also needs to be in place in the event of an emergency that could occur during the work. This document should form part of the overriding Risk Assessment and Method Statement required for each lift.

➤ Safety Instructions

Safety Regulations

The PlusWinch is a hand-driven wire rope winch, fitted with a bracket for mounting to a Reid Lifting Product/structure. The PlusWinch is only to be used for the lifting of goods. The PlusWinch has a static safety factor of 4.

The PlusWinch is not certified to be used as part of a system for rescue purposes

Standing under a moving load is not permitted.

The PlusWinch is not suitable for:

- Continuous use
- Motorized drive
- Explosive Atmospheres

Technical alterations and/or the attachment of additional devices to the PlusWinch is only allowed with the manufacturer's written consent. Servicing, mounting, possible repairs and the maintenance of the PlusWinch are permitted only by specialized persons who:

- Have been appointed and authorized
- Have been trained
- Are familiar with the correct regulations
- Always use original parts for repairs

PlusWinch

The PlusWinch is equipped with a load pressure brake which holds the load at any required height and ensures that it undergoes controlled lowering.

The load pressure brake must not be greased or oiled. This destroys the brake function!

The stipulated hoisting capacity calculated on the first wire rope layer, stated on the type identity sticker must not be exceeded. The PlusWinch must at least be mounted with the required mounting materials from the technical detail tables on page 11. The PlusWinch must be inspected/tested by a professional at least once a year.

Never touch moving parts during use.

Pre-use inspection:

- Ensure the brake functions as intended and holds a load correctly
- Check that the wire rope is in good condition and all parts are present
- Ensure all fixings are present and correctly tightened

Load

Pay attention to the following with respect to the load:

- Never leave the load unattended whilst elevated.
- Do not allow the load to swing.
- Never allow the load to fall suddenly from the wire rope.
- Ensure that the hoisting height remains in clear view.

Wire rope and Hoisting Material(s)

Pay attention to the following with respect to the wire rope and hoisting material(s):

- Only use REID approved wire rope assemblies, all of which are certified to meet BSEN13414-1 European Standard
- The wire rope and load hook must be regularly checked for any damages or defects
- The load must be mounted correctly
- Loading hooks must be fitted with safety catches
- According to the regulations, loading hooks must be mounted to the wire rope with a thimble and a ferrule
- The sideways leverage angle of the wire rope, must not exceed 3 degrees (see Fig. 1)
- There must be a minimum of 3 safety windings on the first layer of the drum when loaded
- The top of the last wire rope layer must have at least one and a half wire rope diameter clearance between the outer edge of the drum flange
- The wire rope must be pre-stressed when being wrapped around the drum
- Never reach into the wire rope assembly
- Only hold the wire rope when wearing safety gloves
- Adhere to the correct wire rope capacity

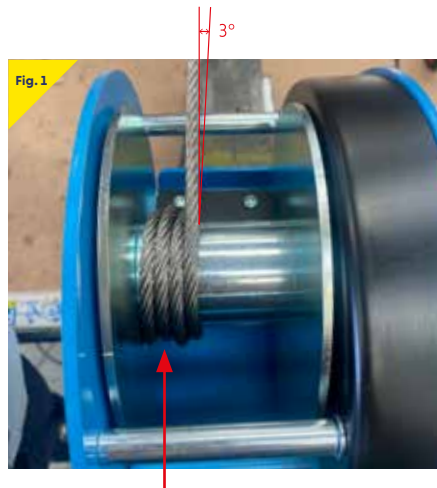

Min. 3 safety windings

➤ Safety Instructions

Technical Details

The code designation is as follows:

Galvanized Steel Wire rope

- US-RLGWG50010
- US-RLGWG50015
- US-RLGWG50020

Spurgear winch with hoisting load of 1100lb

Stainless Steel Wire rope

- US-RLGW000010
- US-RLGW000015
- US-RLGW000020

Spurgear winch with hoisting load of 880lb

Function Description

The PlusWinch is a drum winch with a spur gear transmission. The load is held at each required height by a built-in load pressure brake. The housing is made of plate steel and is suitable for mounting on walls, masts and the like. The handle is adjustable in length and detachable. This version is equipped with wire rope drum free spooling.

Mounting Instructions

The PlusWinch must be mounted with the bolts as set out in the table on page 11.

To avoid tension build up in the PlusWinch housing there must be a smooth surface at the mounting bolt position.

Additional notes for Correct Operation

- The structure must be of a suitable grade and strength for the anchor method
- The level of the mounted PlusWinch must be checked with a spirit level in order to ensure good wire rope movement.

Refer to PlusWinch bracket Assembly & Operation Guide.

Wire Rope Mounting

For PlusWinch with a hoisting load of 1100lb the wire rope must run-off upwards from the right side of the drum.

Warning: The brake will not function if wire rope is incorrectly fitted

The wire rope length must be of sufficient length to allow for 3 windings to remain on the drum when in the lowest position. The wire rope mounting is done by means of the fixed wire rope clamp.

The fixing of the wire rope for the PlusWinch is done directly on the drum by means of a double lock. **See page 7 for full wire rope mounting instructions.**

Correct Operation

The PlusWinch is suitable for manual operation only. For the load to be hoisted, turn the handle clockwise. For the load to be lowered, turn the handle anticlockwise.

To enable the load pressure brake to function correctly, the PlusWinch must carry a minimum load of 155lb.

The PlusWinch is equipped with a Free Spool (FS) option for the wire rope drum. Follow the instructions on page 8 to engage and disengage the wire rope drum.



Wire Rope Mounting Instructions



- 1 > Locate the wire rope clamp on the drum.



- 2 > With the tensioner disengaged using a zip tie, feed the wire rope through the inner clamp location.



- 3 > Wrap the wire rope twice around the drum.



Ensure the wire rope does not pull too far through to ensure the wire rope can wrap over the end without causing damage.

- 4 > Feed the end of the wire rope into the outer clamp location.



- 5 > Secure the wire rope end by tightening the securing bolt.



- 6 > Ensure the wire rope is pulled tightly around the drum and tighten the inner bolt to secure the wire rope as shown.

➤ Safety Instructions

Free Spool Operation

To be able to operate the Free spool clutch handle there must be **no load** on the drum.

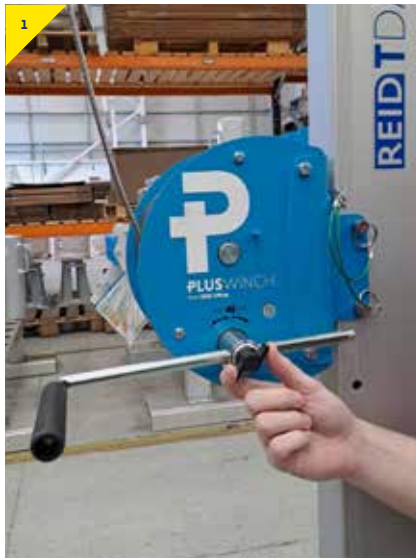

- Loosen the butterfly screw and remove the handle



- Rotate and insert the handle as shown into the free spool mechanism and anchor point.

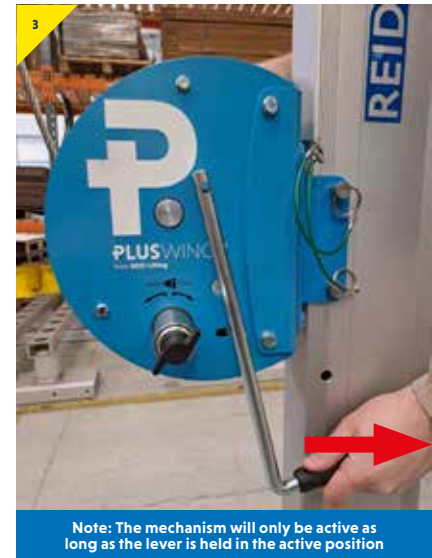

Note: The mechanism will only be active as long as the lever is held in the active position

- Pull the handle as shown to activate the freespool mechanism and unspool as much wire rope as required.

WARNING: Do not activate the free spool system with a load attached.

Maintenance

The PlusWinch must be unloaded for inspection and maintenance tasks. Inspection and maintenance tasks must be performed by skilled personnel.

Inspection/ Maintenance interval	Tasks
Before each use	Visually check wire rope and loading hook
	Check bracket and fixings are all present and correctly tightened
	Check the brake function
Per quarter or operating condition specific (In addition to the previous section)	Visually check wire rope and loading hook for any deformation
Annually (In addition to the previous sections)	Examination complete with report by a Competent Person as safe to use (Legal maximum interval)
	Check the tightness of the mounting bolts
	Check all the winch parts for wear and tear; replace where necessary; grease where needed
	Check the type identity sticker for clarity

> Safety Instructions

Troubleshooting

Trouble/malfunction	Cause	Solution
The unloaded winch is difficult to operate	No grease on the gearing	Apply grease
	Dirt on the gearing	Clean with a detergent and re-grease
	During mounting the winch has pulled askew	Level the mounting surface and re-mount the winch
The load cannot be held	The wire rope has been incorrectly wound round the drum which means the handle turning direction is incorrect	Wind the wire rope correctly around the drum
	The brake discs are either worn down or faulty	Check and/or renew the brake discs
The load pressure brake does not function	Braking mechanism and/or discs are jammed due to infrequent use	Loosen the brake by hitting the handle in the correct turning direction with the flat of the hand

Service

For servicing and/or servicing parts contact your nearest REID representative.

Use original servicing parts only, correct functioning cannot otherwise be guaranteed!

Environment

At the end of the winch's lifespan, the various winch parts must be disposed of according to the current environmental regulations.

Guarantee

Refer to REID lifting guarantee which can be found online at reidlifting.com

Ø ¼" Galvanized Steel Wire Rope			
Wire rope Layer	Wire Rope Capacity per layer	Total Capacity	Max Load (lb)
1	6' 2 ¾"	6' 2 ¾"	1100
2	8' 6 ½"	14' 9 ¼"	1100
3	10' 10"	25' 7"	1100
4	11' 1 ¾"	36' 9"	1050
5	13' 5 ½"	50' 2 ¼"	950
6	13' 5 ½"	63' 7 ¾"	875

Ø ¼" Stainless Steel Wire Rope			
Wire rope Layer	Wire Rope Capacity per layer	Total Capacity	Max Load (lb)
1	6' 2 ¾"	6' 2 ¾"	880
2	8' 6 ½"	14' 9 ¼"	880
3	10' 10"	25' 7"	880
4	11' 1 ¾"	36' 9"	880
5	13' 5 ½"	50' 2 ¼"	880
6	13' 5 ½"	63' 7 ¾"	860

Handle force first layer	34lbf
Transmission ratio	1:7
Hoisting height per handle rev.	½"
Own weight	31lb
Wall fastening, class 8.8 bolts	4 x M10
Permitted environment temperature (°F)	-4/+104
Dimensions	See page 12

Dimensions

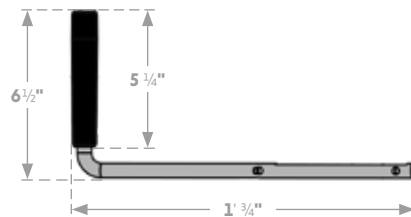
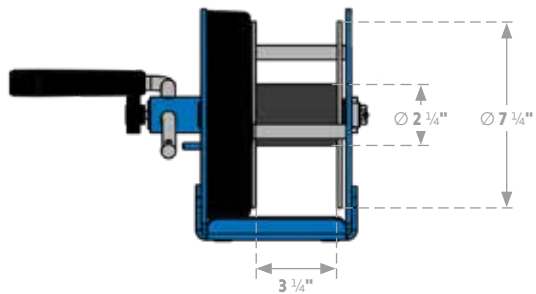
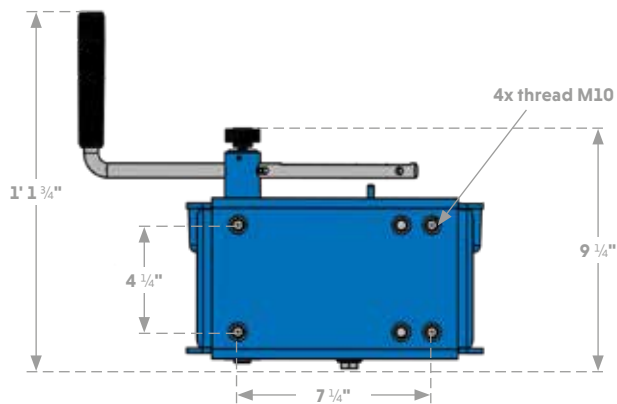
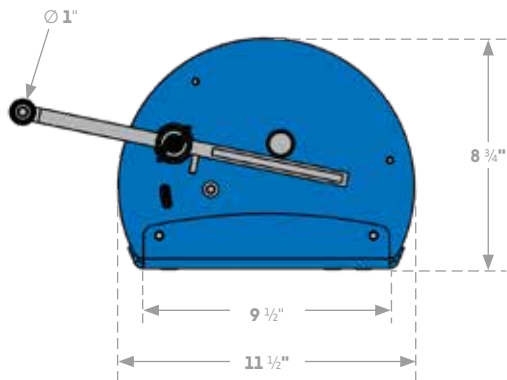

Regulations, Standards & Directives

The PlusWinch is in conformity with the provisions of the Council Directive 2006/42/EC & The Supply of Machinery (Safety) Regulations 2008 and complies with BS EN 13157:2004+A1:2009

It is essential to adhere to the safety regulations of the respective country for using manual lifting equipment.

Accreditations

Quality and safety are key themes throughout this document and the REID Lifting ethos. It is with this in mind that we have undertaken external accreditations to ensure we stay focused on what is important to our clients and users, and ahead of market trends and developments.

REID Lifting is continuously audited by Lloyds Register Quality Assurance (LRQA) for approval of its Integrated Management System combining quality systems management, environmental issues and the health and safety practices within the company.

- ISO 9001:2015 - Specifies requirements for a quality management system for any organization that needs to demonstrate its ability to consistently provide products that meet customer and appliwire rope regulatory requirements and aims to enhance customer satisfaction
- ISO 14001:2015 - Specifies the requirements for implementing environmental management systems throughout all areas of the company
- ISO 45001 – Health & Safety Management System

- LEEA Membership - REID Lifting is a full member of the Lifting Equipment Engineers Association (LEEA membership 000897). REID Lifting conforms to the main aims of the association which is to achieve the highest standards of quality and integrity in the operations of members. Entry qualifications are demanding and strictly enforced through technical audits based on the Technical Requirements for Members

➤ Quality & Safety

Conformité Européenne [CE] & UK Conformity Assessed [UKCA]

REID Lifting's products have been designed, tested and approved (as appropriate) by the Conformité Européenne and UK Conformity Assessed. This certifies that REID Lifting's products meet the demands of the European and UK Directives and Regulations regarding Health and Safety requirements. The EC type-examination for this device has been carried out by SGS United Kingdom Ltd, 202b, Worle Parkway, Weston-super-Mare, BS22 6WA, United Kingdom (CE body no.0120) in accordance with Module B of the PPE Regulation. The EC quality assurance system for this device has been carried out by SGS Fimko Oy, Takomotie 8, FI-00380 Helsinki, Finland. (CE body no. 0598) and SGS United Kingdom Ltd, 202b, Worle Parkway, Weston-super-Mare, BS22 6WA, United Kingdom (CE body no.0120) in accordance with Module D PPE Regulation (EU) 2016/425 and as brought into UK law and amended.

Testing

Testing and technical file review are integral parts of our design and manufacturing process. External verification of products is undertaken where appropriate, using government approved Notified Bodies.

All products have been thoroughly type tested. Each product is supplied with a certificate of conformance and individual record of thorough examination or test.

Language

It is essential for the safety of the user that if this product is re-sold outside of the original country of destination, the reseller shall provide instructions for use, maintenance, inspection and repair in the language of the country where it will be used.

Product IPR

Intellectual property rights apply to all REID Lifting Ltd products. There are patents in place, or pending, for:

PORTAGANTRY™ | **PORTAGANTRY** RAPIDE | **PORTA**DAVIT QUANTUM | **T**DAVIT™

All product names are trademarks of REID Lifting Ltd:

PORTAGANTRY™ | **PORTAGANTRY** RAPIDE | **PORTA**DAVIT™ | **PORTA**BASE | **T**DAVIT™ | **PORTA**QUAD™ | **PORTX**™ | **PLUS**WINCH

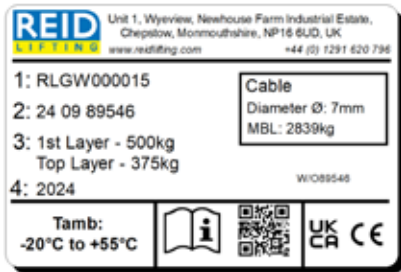

Marking

The serial labels indicate:

- The product identification number
- The product's unique serial number
- The goods' capacity (WLL) of the device
- The year of manufacture
- The standards to which the device is approved
- The ATEX rating of the product (if appliwire rope)
- CE Marking
- Minimum braking load (MBL)

Insert data from serial numbers found on product into table here:

Periodic Examination & Repair History

Date	Inspected by	Pass/Fail	Corrective Action	Comments

Contact Us

REID Lifting Inc, USA

7900 International Drive,
Suite 300,
Bloomington,
MN 55425
USA

- > +1-(888)-721-6411
- > info@reidlifting.com
- > us.reidlifting.com

All information herein is copyright protected by REID Lifting Ltd. All company and product names are Trade Mark and Trade Name protected and all REID Lifting Ltd. Product IPR is protected under Patents, Patents Pending and/or Design Rights.



Printed using environment friendly processes and materials.